

---

# Principles of an Internal Combustion Engine

Course No: M03-046

Credit: 3 PDH

---

Elie Tawil, P.E., LEED AP

---



Continuing Education and Development, Inc.  
22 Stonewall Court  
Woodcliff Lake, NJ 07677

P: (877) 322-5800  
[info@cedengineering.com](mailto:info@cedengineering.com)

---

# Chapter 2

## Principles of an Internal Combustion Engine

### Topics

- 1.0.0 Internal Combustion Engine
- 2.0.0 Engines Classification
- 3.0.0 Engine Measurements and Performance

### Overview

As a Construction Mechanic (CM), you are concerned with conducting various adjustments to vehicles and equipment, repairing and replacing their worn out broken parts, and ensuring that they are serviced properly and inspected regularly. To perform these duties competently, you must fully understand the operation and function of the various components of an internal combustion engine. This makes your job of diagnosing and correcting troubles much easier, which in turn saves time, effort, and money.

This chapter discusses the theory and operation of an internal combustion engine and the various terms associated with them.

### Objectives

When you have completed this chapter, you will be able to do the following:

1. Understand the principles of operation, the different classifications, and the measurements and performance standards of an internal combustion engine.
2. Identify the series of events, as they occur, in a gasoline engine.
3. Identify the series of events, as they occur in a diesel engine.
4. Understand the differences between a four-stroke cycle engine and a two-stroke cycle engine.
5. Recognize the differences in the types, cylinder arrangements, and valve arrangements of internal combustion engines.
6. Identify the terms, engine measurements, and performance standards of an internal combustion engine.

# Prerequisites

None

This course map shows all of the chapters in Construction Mechanic Basic. The suggested training order begins at the bottom and proceeds up. Skill levels increase as you advance on the course map.

Automotive Chassis and Body		C
Brakes		M
Construction Equipment Power Trains		
Drive Lines, Differentials, Drive Axles, and Power Train Accessories		
Automotive Clutches, Transmissions, and Transaxles		
Hydraulic and Pneumatic Systems		
Automotive Electrical Circuits and Wiring		B
Basic Automotive Electricity		A
Cooling and Lubrication Systems		S
Diesel Fuel Systems		I
Gasoline Fuel Systems		C
Construction of an Internal Combustion Engine		
Principles of an Internal Combustion Engine		
Technical Administration		

## Features of this Manual

This manual has several features which make it easy to use online.

- Figure and table numbers in the text are italicized. The figure or table is either next to or below the text that refers to it.
- The first time a glossary term appears in the text, it is bold and italicized. When your cursor crosses over that word or phrase, a popup box displays with the appropriate definition.
- Audio and video clips are included in the text, with italicized instructions telling you where to click to activate it.
- Review questions that apply to a section are listed under the Test Your Knowledge banner at the end of the section. Select the answer you choose. If the answer is correct, you will be taken to the next section heading. If the answer is incorrect, you will be taken to the area in the chapter where the information is for review. When you have completed your review, select anywhere in that area to return to the review question. Try to answer the question again.
- Review questions are included at the end of this chapter. Select the answer you choose. If the answer is correct, you will be taken to the next question. If the answer is incorrect, you will be taken to the area in the chapter where the information is for review. When you have completed your review, select anywhere in that area to return to the review question. Try to answer the question again.

# 1.0.0 INTERNAL COMBUSTION ENGINE

## 1.1.0 Development of Power

The power of an internal combustion engine comes from burning a mixture of fuel and air in a small, enclosed space. When this mixture burns, it expands significantly; building pressure that pushes the piston down, in turn rotating the crankshaft. Eventually this motion is transferred through the transmission and out to the drive wheels to move the vehicle.

Since similar action occurs in each cylinder of an engine, let's use one cylinder to describe the steps in the development of power. The four basic parts of a one-cylinder engine is: the cylinder, piston, connection rod, and the crankshaft, as shown in *Figure 2-1*.

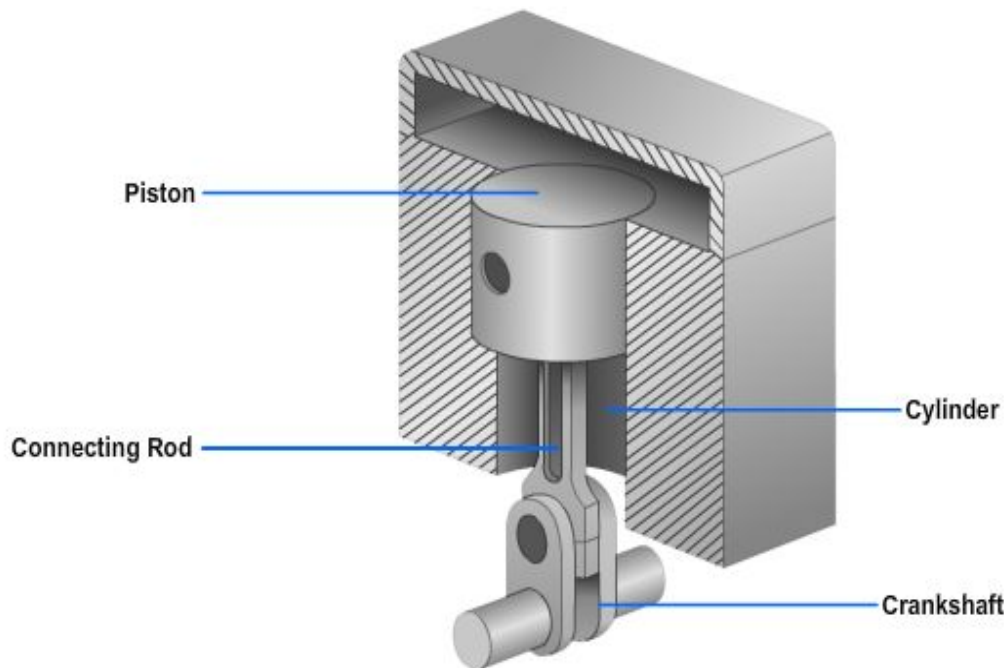

**Figure 2-1 – Cylinder, piston, connecting rod, and crankshaft for a one-cylinder engine.**

First, there must be a cylinder that is closed at one end; this cylinder is similar to a tall metal can that is stationary within the engine block.

Inside this cylinder is the piston—a movable plug. It fits snugly into the cylinder but can still slide up and down easily. This piston movement is caused by fuel burning in the cylinder and results in the up-and-down movement of the piston (reciprocating) motion.

This motion is changed into rotary motion by the use of a connecting rod that attaches the piston to the crankshaft throw.

The throw is an offset section of the crankshaft that scribes a circle as the shaft rotates. Since the top of the connecting rod is attached to the piston, it must travel up and down. The bottom of the connecting rod is attached to the throw of the crankshaft; as it travels up and down, it also is moved in a circle. So remember, the crankshaft and connecting rod combination is a mechanism for the purpose of changing straight line, or reciprocating motion to circular, or rotary motion.

## 1.2.0 Four-Stroke-Cycle Engine

Each movement of the piston from top to bottom or from bottom to top is called a stroke. The piston takes two strokes (an up stroke and a down stroke) as the crankshaft makes one complete revolution. *Figure 2-2* shows the motion of a piston in its cylinder.

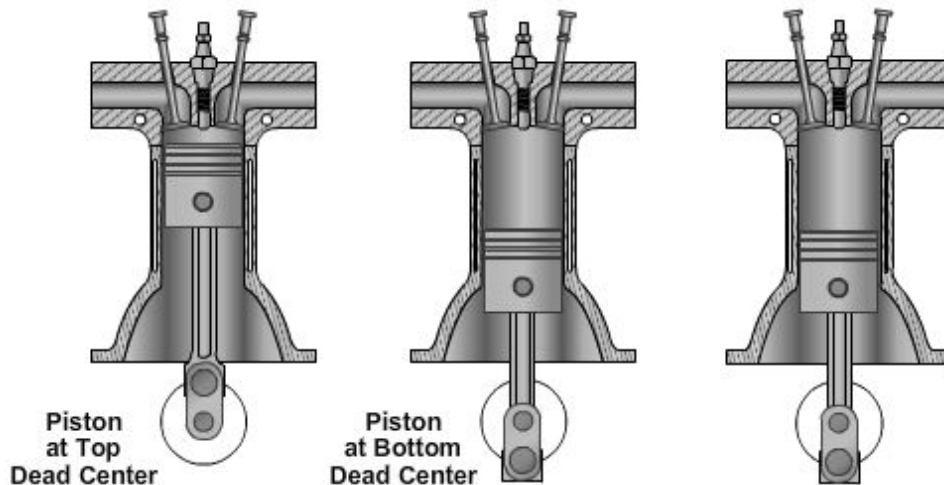

**Figure 2-2 – Piston stroke technology.**

The piston is connected to the rotating crankshaft by a connecting rod. In *View A*, the piston is at the beginning or top of the stroke. When the combustion of fuel occurs, it forces the piston down, rotating the crankshaft one half turn. Now look at *View B*. As the crankshaft continues to rotate, the connecting rod begins to push the piston up. The position of the piston at the instant its motion changes from down to up is known as bottom dead center (BDC). The piston continues moving upward until the motion of the crankshaft causes it to begin moving down. This position of the piston at the instant its motion changes from up to down is known as top dead center (TDC). The term *dead* indicates where one motion has stopped (the piston has reached the end of the stroke) and its opposite turning motion is ready to start. These positions are called rock positions and discussed later under "Timing."

The following paragraphs provide a simplified explanation of the action within the cylinder of a four-stroke-cycle gasoline engine. It is referred to as a four-stroke-cycle because it requires four complete strokes of the piston to complete one engine cycle. Later a two-stroke-cycle engine is discussed. The action of a four-stroke-cycle engine may be divided into four parts: the intake stroke, the compression stroke, the power stroke, and the exhaust stroke.

### 1.2.1 Intake Stroke

The intake stroke draws the air-fuel mixture into the cylinder. During this stroke, the piston is moving downward and the intake valve is open. This downward movement of the piston produces a partial vacuum in the cylinder, and the air-fuel mixture rushes into the cylinder past the open intake valve.

### 1.2.2 Compression Stroke

The compression stroke begins when the piston is at bottom dead center. As the piston moves upwards, it compresses the fuel and air mixture. Since both the intake and exhaust valves are closed, the fuel and air mixture cannot escape. It is compressed to a fraction of its original volume.

### 1.2.3 Power Stroke

The power stroke begins when the piston is at top dead center (TDC). The engine ignition system consists of spark plugs that emit an electrical arc at the tip to ignite the fuel and air mixture. When ignited, the burning gases expand, forcing the piston down. The valves remain closed so that all the force is exerted on the piston.

### 1.2.4 Exhaust Stroke

After the air-fuel mixture has burned, it must be cleared from the cylinder. This is done by opening the exhaust valve just as the power stroke is finished, and the piston starts back up on the exhaust stroke. The piston forces the burned gases out of the cylinder past the open exhaust valve. *Figure 2-3* shows the operations of a four-stroke-cycle gasoline engine.

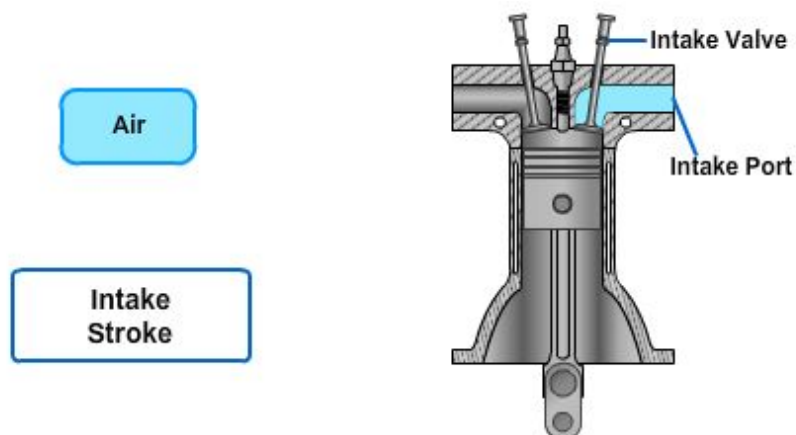
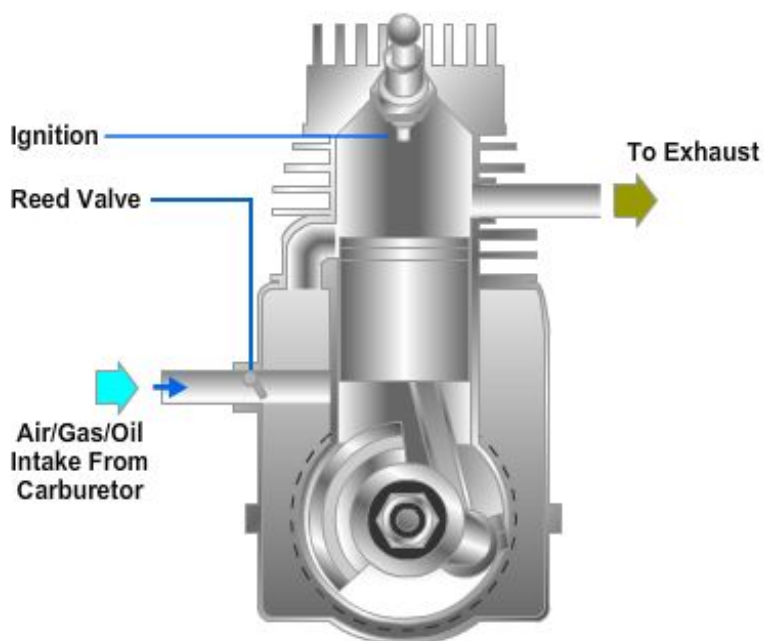

**Figure 2-3 – Four-stroke cycle gasoline engine in operation.**

### 1.3.0 Two-Stroke-Cycle Engine

*Figure 2-4* depicts the two-stroke-cycle engine. The same four events (intake, compression, power, and exhaust) take place in only two strokes of the piston and one complete revolution of the crankshaft. The two piston strokes are the compression stroke (upward stroke of the piston) and power stroke (the downward stroke of the piston).

As shown, a power stroke is produced every crankshaft revolution within the two-stroke-cycle engine, whereas the four-stroke-cycle engine requires two revolutions for one power stroke.



**Compression Action Of A Two-Stroke Engine**

**Figure 2-4 — Two-stroke-cycle engine.**

## **2.0.0 ENGINES CLASSIFICATION**

Engines for automotive and construction equipment may be classified in a number of ways: type of fuel used, type of cooling used, or valve and cylinder arrangement. They all operate on the internal combustion principle, and the application of basic principles of construction to particular needs or systems of manufacture has caused certain designs to be recognized as conventional.

The most common method of classification is by the type of fuel used, that is, whether the engine burns gasoline or diesel fuel.

### **2.1.0 Diesel Engine**

Diesel engines can be classified by the number of cylinders they contain. Most often, single cylinder engines are used for portable power supplies. For commercial use, four, six and eight cylinder engines are common. For industrial use such as locomotives and marine use, twelve, sixteen, twenty and twenty-four cylinder arrangements are seen.

#### **2.1.1 Engine Cycle Design**

The four-stroke cycle diesel engine is similar to the four-stroke gasoline engine. It has the same operating cycle consisting of an intake, compression, power, and exhaust stroke. Its intake and exhaust valves also operate in the same manner. The four-stroke cycle of a diesel engine is as follows:

- Diesel Engine Intake Stroke – The intake stroke begins when the piston is at top dead center. As the piston moves down, the intake valve opens. The downward movement of the piston draws air into the cylinder. As the piston reaches bottom dead center, the intake valve closes.
- Diesel Engine Compression Stroke – The compression stroke begins when the piston is at bottom dead center. As the piston moves upwards, the air is compressed to as much as 500 pounds per square inch (psi) at a temperature approximately 1000°F.
- Diesel Engine Power Stroke – The power stroke begins when the piston is at top dead center. The engine's fuel injection system delivers fuel into the combustion chamber. The fuel is ignited by the heat of the compression. The expanding force of the burning gases pushes the piston downwards, providing power to the crankshaft. The diesel fuel will continue to burn through the entire power stroke (a more complete burning of fuel). The gasoline engine has a power stroke with rapid combustion in the beginning, but little to no combustion at the end.
- Diesel Engine Exhaust Stroke – The exhaust stroke begins with the piston at bottom dead center. As the piston move upwards, the exhaust valve opens. The burnt gases are pushed out through the exhaust port. As the piston reaches top dead center, the exhaust valve closes and the intake valve opens. The engine is now ready to begin the next cycle.



### 2.1.2 Cylinder Arrangement

*Figure 2-5* shows the most common types of engine designs. The inline cylinder arrangement is the most common design for a diesel engine. They are less expensive to overhaul, and accessory items are easier to reach for maintenance. The cylinders are lined up in a single row. Typically there are one to six cylinders and they are arranged in a straight line on top of the crankshaft. In addition to conventional vertical mounting, an inline engine can be mounted on its side. This is common in buses when the engine is under the rear seating compartment. When the cylinder banks have an equal number on each side of the crankshaft, at 180 degrees to each other, it is known as a horizontally-opposed engine.

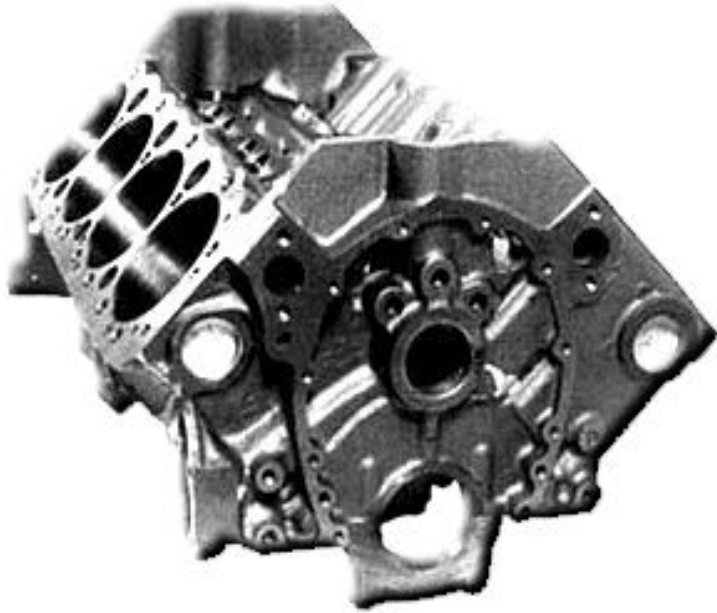

"V" Type Engine Block

**Figure 2-5 — Engine block designs.**

V-type engines are another popular engine configuration. Cylinders are set up on two banks at different angles from the crankshaft, as shown in *Figure 2-5*. A V-type engine looks like the letter V from the front view of the engine. Typical angles are 45, 50, 55, 60 and 90 degrees. The angle is dependent on the number of cylinders and design of the crankshaft. The typical V-type engines are available in six through twenty-four cylinders; however, other configurations are available.

The W-type engine design is like two V-type engines made together and operating a single crankshaft. These engines are used primarily in marine applications, as shown in *Figure 2-5*.

### 2.1.3 Combustion Chamber Design

In order to have the best power with low emissions, you need to achieve complete fuel combustion. The shape of the combustion chamber combined with the action of the piston was engineered to meet that standard. *Figure 2-6* shows the direct injection, precombustion and swirl chamber designs.

Direct injection is the most common and is found in nearly all engines. The fuel is injected directly into an open combustion chamber formed by the piston and cylinder head. The main advantage of this type of injection is that it is simple and has high fuel efficiency.

In the direct combustion chamber, the fuel must atomize, heat, vaporize and mix with the combustion air in a very short period of time. The shape of the piston helps with this during the intake stroke. Direct injection systems operate at very high pressures of up to 30,000 psi.

Indirect injection chambers were used mostly in passenger cars and light truck applications. They were used previously because of lower exhaust emissions and quietness. In today's technology with electronic timing, direct injection systems are superior. Therefore, you will not see many indirect injections system on new engines. They are, however, still on many older engines.

Precombustion chamber design involves a separate combustion chamber located in either the cylinder head or wall. As *Figure 2-6* shows, this chamber takes up from 20% - 40% of the combustion chambers TDC volume and is connected to the chamber by one or more passages. As the compression stroke occurs, the air is forced up into the precombustion chamber. When fuel is injected into the precombustion chamber, it partially burns, building up pressure. This pressure forces the mixture back into the combustion chamber, and complete combustion occurs.

Swirl chamber systems use the auxiliary combustion chamber that is ball-shaped and opens at an angle to the main combustion chamber. The swirl chamber contains 50% - 70% of the TDC cylinder volume and is connected at a right angle to the main combustion chamber. A strong vortex (mass of swirling air) is created during the compression stroke. The injector nozzle is positioned so the injected fuel penetrates the vortex, strikes the hot wall, and combustion begins. As combustion begins, the flow travels into the main combustion chamber for complete combustion.

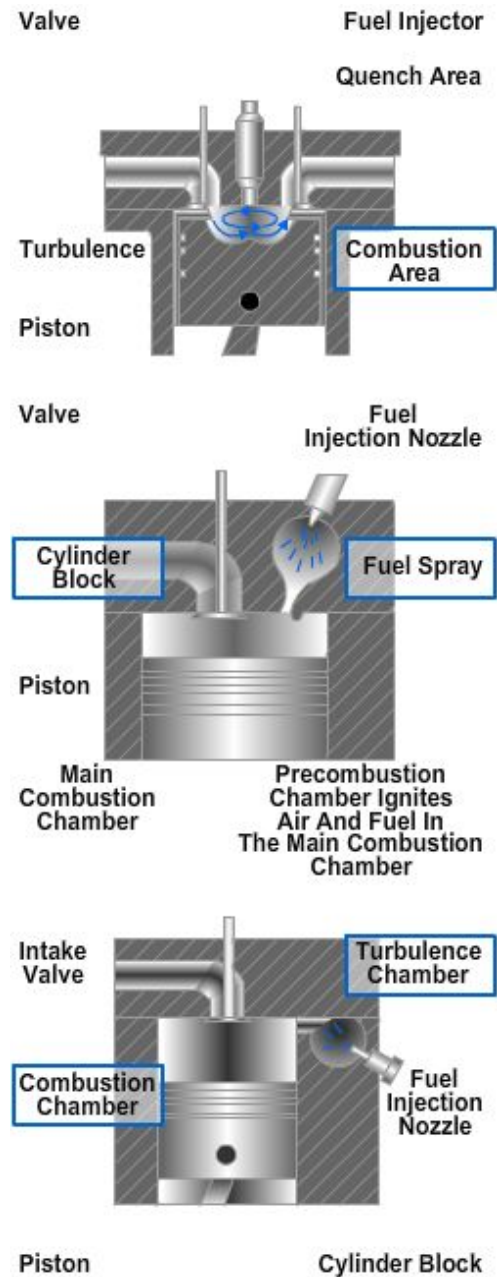

**Figure 2-6 — Direct and indirect injection.**

Energy cells are used with pintle type injectors. As shown in *Figure 2-7*, the system consists of two separate chambers connected with a passageway. As injection occurs, a portion of the fuel passes through the combustion chamber to the energy cell. The atomized portion of the fuel starts to burn. Due to the size and shape of the cell, the flame is forced back into the main combustion chamber, forcing the complete ignition. Because of the smooth flow and steady combustion rate, the engine runs smooth and the fuel efficiency is excellent.

### 2.1.4 Fuel Injection System Design

The heart of the diesel engine is the injection system. It needs to be designed to provide the exact same amount to each cylinder so the engine runs smooth, and it needs to be timed correctly so peak power can be achieved. If it is delivered too early, the temperature will be down, resulting in incomplete combustion. If it is too late, there will be too much room in the combustion chamber and there will be a loss of power. The system also needs to be able to provide a sufficient pressure to the injector; in some cases as much as 5,000 psi is needed to force the fuel into the combustion chamber. A governor is needed to regulate the amount of fuel fed to the cylinders. It provides enough pressure to keep the engine idling without stalling, and cuts off when the maximum rated speed is achieved. The governor is in place to help from destroying the engine because of the fuel pressure available.

There are six different types of fuel injection systems: individual pump systems; multiple-plunger, inline pump systems; unit injector systems; pressure-time injection systems; distributor pump systems, and common rail injection systems.

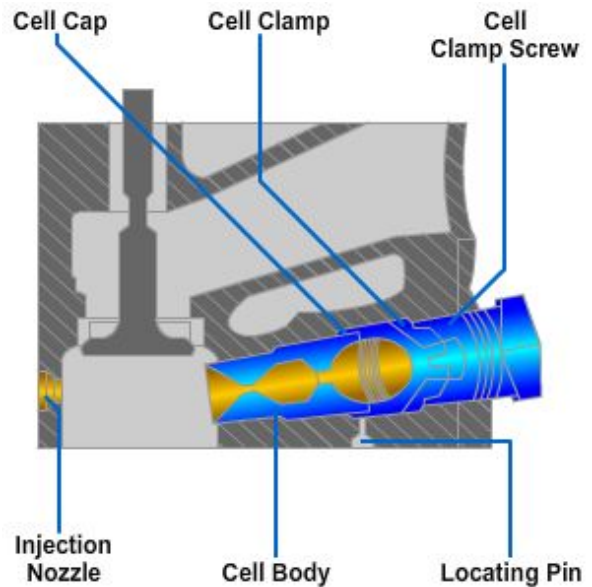

**Figure 2-7 – Energy cells.**

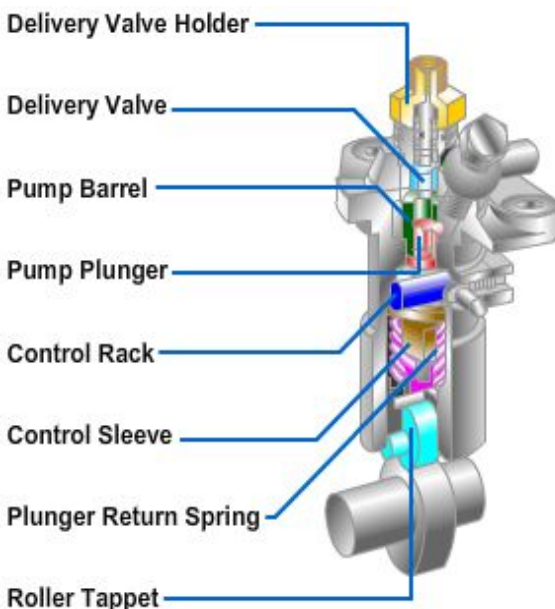

**Figure 2-8 – Individual pump system.**

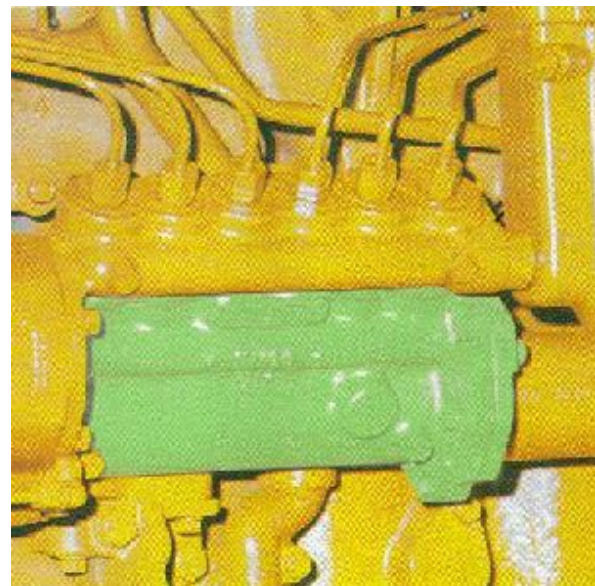

**Figure 2-9 – Multiple-plunger, inline pump system.**

- The individual pump system is a small pump contained in its own housing, and supplies fuel to one cylinder. The individual plunger and pump barrel, shown in *Figure 2-8*, are driven off of the engine's cam shaft. This system is found on large-bore, slow speed industrial or marine diesel engines and on small air-cooled diesels; they are not used on high speed diesels.
- Multiple-plunger, inline pump systems, shown in *Figure 2-9*, use individual pumps that are contained in a single injection pump housing. The number of plungers is equal the number of cylinders on the engine and they are operated on a pump camshaft. This system is used on many mobile applications and is very popular with several engine manufacturers.

The fuel is drawn in from the fuel tank by a pump, sent through filters, and then delivered to the injection pump at a pressure of 10 to 35 psi. All pumps in the housing are subject to this fuel. The fuel at each pump is timed, metered, pressurized, and delivered through a high-pressure fuel line to each injector nozzle in firing order sequence.

- Unit injector systems utilize a system that allows timing, atomization, metering, and fuel pressure generation that takes place inside the injector body and services a particular cylinder. This system is compact and delivers a fuel pressure that is higher than any other system today.

Fuel is drawn from the tank by a transfer pump, is filtered and then delivered. The pressure is 50 – 70 psi before it enters the fuel inlet manifold located within the engine's cylinder head. All of the injectors are fed through a fuel inlet or jumper line. The fuel is pressurized, metered, and timed for proper injection to the combustion chamber by the injector. This system uses a camshaft-operated rocker arm assembly or a pushrod-actuated assembly to operate the injector plunger.

- Pressure-time injection system (PT system) got its name from two of the primary factors that affect the amount of fuel injected per combustion cycle. Pressure or "P" refers to the pressure of the fuel at the inlet of the injector. Time or "T" is the time available for the fuel to flow into the injector cup. The time is controlled by how fast the engine is rotating.

The PT system uses a camshaft-actuated plunger, which changes the rotary motion of the camshaft to a reciprocating motion of the injector. The movement opens and closes the injector metering orifice in the injector barrel. Fuel will only flow when the orifice is open; the metering time is inversely proportional to engine speed. The faster the engine is operating, the less time there is for fuel to enter. The orifice opening size is set according to careful calibration of the entire set of injection nozzles.

- Distributor pump systems are used on small to medium-size diesel engines. These systems lack the capability to deliver high volume fuel flow to heavy-duty, large displacement, high speed diesel engines like those used in trucks. These systems are sometimes called rotary pump systems. Their operating systems are similar to how an ignition distributor operates on a gasoline engine. The rotor is located inside the pump and distributes fuel at a high pressure to individual injectors at the proper firing order.

- Common rail injection systems are the newest high-pressure direct injection system available for passenger car and light truck applications. This system uses an advanced design fuel pump that supplies fuel to a common rail and then delivers it to the injectors by a short high-pressure fuel line. This system utilizes an electronic control unit that precisely controls the rail pressure, timing, and duration of the fuel. The injector nozzles are operated by rapid-fire solenoid valves or piezo-electric triggered actuators. This is the only system designed to be operated by an electronically-controlled fuel injection system. This is necessary to meet modern performance, fuel efficiency, and emission standards. Of all of the systems available today, the common rail injection system has emerged as the predominant choice for diesel engines today.

## 2.2.0 Gasoline Engine

### 2.2.1 Operational Cycles

In the four-stroke cycle gasoline engine, there are four strokes of the piston in each cycle: two up and two down. The four strokes of a cycle are intake, compression, power, and exhaust. A cycle occurs during two revolutions of the crankshaft.

- Intake Stroke – The intake stroke begins when the piston is at top dead center. As the piston moves downwards, the intake valve opens. The downward movement of the piston creates a vacuum in the cylinder, causing the fuel and air mixture to be drawn through the intake port and into the combustion chamber. As the piston reaches bottom dead center, the intake valve closes.
- Compression Stroke – The compression stroke begins when the piston is at bottom dead center. As the piston moves up upwards, it compresses the fuel and air mixture. Since both the intake and exhaust valves are closed, the fuel and air mixture cannot escape. It is compressed to a fraction of its original volume.
- Power Stroke – The power stroke begins when the piston is at top dead center. The engine ignition system consists of spark plugs that emit an electrical arc at the tip to ignite the fuel and air mixture. When ignited, the burning gases expand, forcing the piston down. The valves remain closed so that all the force is exerted on the piston.
- Exhaust Stroke – The exhaust stroke begins when the piston nears the end of the power stroke and the exhaust valve opens. As the piston moves upwards, it pushes the burnt gases out of the combustion chamber through the exhaust port. After the piston reaches top dead center, the exhaust valve closes. The next cycle begins when the intake valve opens. *Figure 2-10* shows the operations of a four-stroke cycle gasoline engine.

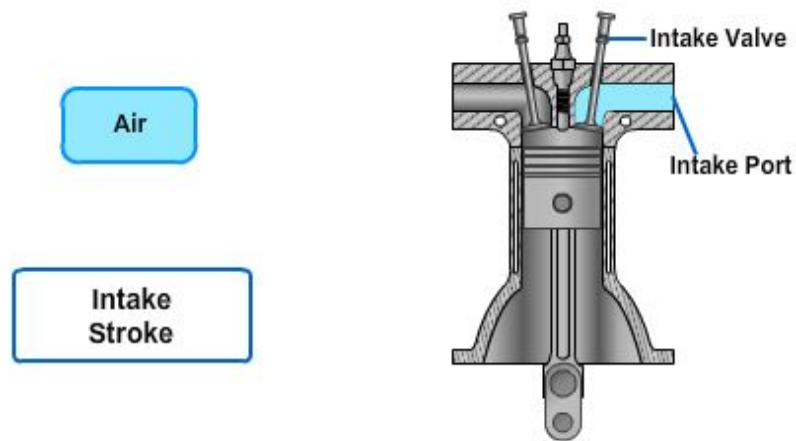

**Figure 2-10 – Four-stroke cycle gasoline engine in operation.**

### 2.2.2 Number of Cylinders

Engines come with a variety of cylinder configurations. Typically in automotive settings, engines have either four, six or eight cylinders. A few may have three, five, ten, twelve or sixteen. Usually the greater the number of cylinders an engine has, the greater the horsepower is generated with an increase of smoothness of engine. Generally a four or five cylinder engine is an inline design while a six cylinder can have an inline or V –type. Eight, ten or twelve are usually a V-type design.

### 2.2.3 Cylinder Arrangement

The position of the cylinders in relation to the crankshaft determines the cylinder arrangement. *Figure 2-11* depicts the five basic arrangements:

In an inline engine the cylinders are lined up in a single row. Typically there are one to six cylinders arranged in a straight line on top of the crankshaft.

A V-type engine looks like the letter V from the front view of the engine. There are two banks of cylinders at an angle to each other on top of the crankshaft. The benefit of this design is a shorter and lighter engine block.

A slant engine is similar to an inline except the bank of cylinders is off to an angle over the crankshaft. This is done to save space in the engine compartment.

The W-shaped engine looks like the letter W from the front view of the engine. Two banks of cylinders form the V shape, except the cylinders are slightly offset, forming a very narrow V. This allows the manufacturer to make an engine with a bigger displacement without making a bigger engine block.

The opposed cylinder engine lies flat on its side with the crankshaft between the cylinder banks; because of the way the engine looks, it is sometimes referred to as a pancake engine.

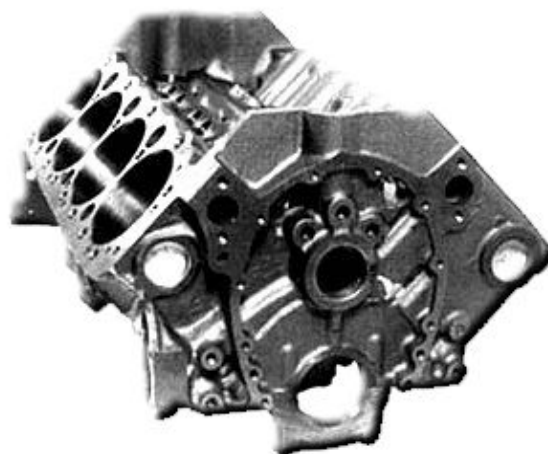

"V" Type Engine Block

**Figure 2-11 – Cylinder arrangements.**

## 2.2.4 Valve Train Type

The valve train consists of the valves, camshaft, lifters, push rods, rocker arms and valve spring assemblies as shown in *Figure 2-12*.

The purpose is to open and close the valves at the correct time to allow gases into or out of the combustion chamber, as shown in *Figure 2-12*. As the camshaft rotates, the lobes push the push rods that open and close the valves.

The camshaft is connected to the crankshaft by belt, chain or gears. As the crankshaft rotates, it also rotates the camshaft. There are three common locations of the camshaft that determine the type of valve train the engine has. These are shown in *Figure 2-13*: the valve in block or L head, the cam in block (also called the I head or overhead valve), and the overhead cam.

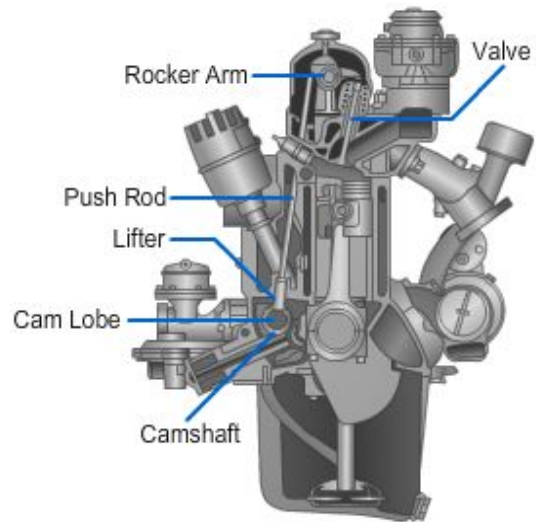

**Figure 2-12 – Valve train parts.**

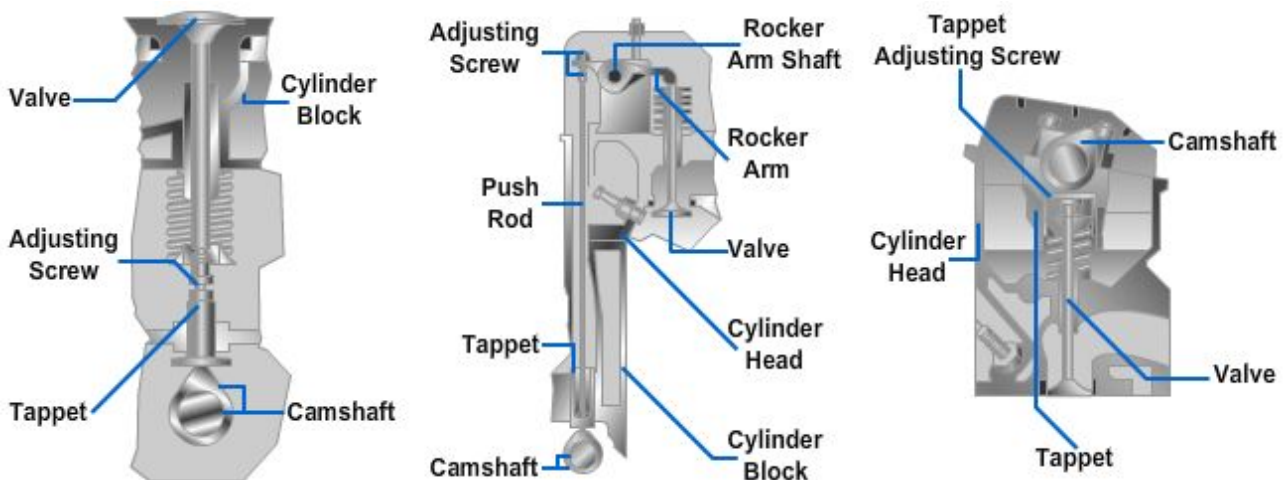

**Figure 2-13 – Valve train type.**

## 2.2.5 Cooling System

The cooling system has many functions. It must remove heat from the engine, maintain a constant operating temperature, increase the temperature of a cold engine and provide a source of heat for the passengers inside the automobile. Without a cooling system, the engine could face catastrophic failure in only a matter of minutes.

There are two types of cooling systems: liquid, the most common, and air. Although both systems have the same goal, to prevent engine damage and wear caused by heat from moving engine parts (friction) the liquid system is the most common.

The air cooling system uses large cooling fins located around the cylinder on the outside. These fins are engineered to use the outside air to draw the heat away from the cylinder. The system typically uses a shroud (enclosure) to route the air over the cylinder fins. Thermostatically-controlled flaps open and close the shroud to regulate air flow and therefore control engine temperature.

There are two types of liquid cooling systems; open and closed.

The closed cooling system has an expansion tank or reservoir, and a radiator cap with pressure and vacuum valves. There is an overflow tube that connects the radiator and the reservoir tank. The pressure and vacuum valve in the radiator cap pushes or pulls coolant into the reservoir tank instead of leaking out onto the ground. As the temperature rises, the fluid is pressurized causing the fluid to transfer to the reservoir tank. When the engine is shut off, the temperature decreases, causing a vacuum and moving the coolant to the radiator.

The open system does not use a coolant reservoir. There is simply an overflow hose attached to the radiator; when the coolant heats up and expands, the coolant overflows the radiator and out onto the ground. This system is no longer used; it has been replaced with the closed system because it is safer for the environment and easier to maintain.

The liquid cooling system, as shown in *Figure 2-14*, is comprised of several components which make it a system. The most common are the water pump, radiator, radiator hoses, fan, and thermostat.

- The water pump does just what the name says—it moves water/coolant through the engine to the radiator. It is often driven by a belt, but in some cases it can be gear-driven.
- The radiator transfers the heat from the coolant inside it to the outside air, and is normally mounted in front of the engine. The radiator core is made up of tubes and cooling fins. As the air moves over these fins, the heat is transferred to the outside air, thereby lowering the temperature of the coolant.
- Radiator hoses are a means to transfer the coolant from the engine to and from radiator. The upper hose usually connects the radiator to the engine via the thermostat housing. The lower hose usually connects the radiator to the water pump inlet housing.
- The cooling system fan pulls air across the fins in the radiator to transfer the heat from the coolant. Its main function is to prevent overheating when the vehicle is not moving or not moving very fast and the air transfer across the radiator is decreased. There are two basic types of fans, engine-powered and electric-powered. The engine-powered fan is run off a drive belt from the crankshaft pulley. There are also three types of engine-powered fans. A flex fan has thin flexible blades. As the engine is at idle, requiring more air, the blades are curved and draw a lot of air; however, as the engine speeds up, the blades flex until they are almost straight, drawing little air but at the same time reducing used engine power.

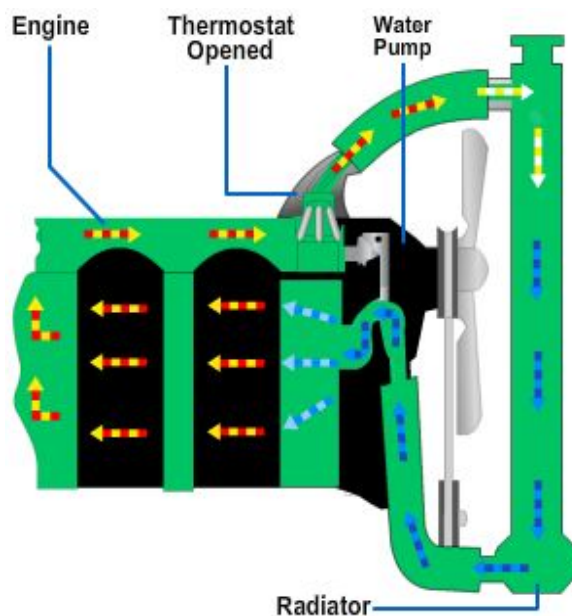

**Figure 2-14– Closed cooling system.**



is not able to keep up and allows the blade to slip. This allows for a reduction of engine power consumed.

The thermostatic fan clutch has a temperature sensitive metal spring that controls the fan speed. The spring controls oil flow in the fan clutch. When the spring is cold, it allows the clutch to slip. As the spring heats up, the clutch locks and forces air circulation.

The thermostat senses the temperature of the engine and opens or closes to control water flow as required. The thermostat has a wax-filled pellet contained in a cylinder. A spring holds the piston and valve in a normally closed position. As the temperature increases, the wax heats up and expands, allowing the valve to open. As the temperature decreases, the wax cools, retracts, and closes the valve.

### **2.2.6 Fuel Type**

An engine burns fuel as a source of energy. Various types of fuel will burn in an engine: gasoline, diesel fuel, gasohol, alcohol, liquefied petroleum gas, and other alternative fuels.

Gasoline is the most common type of automotive fuel. It is abundant and highly flammable. Extra chemicals like detergents and antioxidants are mixed into it to improve its operating characteristics. Antiknock additives are introduced to slow down the burning of gasoline. This helps prevent engine ping, or the knocking sound produced by abnormal, rapid combustion.

Gasoline has different octane ratings. This is a measurement of the fuel's ability to resist knock or ping. A high octane rating indicates that fuel will not knock or ping easily. High-octane gasoline should be used in high-compression engines. Low-octane gasoline is more suitable for low-compression engines.

Diesel fuel is the second most popular type of automotive fuel. A single gallon of diesel fuel contains more heat energy than a gallon of gasoline. It is a thicker fraction or part of crude oil. Diesel fuel can produce more cylinder pressure and vehicle movement than an equal part of gasoline.

Since diesel fuel is thicker and has different burning characteristics than gasoline, a high-pressure injection system must be utilized. Diesel fuel will not vaporize as easily as gasoline. Diesel engines require the fuel to be delivered directly into the combustion chamber.

Diesel fuel has different grades as well: No. 1, No. 2, and No. 4 diesel. No. 2 is normally recommended for use in automotive engines. It has a medium viscosity (thickness or weight) grade that provides proper operating traits for the widest range of conditions. It is also the only grade of diesel fuel at many service stations.

No. 1 diesel is a thinner fuel. It is sometimes recommended as a winter fuel for the engines that normally use No. 2. No. 1 diesel will not provide the adequate lubrication for engine consumption.

One of the substances found in diesel fuel is paraffin or wax. At very cold temperatures, this wax can separate from the other parts of diesel fuel. When this happens the fuel will appear cloudy or milky. When it reaches this point it can clog fuel filters and prevent diesel engine operation.

Water contamination is a common problem with diesel fuel. Besides clogging filters, it also can cause corrosion within the system, and just the water alone can cause damage to the fuel pumps and nozzles.

Diesel fuel has a cetane rating instead of an octane rating like gasoline. A cetane rating indicates the cold starting ability of diesel fuel. The higher the rating, the easier the engine will start and run in cold weather. Most automakers recommend a rating of 45, which is the average value for No. 2 diesel fuel.

Alternative fuels include any fuel other than gasoline and diesel fuel. Liquefied petroleum gas, alcohol, and hydrogen are examples of alternative fuels.

Liquefied petroleum gas (LPG) is sometimes used as a fuel for automobiles and trucks. It is one of the lightest fractions of crude oil. The chemical makeup of LPG is similar to that of gasoline. At room temperature, LPG is a vapor, not a liquid. A special fuel system is needed to meter the gaseous LPG into the engine. LPG is commonly used in industrial equipment like forklifts; it is also used in some vehicles like automobiles and light trucks. LPG burns cleaner and produces fewer exhaust emissions than gasoline.

Alcohol has the potential to be an excellent alternative fuel for automobile engines. The two types of alcohol used are ethyl alcohol and methyl alcohol.

Ethyl alcohol, also called grain alcohol or ethanol, is made from farm crops. Grain, wheat, sugarcane, potatoes, fruits, oats, soy beans, and other crops rich in carbohydrates can be made into ethyl alcohol.

Methyl alcohol, also called wood alcohol or methanol, can be made out of wood chips, petroleum, garbage, and animal manure.

Alcohol is a clean-burning fuel for automobile engines. It is not common because it is expensive to produce and a vehicle's fuel system requires modification to burn it. An alcohol fuel system requires twice the amount burned as gasoline, therefore cutting the economy in half.

Gasohol is a mixture of gasoline and alcohol. It generally is 87 octane gasoline and grain alcohol; the mixture can be from 2-20% alcohol. It is commonly used as an alternative fuel in automobiles because there is no need for engine modifications. The alcohol tends to reduce the knocking tendencies of gasoline; it acts like an anti-knock additive. A 10% alcohol volume can increase 87 octane gasoline to 91 octane. Gasohol can be burned in high-compression engines without detonating and knocking.

Synthetic fuels are fuels made from coal, shale oil rock, and tar sand. These fuels are synthesized or changed from solid hydrocarbons to a liquid or gaseous state. Synthetic fuels are being experimented with as a means of supplementing crude oil because of the price and availability of these fuels.

Hydrogen is a highly flammable gas that is a promising alternative fuel for the future, and it is one of the most abundant elements on the planet. It can be produced through the electrolysis of water. It burns almost perfectly, leaving only water and harmless carbon dioxide as a by-product.

### **3.0.0 ENGINE MEASUREMENTS and PERFORMANCE**

As a CM, you must know the various ways that engines and engine performance are measured. An engine may be measured in terms of cylinder diameter, piston stroke, and number of cylinders. Its performance may be measured by the torque and horsepower it develops, and by efficiency.

## 3.1.0 Definitions

### 3.1.1 Work

Work is the movement of a body against an opposing force. In the mechanical sense of the term, this occurs when resistance is overcome by a force acting through a measured distance. Work is measured in units of foot-pounds. One foot-pound of work is equivalent to lifting a 1-pound weight a distance of 1 foot. Work is always the force exerted over a distance. When there is no movement of an object, there is no work, regardless of how much force is exerted.

### 3.1.2 Energy

Energy is the ability to do work. Energy takes many forms, such as heat, light, sound, stored energy (potential), or as an object in motion (kinetic energy). Energy performs work by changing from one form to another. Take the operation of an automobile for example; it does the following:

- When a car is sitting still and not running, it has potential energy stored in the gasoline.
- When a car is set in motion, the gasoline is burned, changing its potential energy into heat energy. The engine then transforms the heat energy into kinetic energy by forcing the car into motion.
- The action of stopping the car is accomplished by brakes. By the action of friction, the brakes transform kinetic energy back to heat energy. When all the kinetic energy is transformed into heat energy, the car stops.

### 3.1.3 Power

Power is the rate at which work is done. It takes more power to work rapidly than to work slowly. Engines are rated by the amount of work they can do per minute. An engine that does more work per minute than another is more powerful.

The work capacity of an engine is measured in horsepower (hp). Through testing, it was determined that an average horse can lift a 200-pound weight to a height of 165 feet in 1 minute. The equivalent of one horsepower can be reached by multiplying 165 feet by 200 pounds (work formula) for a total of 33,000 foot-pounds per minute. The formula for horsepower is the following:

$$Hp = \frac{ft\ lb\ per\ min}{33000} = \frac{L \times W}{33000 \times T}$$

L = length, in feet, through which W is moved

W = force, in pounds, that is exerted through distance L

T = time, in minutes, required to move W through L

A number of devices are used to measure the hp of an engine. The most common device is the dynamometer, which will be discussed later in the chapter.

### 3.1.4 Torque

Torque, also called moment or moment of force, is the tendency of a force to rotate an object about an axis, fulcrum, or pivot. Just as a force is a push or a pull, a torque can be thought of as a twist.

In more basic terms, torque measures how hard something is rotated. For example, imagine a wrench or spanner trying to twist a nut or bolt. The amount of "twist" (torque) depends on how long the wrench is, how hard you push down on it, and how well you are pushing it in the correct direction.

When the torque is being measured, the force that is applied must be multiplied by the distance from the axis of the object. Torque is measured in pound-feet (not to be confused with work which is measured in foot-pounds). When torque is applied to an object, the force and distance from the axis depends on each other. For example, when 100 foot-pounds of torque is applied to a nut, it is equivalent to a 100-pound force being applied from a wrench that is 1-foot long. When a 2-foot-long wrench is used, only a 50-pound force is required.

Do **NOT** confuse torque with work or power. Both work and power indicate motion, but torque does not. It is merely a turning effort the engine applies to the wheels through gears and shafts.

### **3.1.5 Friction**

Friction is the resistance to motion between two objects in contact with each other. The reason a sled does not slide on bare earth is because of friction. It slides on snow because snow offers little resistance, while the bare earth offers a great deal of resistance.

Friction is both desirable and undesirable in an automobile or any other vehicle. Friction in an engine is undesirable because it decreases the power output; in other words, it dissipates some of the energy the engine produces. This is overcome by using oil, so moving components in the engine slide or roll over each other smoothly. Frictional horsepower (fhp) is the power needed to overcome engine friction. It is a measure of resistance to movement between engine parts. It reduces the amount of power left to propel a vehicle. Friction, however, is desirable in clutches and brakes, since friction is exactly what is needed for them to perform their function properly.

One other term you often encounter is inertia. Inertia is a characteristic of all material objects. It causes them to resist change in speed or direction of travel. A motionless object tends to remain at rest, and a moving object tends to keep moving at the same speed and in the same direction. A good example of inertia is the tendency of your automobile to keep moving even after you have removed your foot from the accelerator. You apply the brake to overcome the inertia of the automobile or its tendency to keep moving.

### **3.1.6 Engine Torque**

Engine torque is a rating of the turning force at the engine crankshaft. When combustion pressure pushes the piston down, a strong rotating force is applied to the crankshaft. This turning force is sent to the transmission or transaxle, drive line or drive lines, and drive wheels, moving the vehicle. Engine torque specifications are provided in a shop manual for a particular vehicle. For example, 78 pound-feet @ 3,000 (at 3,000) rpm is given for one particular engine. This engine is capable of producing 78 pound-feet of torque when operating at 3,000 revolutions per minute.

### 3.1.7 Chassis Dynamometer

The chassis dynamometer, shown in *Figure 2-15*, is used for automotive service since it can provide a quick report on engine conditions by measuring output at various speeds and loads. This type of machine is useful in shop testing and adjusting an automatic transmission. On a chassis dynamometer, the driving wheels of a vehicle are placed on rollers. By loading the rollers in varying amounts and by running the engine at different speeds, you can simulate many driving conditions. These tests and checks are made without interference by other noises, such as those that occur when you check the vehicle while driving on the road.

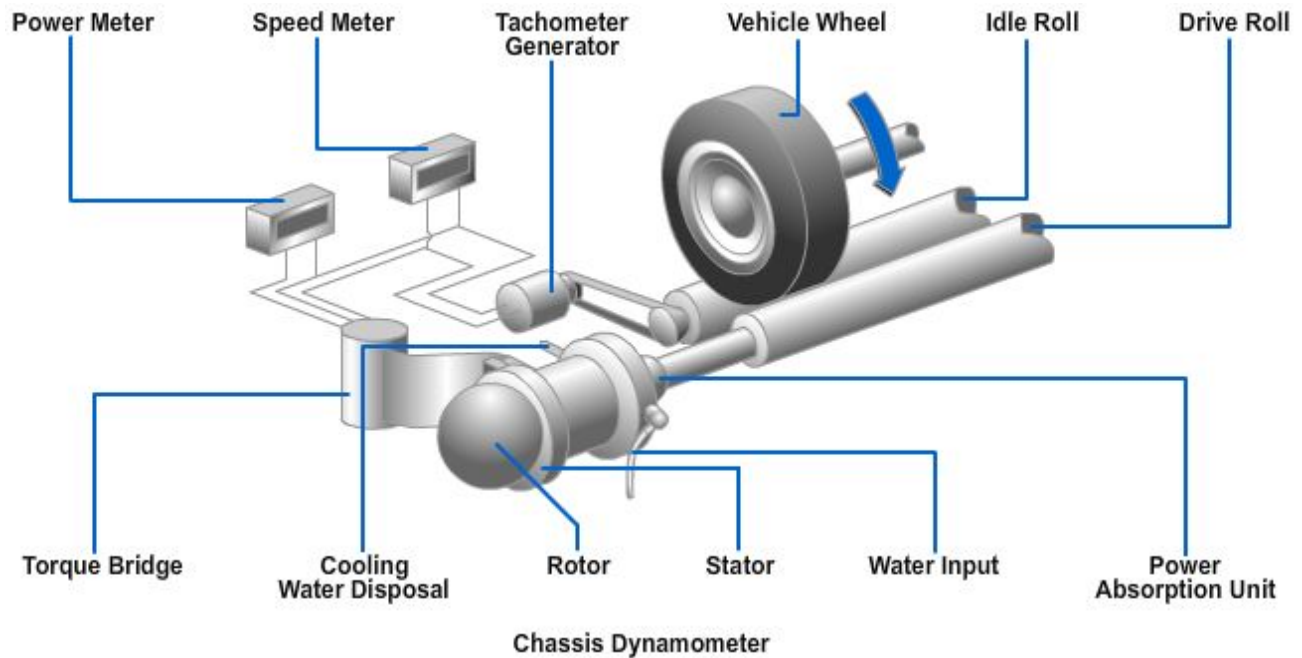

**Figure 2-15 — Chassis dynamometer.**

### 3.1.8 Engine Dynamometer

An engine dynamometer, shown in *Figure 2-16*, may be used to bench test an engine that has been removed from a vehicle. If the engine does not develop the recommended horsepower and torque of the manufacturer, you know further adjustments and/or repairs on the engine are required.

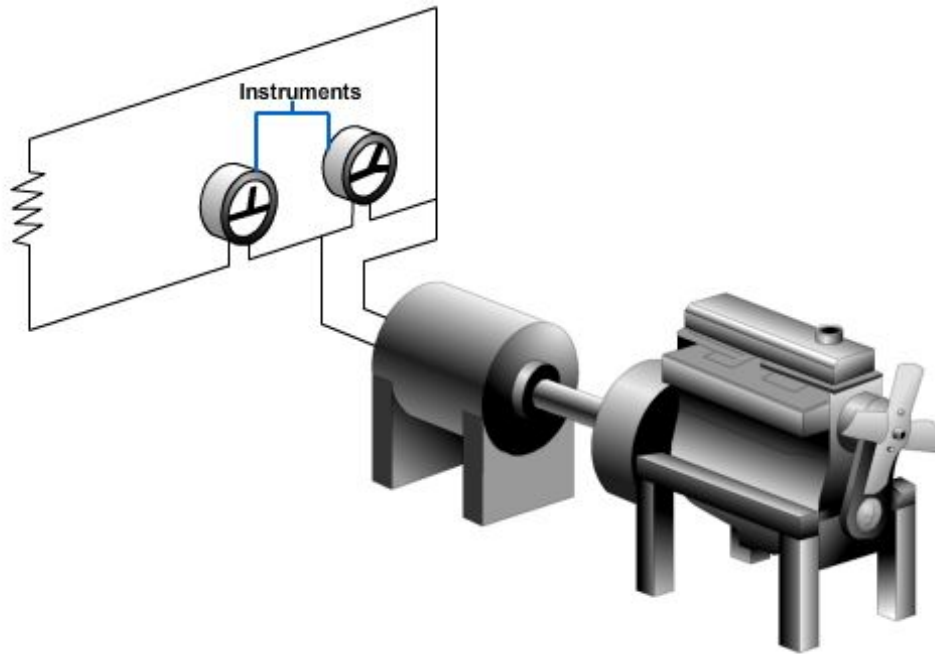

**Figure 2-16 — Engine Dynamometer.**

### 3.1.9 Mechanical Efficiency

Mechanical efficiency is the relationship between the actual power produced in the engine (indicated horsepower) and the actual power delivered at the crankshaft (brake horsepower). The actual power is always less than the power produced within the engine. This is due to the following:

- Friction losses between the many moving parts of the engine
- In a four-stroke-cycle engine, the considerable amount of horsepower used to drive the valve train

From a mechanical efficiency standpoint, you can tell what percentage of power developed in the cylinder is actually delivered by the engine. The remaining percentage of power is consumed by friction, and it is computed as frictional horsepower (fhp).

### 3.1.10 Thermal Efficiency

Thermal efficiency is calculated by comparing the horsepower output to the amount of fuel burned. It will be indicated by how well the engine can use the fuel's heat energy. Thermal efficiency measures the amount of heat energy that is converted into the crankshaft rotation. Generally speaking, engine thermal efficiency is 20-30%. The rest is absorbed by the metal parts of the engine.

### 3.2.0 Linear Measurements

The size of an engine cylinder is indicated in terms of bore and stroke, as shown in *Figure 2-17*. Bore is the inside diameter of the cylinder. Stroke is the distance between top dead center (TDC) and bottom dead center (BDC). The bore is always mentioned first. For example, a 3 1/2 by 4 cylinder means that the cylinder bore, or diameter, is 3 1/2 inches and the length of the stroke is 4 inches. These measurements are used to figure displacement.

### 3.2.1 Piston Displacement

Piston displacement is the volume of space that the piston displaces as it moves from one end of the stroke to the other. Thus the piston displacement in a 3 1/2-inch by 4-inch cylinder would be the area of a 3 1/2-inch circle multiplied by 4 (the length of the stroke). The area of a circle is  $\pi R^2$ , where R is the radius (one half of the diameter) of the circle. With S being the length of the stroke, the formula for volume (V) is the following:

$$V = \pi R^2 \times S$$

If the formula is applied to *Figure 2-18*, the piston displacement is computed as follows:

$$R = 1/2 \text{ the diameter} = 1/2 \times 3.5 = 1.75 \text{ in.}$$

$$\pi = 3.14$$

$$V = \pi (1.75)^2 \times 4$$

$$V = 3.14 \times 3.06 \times 4$$

$$V = 38.43 \text{ cu in.}$$

### 3.2.2 Engine Displacement

The total displacement of an engine is found by multiplying the volume of one cylinder by the total number of cylinders.

$$38.43 \text{ cu in.} \times 8 \text{ cylinders} = 307.44 \text{ cu in.}$$

The displacement of the engine is expressed as 307 cubic inches in the English system. To express the displacement of the engine in the metric system, convert cubic inches to cubic centimeters. This is done by multiplying cubic inches by 16.39. It must be noted that 16.39 is constant.

$$307.44 \text{ cu in.} \times 16.39 = 5,038.9416 \text{ cc}$$

To convert cubic centimeters into liters, divide the cubic centimeters by 1,000. This is because 1 liter = 1,000 cc.

$$\frac{5,038.9416}{1,000} = 5.0389416$$

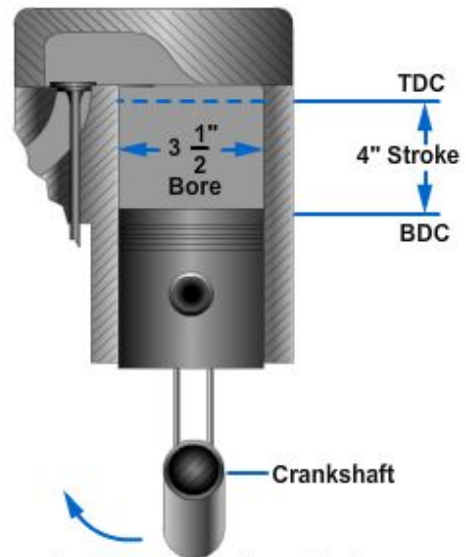

Bore and Stroke of an engine cylinder.

**Figure 2-17 – Bore and stroke of an engine cylinder**

The displacement of the engine is expressed as 5.0 liters in the metric system.

### 3.3.0 Engine Performance

#### 3.3.1 Compression Ratio

The compression ratio of an engine is a measurement of how much the air-fuel charge is compressed in the engine cylinder. It is calculated by dividing the volume of one cylinder with the piston at BDC by the volume with the piston TDC, as shown in *Figure 2-18*. You should note that the volume in the cylinder at TDC is called the clearance volume.

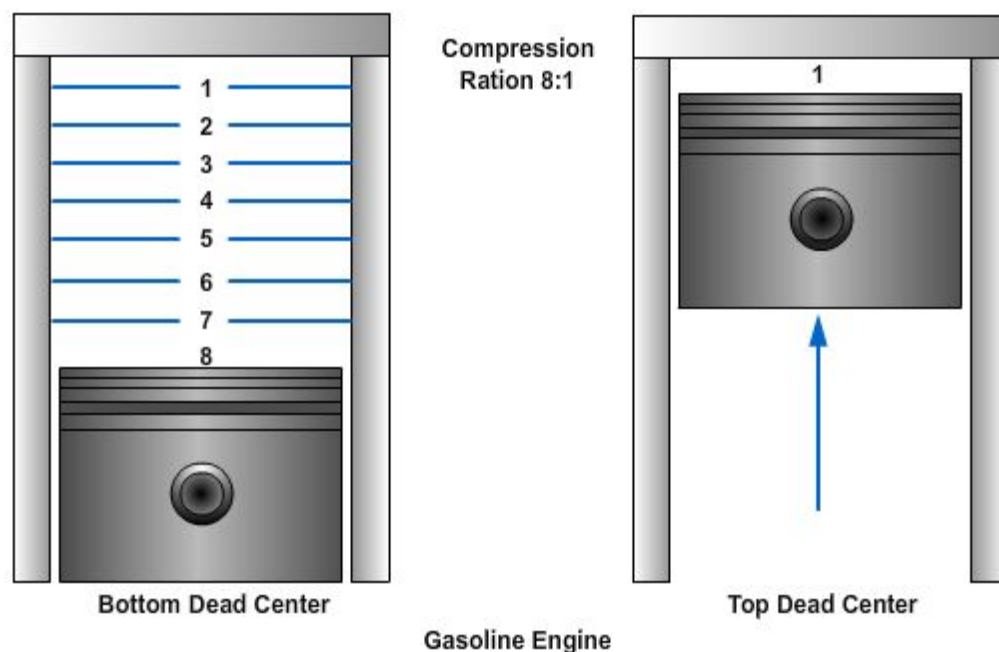

**Figure 2-18 — Compression ratio.**

For example, suppose that an engine cylinder has a volume of 80 cubic inches with the piston at BDC and a volume of 10 cubic inches with the piston at TDC. The compression ratio in this cylinder is 8 to 1, determined by dividing 80 cubic inches by 10 cubic inches, that is, the air-fuel mixture is compressed from 80 to 10 cubic inches or to one eighth of its original volume.

Two major advantages of increasing compression ratio are that both power and economy of the engine improve without added weight or size. The improvements come about because with higher compression ratio the air fuel mixture is squeezed more. This means a higher initial pressure at the start of the power stroke. As a result, there is more force on the piston for a greater part of the power stroke; therefore, more power is obtained from each power stroke.

Diesel engines have a very high compression ratio. Because the diesel engine is a compression-ignition engine, the typical ratio for diesel engines ranges from 17:1 to 25:1.

Factory supercharged and turbo-charged engines have a lower compression ratio than that of a naturally aspirated engine. Because the supercharger or turbocharger forces the fuel charge into the combustion chamber, it in turn raises the compression ratio. Therefore, the engine needs to start with a lower ratio.



### 3.3.2 Valve Arrangement

The majority of internal combustion engines are classified according to the position and arrangement of the intake and exhaust valves, whether the valves are located in the cylinder head or cylinder block. The following are types of valve arrangements with which you may come in contact:

**L-HEAD** —The intake and the exhaust valves are both located on the same side of the piston and cylinder, as shown in *Figure 2-19*. The valve operating mechanism is located directly below the valves, and one camshaft actuates both the intake and the exhaust valves.

**I-HEAD** —The intake and the exhaust valves are both mounted in a cylinder head directly above the cylinder, as shown in *Figure 2-20*. This arrangement requires a tappet, a pushrod, and a rocker arm above the cylinder to reverse the direction of valve movement. Although this configuration is the most popular for current gasoline and diesel engines, it is rapidly being superseded by the overhead camshaft.

**F-HEAD** —The intake valves are normally located in the head, while the exhaust valves are located in the engine block, as shown in *Figure 2-21*. The intake valves in the head are actuated from the camshaft through tappets, pushrods, and rocker arms. The exhaust valves are actuated directly by tappets on the camshaft.

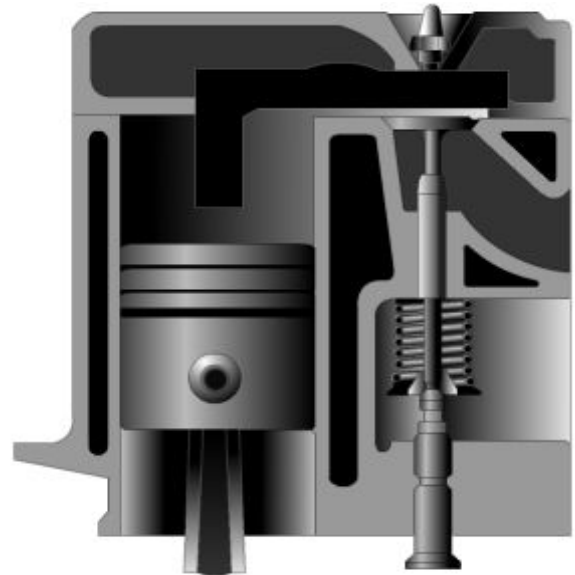

Figure 2-19– L-Head engine.

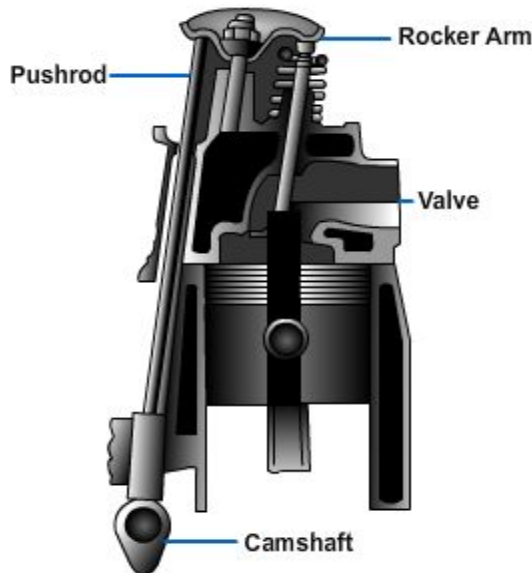

Figure 2-20 – I-Head engine.

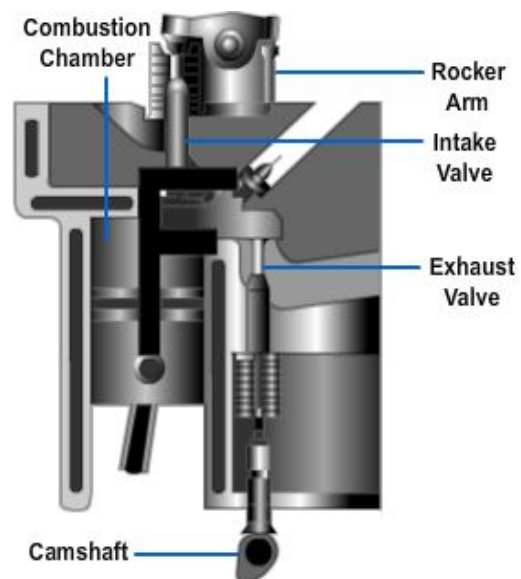

Figure 2-21 – F-Head engine.

**T-HEAD** —The intake and the exhaust valves are located on opposite sides of the cylinder in the engine block, each requires their own camshaft, as shown in *Figure 2-22*.

### 3.3.3 Cam Arrangement

There are basically only two locations a camshaft can be installed, either in the block or in the cylinder head.

The cam in block engine uses push rods to move the rocker arms that will move the valves.

In an overhead cam engine, the camshaft is installed over the top of the valves. This type of design reduces the number of parts in the valve train, which reduces the weight of the valve train and allows the valves to be installed at an angle, in turn improving the breathing of the engine. There are two types of overhead cam engines: single overhead cam and dual overhead cam.

The Single Overhead Cam (SOHC) engine has one camshaft over each cylinder head. This cam operates both the intake and the exhaust valves, as shown in *Figure 2-23*.

The Dual Overhead Cam (DOHC) engine has two camshafts over each head. One cam runs the intake valves and the other runs the exhaust as shown in *Figure 2-24*.

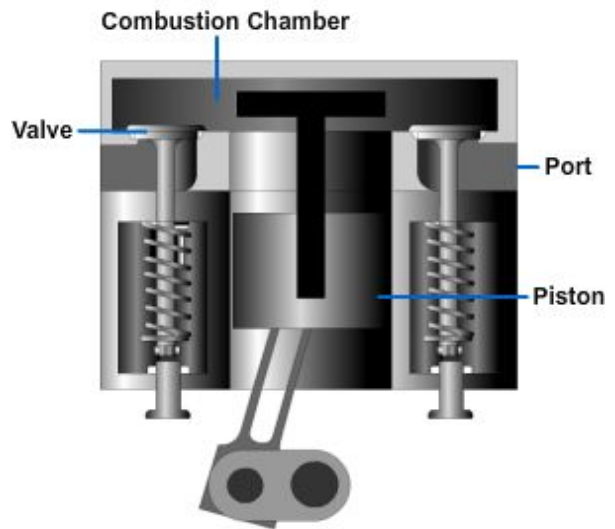

**Figure 2-22 – T-Head engine.**

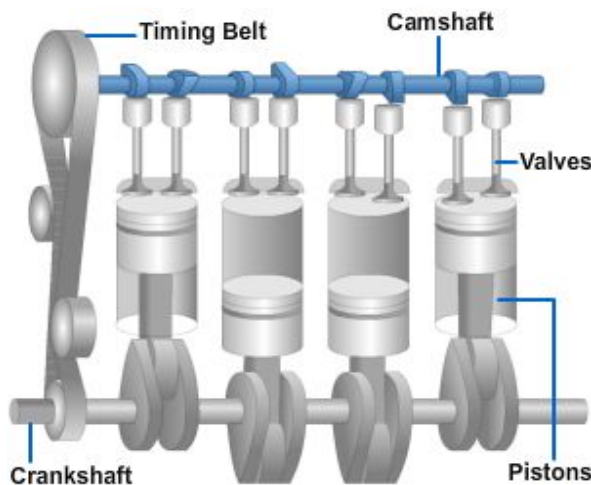

**Figure 2-23 – Single Overhead Cam.**



**Figure 2-24 – Dual Overhead Cam.**

### 3.3.4 Induction Type

An air induction system typically consists of an air filter, throttle valves, sensors, and connecting ducts. Airflow enters the inlet duct and flows through the air filter. The air filter traps harmful particles so they do not enter the engine. Plastic ducts route the clean air into the throttle body assembly. The throttle body assembly in multiport injection systems contain the throttle valve and idle air control device. After leaving the throttle body, the air flows into the engine's intake manifold. The manifold is divided into runners or passages that direct the air to each cylinder head intake port.

### 3.4.0 Timing

#### 3.4.1 Valve Timing

In an engine, the valves must open and close at the proper times with regard to piston position and stroke. In addition, the ignition system must produce sparks at the proper time, so power strokes can start. Both valve and ignition system action must be timed properly to obtain good engine performance.

##### 3.4.1.1 Conventional

Conventional valve timing is a system developed for measuring valve operation in relation to crankshaft position (in degrees), particularly the points when the valves open, how long they remain open, and when they close. Valve timing is probably the single most important factor in tailoring an engine for special needs.

##### 3.4.1.2 Variable

Variable valve timing means that the engine can alter exactly when the valves are open with relation to the engine's speed. There are various methods of achieving variable timing; some systems have an extra cam lobe that functions only at high speeds. Some others may include hydraulic devices or electro-mechanical devices on the cam sprocket to advance or retard timing.

#### 3.4.2 Ignition Timing

Ignition timing or spark timing refers to how early or late the spark plugs fire in relation to the position of the engine pistons.

Ignition timing has to change with changes in engine speed, load, and temperature, as shown in *Figure 2-25*.

Timing advance occurs when the spark plug fires sooner on the engine's compression stroke. The timing is set to several degrees before TDC. More timing is required at higher engine speed to give combustion enough time to develop pressure on the power stroke.

Timing retard is when the spark plug fires later on the compression stroke. It is the opposite or timing advance. It is needed when the engine is operating at lower speed and under a load. Timing retard

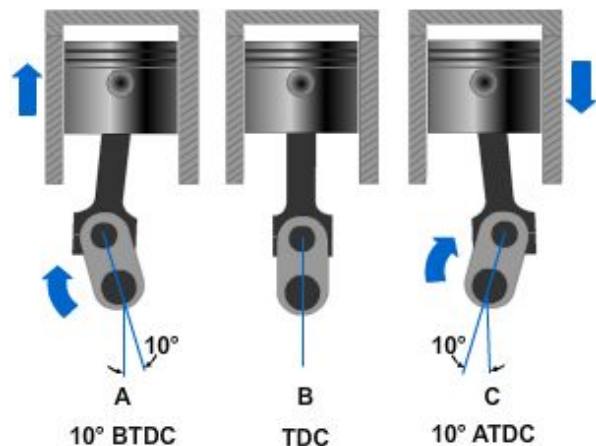

Figure 2-25 – Engine timing.

prevents the fuel from burning too much on the compression stroke that in turn causes spark knock or ping (an abnormal combustion).

### **3.4.2.1 Conventional**

There are two types of conventional ignition system spark timing: distributor centrifugal advance and distributor vacuum advance.

The centrifugal advance makes the ignition coil and spark plugs fire sooner as the engine speeds up. It uses spring-loaded weights, centrifugal force, and lever action to rotate the distributor cam or trigger wheel on the distributor shaft. By rotating the cam against distributor shaft rotation, spark timing is advanced. Centrifugal advance help maintain correct ignition timing for maximum engine power.

At lower engine speed, small springs hold the advance weights inward to keep timing retarded. As engine speed increases, the weights are thrown outward acting on the cam. This makes the points open sooner causing the coil to fire with the engine pistons farther down in their cylinders.

The distributor vacuum advance system provides additional spark at part throttle positions when the engine load is low. The vacuum advance system is a mechanism that increases fuel economy because it helps maintain ideal spark advance.

The vacuum advance mechanism consists of a vacuum advance diaphragm, a link, a movable distributor plate, and a vacuum supply line. At idle, the vacuum port is covered. Since there is no vacuum, there is no advance in timing. At part throttle, the vacuum port is uncovered and the port is exposed to engine vacuum. This causes the distributor diaphragm to be pulled toward the vacuum. The distributor plate is then rotated against the distributor shaft rotation and spark timing is advanced.

### **3.4.3 Electronic/Computer**

An electronic or computer-controlled spark advance system uses engine sensors, an ignition control module, and/or a computer (engine control module or power train control module) to adjust ignition timing. A distributor may or may not be used in this type of system. If a distributor is used, it will *not* contain centrifugal or vacuum advance mechanisms.

Engine sensors check various operating conditions and send electrical data representing these conditions to the computer. The computer can then analyze the data and change the timing for maximum engine efficiency.

Sensors that are used in this system include:

- Crankshaft position sensor- Reports engine rpm to the computer.
- Camshaft position sensor-Tells the computer which cylinder is on its power stroke.
- Manifold absolute pressure sensor- Measures engine intake manifold vacuum, an indicator of load.
- Intake air temperature sensor- Checks temperature of air entering the engine.

Engine coolant temperature sensor- Measures the operating temperature of the engine.

- Knock sensor- Allows the computer to retard timing when the engine pings or knocks.

- Throttle position sensor- Notes the position of the throttle.

The computer receives input signals from these many sensors. It is programmed to adjust ignition timing to meet different engine operating conditions.

## **Summary**

In order to be a successful mechanic, you must know the principles behind the operation of an internal combustion engine. Being able to identify and understand the series of events involved in how an engine performs will enable you to make diagnoses on the job, wherever you may be. During your career as a CM, you will apply these and other principles of operation in your daily job routines.

## **Additional Resources and References**

This chapter is intended to present thorough resources for task training. The following reference works are suggested for further study. This is optional material for continued education rather than for task training.

Modern Automotive Technology Sixth Edition, James E. Duffy, The Goodheart-Willcox Company, Inc., 2004. (ISBN-13: 978-1-59070-186-7)

Diesel Technology Seventh Edition, Andrew Norman and John "Drew" Corinchock, The Goodheart-Wilcox Company, Inc., 2007. (ISBN-13: 978-1-59070-770-8)