



*An Online PDH Course  
brought to you by  
CEDengineering.com*

## **The MEP Design of Building Services**

Course No: M06-034

Credit: 6 PDH

---

A. Bhatia

---



Continuing Education and Development, Inc.

P: (877) 322-5800

[info@cedengineering.com](mailto:info@cedengineering.com)

[www.cedengineering.com](http://www.cedengineering.com)

## THE MEP DESIGN OF BUILDING SERVICES

### Overview

People in urban settings spend between 80 and 90% of their time in indoor spaces both during work and during leisure time. It is therefore important that the Architect and the Mechanical, Electrical and Plumbing (MEP) engineers work in unison to ensure the quality environment. A good design can result in:

- Healthy and comfortable living
- Better environmental control
- Operational efficiency
- Lower greenhouse gas emissions
- Increased productivity

Remember MEP services are one area that makes the difference between comfortable and complaining occupants.

In this course, we will focus on “active” MEP services. The course comprises of 10 Chapters:

- CHAPTER – 1: KNOW YOUR BUILDING
- CHAPTER – 2: HVAC SYSTEMS
- CHAPTER – 3: AIR DISTRIBUTION SYSTEM
- CHAPTER – 4: FIRE FIGHTING SYSTEMS
- CHAPTER – 5: FIRE ALARM SYSTEMS
- CHAPTER – 6: VERTICAL TRANSPORTATION
- CHAPTER – 7: PLUMBING SYSTEMS
- CHAPTER – 8: ELECTRICAL SYSTEMS
- CHAPTER – 9: SPECIALTIES / COMMUNICATIONS + SECURITY
- CHAPTER – 10: MEP INTERFACE AND RELATIONSHIP WITH OTHER DISCIPLINES

## CHAPTER - 1 KNOW YOUR BUILDING

### CLASSIFICATION OF BUILDINGS

Buildings may be classified as low-rise, high-rise, and a number of other categories.

- Low-rise building is:
  - less than seven (7) stories or 75 ft. from street level. Most model codes adopt this classification which was originally based on the capacity of the firefighting truck ladders to reach the building heights effectively.
  - reached by conventional fire-truck ladders
- High-rise building: buildings from 7 to 29 stories
- Super high-rise building: 30 to 50 stories
- Skyscraper: 51 stories upward

### BUILDING EFFICIENCY FACTORS

Factors used to evaluate the effectiveness of the building design:

- Net-to-gross ratio (NGR)
- Floor-efficiency ratio (FER)

#### Net-to-Gross Ratio (NGR)

$$\text{NGR} = 100 \times \text{NFA}/\text{GFA}$$

Where

- NFA= net floor area, (ft<sup>2</sup>)
- GFA=gross floor area (ft<sup>2</sup>)

NFA is the usable floor area that can be used by the occupants, excluding the area taken by stairs, circulation space, elevators, lobbies, structural columns, MEP equipment and shafts. GFA includes the entire constructed floor area.

#### Floor- Efficiency Ratio (FER)

FER is used for office buildings to calculate the rentable space on typical rental floors.

$$\text{FER} = 100 \times (\text{NRA}/\text{GFA})$$

Where,

- NRA = net rentable area (ft<sup>2</sup>)
- GFA = Gross floor area (ft<sup>2</sup>)

Normally, an FER of 85% is considered an excellent design.

## GEOMETRIC FACTORS

Factors used to evaluate economics and energy-effectiveness relative to building geometry and form:

- VSR = volume-to-surface ratio
- APR = area-to-perimeter ratio

### Volume-to-Surface Ratio

$$\text{VSR} = V / S$$

Where,

- V = volume of building (ft<sup>3</sup>)
- S = total exterior surface of building (ft<sup>2</sup>)

The volume to surface area ratio of a building is an important factor in determining heat loss and gain. The greater the VSR ratio, the lower will be the heat gain/loss through it. A cost effective energy efficient building will therefore MINIMIZE exterior surfaces (walls and roof) and MAXIMIZE interior volume (floor area x height).

### Area - to - Perimeter Ratio (APR)

APR is the typical floor area divided by the perimeter length of the floor (most upper floors are substantially the same).

$$\text{APR} = A/P$$

Where,

- A = typical or representative floor area of building (ft<sup>2</sup>)
- P = linear dimension of perimeter of a typical or representative floor (ft.)

The surface area of the building is a function of the perimeter (aspect ratio) and the building height. The geometric shapes with an aspect ratio of 1:1 will have the minimum perimeter and will have the lowest surface area for a given height.

## WHAT MEP ENGINEERS SHOULD DEMAND FROM ARCHITECTURE

Heating, ventilating, and air-conditioning (HVAC) systems account for nearly 40% of the energy used in commercial buildings. The condition of your building envelope strongly influences HVAC system energy consumption and occupant comfort. Outlined below are strategies that can be used in buildings to conserve energy.

## Design for Correct Climate Zone

The Earth is a sphere, depending on where you are located, the sun will interact slightly differently than in other places. For example, the angle of the summer and winter sun will be different.

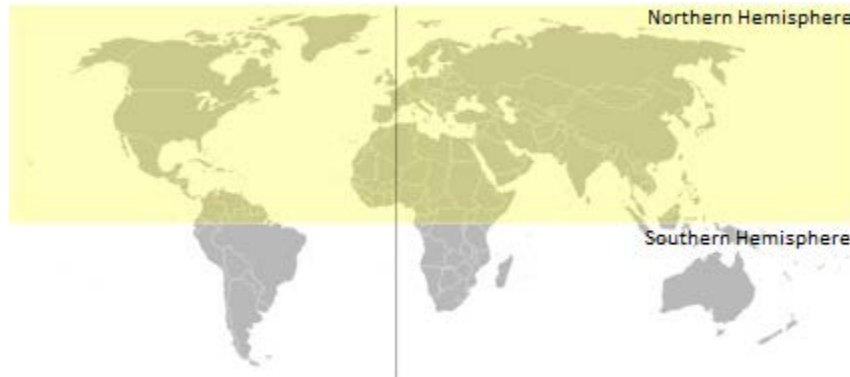

If the location is above the equator, in the northern hemisphere, the general direction for a building to receive sun throughout the day would be to face it to the south.

If the building's location is below the equator, within the southern hemisphere, the general direction to receive sun throughout the day would be to face the building to the north.

## Building Orientation

Orientation of a building should be done for the climatic zone in which the building is situated.

- **Cold climates:** The South facing side provides maximum solar gain. Locate the building's axis on the East-West direction with its longest dimension facing the South.
- **Hot and dry climate:** During summer, the North wall gets significant exposure, and the West side absorbs the maximum late afternoon heat. Similar to cold climates, longer walls of building should face North and South with longer axis along the East-West direction.
- **Warm and humid climate:** In this climate, buildings should ideally be long and narrow to allow cross-ventilation.

The optimum building orientation is somewhere along the east-west direction.

## Functions

An outline of the environmental conditions experienced in different areas of a building and how the area zoning should be assigned to the building is given below:

Area of the building	Environmental Conditions	Appropriate functions: office	Appropriate functions: residential
East facing	Will receive low angle sunlight and heat gain in the morning	Canteens, kitchens	Kitchens, dining areas, bedrooms
North facing	Will receive varying light throughout and sunshine throughout the day	Work areas, (high thermal mass elements such as stair cases – if passive solar strategy used)	Living, working areas (high thermal mass elements such as stair cases – passive solar strategy used)
West facing	Will receive low angle sunshine and heat gain in the afternoon	WCs, storage, service areas, lift shafts, staircases	Bathrooms, WCs storage areas
South facing	Daylight conditions will be even across the day and relatively little sunshine will be received.	Working areas, circulation, services, meeting areas	Bedrooms, circulation, services
Core of the building	Daylight and natural ventilation are likely to be relatively poor (without roof openings). Temperatures remain fairly steady	Lift shafts, stair cases, circulation, storage	Storage, circulation

### Walls and Roof

MEP engineers must recommend a wall with low conductivity (U-value or high R-value) to resist the heat gain or heat loss. High thermal mass (greater thickness) of material is preferred as this means high thermal storage capacity and less heat flow.

### Insulation

Insulation resists the heat flow through the building envelope. The energy consultants typically recommend wall insulation resistance between R-11 and R-19 and roof between R-19 and R-30.

### Glazing in façades

The glass in the building has a big influence in heat gain or heat loss. The following characteristics of glass can be used to promote energy efficient design.

- Low-E Glazing:
  - A single pane of glass has a U-Value of 1.11 Btu/ft<sup>2</sup> - hr °F. It decreases to 0.57 Btu/ft<sup>2</sup> hr °F for a 1/4" air space.
  - High performance glass with inert gas filled in double-glazing. Two choices exist:
    - Argon Gas: low cost
    - Krypton Gas: 200 x the cost of argon

- U-value for double glazed unit with argon gas in 1/4" space is .52 BTU/ft<sup>2</sup>-hr-°F
- Spectrally Selective Glazing:
  - Spectral coatings help block up to 80% of solar heat gain from entering the building. These can achieve a SHGC of 0.25.

### Day lighting and Ventilation

Arrange buildings to ensure good access to daylight and ventilation for nighttime cooling. Place important spaces and windows at southeast corner of the site; it will get more sun in the winter and less in the summer.

The depth of the building should not be more than 40 – 50 ft. Place windows on the south side to get winter sun into the space. Use northern windows for even daylight throughout the day.

### Shading devices

Shading devices should be used to avoid unwanted heat gains. Use architectural overhangs/fins/louvers and to some extent deciduous vegetation to block solar rays in the summer.

- Horizontal shading elements are appropriate on northern façades; and
- Vertical fins or moveable louvers are suitable on east and west façades to block solar rays.

### Color

The color of building affects heat absorption. The dark colors absorb more heat than lighter colors.

- In cold climates, the external surfaces of the walls should be dark in color for high absorptivity to facilitate heat gains.
- In hot and dry climates, light shade colors (having low absorptivity) should be used to paint the external surface particularly roofs and east and west façades. Darker shades should be avoided.
- In moderate climates, pale colors are preferable; dark colors may be used only in recessed places protected from the summer sun.

### BUILDING COSTS

- **Site Costs:** Site costs normally cover the owner's initial land acquisition and development costs for the project.
- **Construction Costs:** Construction costs are the portion of hard costs normally associated with the construction contract, including the cost of materials and the labor and equipment costs necessary to put those materials in place. Added to this are overhead costs, which include both job site management and the contractor's standard cost of doing business (office, staff, insurance, etc.).
- **Material Costs:** Material costs cover purchase of materials, including local and regional taxes, and shipping and handling costs, which include transportation, warehousing, and in some cases security. In very remote areas or in overseas locations, shipping, handling and other overheads may exceed the cost of the material.

- **Installation Costs:** Installation costs include the price of labor and equipment to put materials in place. Labor costs consist of base wages, taxes, insurance, and benefits, as well as premiums for overtime or for working in remote locations. Equipment costs include the direct cost of the equipment (whether it is a purchase amortization or a rental) and the cost of an equipment operator, which sometimes includes support staff.
- **Overhead Costs:** Overhead costs associated with construction are usually referred to as general conditions. These costs include those for field supervisory staff, additional professional services staff, engineering consultants, as well as temporary facilities and utilities, small tools, and a variety of safety and security equipment. Also included in this category are bonds, permits, and insurance costs allocated to the project. Contractors and subcontractors also incur general conditions costs.
- **Soft Costs:** Soft costs include a variety of costs incurred by the owner to move the project forward. Design fees, management fees, legal fees, taxes, insurance, owner's administration costs, and a variety of financing costs fall into this category.

## DESIGN FACTORS AFFECTING THE COST OF BUILDINGS

The building geometry and degree of articulation in the basic plan affect building cost. For example, from a cost perspective, a perfectly square footprint is the simplest to build and theoretically less expensive. Nonetheless, this geometry may be unacceptable and overly simplistic for most projects.

Building height and overall scale also influence building cost. For example, the cost of the structural system is likely to increase along with the building height.

System/Element	Principal Variable	Secondary variables
Foundations	Footprint area at grade	Soil conditions, site configuration, water table, seismic zone, weight, soil disposal, grade slab specs
Basement	Volume of basement	Soil conditions, soil disposal, water table and flow, depth of basement, type of soil retention, seismic zone
Superstructure	Area of supported floor and roof	Number of stories, floor-to – floor height, building configuration, loading, span and bay sizes, roof type and openings, seismic zone, MEP integration, type of cladding systems
Exterior closure	Areas of exterior closure	Area and type of fenestration and exterior doors, thermal and sound insulation requirements, seismic zone
Roofing	Area of roof	Roof configuration and type, number and types of openings, thermal and sound insulation requirements, extent of glazing



Interior construction	Gross floor area	Floor-to-ceiling heights, partition/wall density, flexibility required, extent of glazing and special features
Staircases	Number of flights	Floor-to-floor heights, fire regulations, staircase type
Interior finishes	Net floor area	Floor to-ceiling height, area of enclosed and finished spaces, type of ceiling, special finish requirements
Transportation	Number of stories	Capacity and speed required, type of drive systems, number of stories, building occupancy
Special construction	Building Function	Special user requirements for example, classrooms, a cafeteria, or a gymnasium in a school
General conditions	Value of construction	Time for construction, temporary utility availability, site access and storage, insurance, interest rates, market conditions
Sitework	Developed area of site	Site configuration and levels, paved areas, special features, demolition required, soil disposal and compaction, soil conditions, exterior lighting and utilities, extent of landscaping
Plumbing	Density of fixtures	Building occupancy, story heights, roof area, building configuration, special system requirements
HVAC	Heating and cooling load	Building occupancy and orientation, building area and volume, building configuration, story heights, thermal insulation provided, heat loss and gain, local climate
Fire protection	Area protected	Number of stories and story height, fire and insurance regulations, internal configuration
Electrical	Connected load	Building area, number of stories, building occupancy, standby requirements, lighting levels, power supply and distribution system

## CHAPTER - 2 HVAC SYSTEMS

In the context of mechanical building services, the internal environment refers to the strategy employed to heat, cool and distribute air around a building. Although Heating Ventilating and Air Conditioning equipment (HVAC) is the common terminology, Indoor Environmental Control Systems (IECS) is likely more accurate and more inclusive of all of the functions of air conditioning.

### COMFORT AIR CONDITIONING SYSTEM

The term comfort air conditioning encompasses all the conditioning processes applied to ambient air to obtain an indoor environment that is comfortable in terms of temperature, relative humidity, indoor air quality and air distribution.

- **Temperature:** The temperature conditions accepted as comfortable are 68°F to 75°F with 75±2°F as design goal.
- **Humidity:** The humidity conditions accepted as comfortable are 20 % to 60 % relative humidity with 55 ± 5 % as design goal.
- **Indoor Air Quality:** Outside fresh air requirement is about 15 to 20 cubic feet per minute (Cfm) per person.
- **Air Movement and Distribution:** HVAC system must move air to every nook and corner of the building to provide uniform environmental conditions, prevent objectionable drafts and limit noise decibel levels to 30 to 40 NC.

### MECHANICAL COOLING SYSTEMS

The most common active cooling approach is the use of “vapor compression refrigeration cycle”, which involves phase transformation of a fluid (called refrigerant) from a liquid to a gas. Compressing the fluid at a high-pressure releases heat, and when it is at a low pressure, it absorbs heat.

Cooling “load,” usually expressed in refrigerant tons (RT) or tons. A ton is a measure of refrigeration capacity.

One ton of air conditioning capacity is equivalent to the heat extraction rate of 3.5 kW or 12,000 Btu’s (British thermal units) per hour. A Btu/h, or British thermal unit per hour, is a unit used to measure the heat output of a heating system. One kWh of heat = 3414 Btu/h.

### REFRIGERANTS

Mechanical refrigeration equipment accomplishes cooling with Refrigerants.

In the past, chlorofluorocarbons (CFC) and hydrochlorofluorocarbons (HCFC) were used as refrigerants, but CFCs were phased out of production in the 1990s and HCFCs will be phased out of production by 2030 because of their ozone depletion potential.

The common environmentally friendly refrigerants used today in commercial air conditioning systems are the hydro-fluorocarbon (HFC) refrigerants include R-410A, R-407C and R-134a.

## COOLING SYSTEM OPTIONS

The climate systems used to actively cool buildings can generally be divided up into three types.

- Systems with air based cooling
- Systems with water based cooling
- Combined systems (cooling is supply using both air and water)

### Air based cooling (DX Systems)

DX stands for “direct expansion” and is term that use refrigerant as the cooling medium. With DX cooling, refrigerant flows through the cooling coil tubes and air is blown over the tubes covered with fins. The air does not come in contact with the refrigerant, but only to the cold metal surface of the coil. Since the air is cooled directly by the refrigerant, the cooling efficiency is higher. However, it is not always feasible to carry the refrigerant piping to the large distances hence, the DX type is usually used for cooling the small and medium sized buildings.

### Water based cooling systems

Three (3) types of HVAC systems utilize water in the cooling process:

#### Water-cooled system

The first type is water-cooled systems. These systems reject heat from the refrigerant to water in a water-cooled condenser. Typically, water enters the condensers at 80°F and leaves the condensers at 90°F. The water then goes to a cooling tower where a portion of the water is evaporated and the balance water with a mix of makeup water is circulated back to the condensers once again. Where water is scarce, dry coolers are used instead of cooling tower to prevent water loss due to evaporation.

#### Chilled water system

The second type of system is a chilled water system. In this type of system, water is cooled to 40 - 45°F by chillers in a central plant. This water is circulated throughout a building and runs through water coils in air handling units, leaving the coils at an approximate temperature of 55°F. Room air is drawn into the air handlers and is blown over the chilled water coils where it exits at a temperature of approximately 52°F. Like DX type cooling coil, the air does not contact the chilled water, but only the cold metal surface of the coil.

Since, the chillers are located remotely at a distance from the controlled space; it reduces noise, simplifies refrigerant handling, eases maintenance and improves reliability. These systems are truly centralized systems and found largely in high-rise or campus buildings.

#### Evaporative cooling system

The third type of system is known as an evaporative cooler or a swamp cooler sometimes called “nature’s air conditioner.” Just as a breeze across wet skin provides cooling as the moisture evaporates, an evaporative cooling does the same.

The dry air is passed through some porous media that is wetted with water. As the air contacts the water spread over the media, much of the water evaporates. It is normally only found in very hot and dry climates. Air is drawn into the cooler by a blower and passes over an absorbent pad. The pad is continuously soaked with water. As the hot dry air passes over the wet absorbent pad, some of the water is evaporated. This cools the wet pad the same way moisture evaporating from your skin cools your body. The air leaves the cooler at a reduced temperature. This temperature is dependent on the relative humidity of the air being drawn into the cooler.

### Combined systems

The combined hybrid system cooling is supplied using both air and water. The system can be configured in various forms. For example:

- The DX system may use the air-cooled condenser for heat rejection.
- The DX system may use the water-cooled condenser for heat rejection.
- The chilled water system may use the air-cooled condenser for heat rejection.
- The chilled water system may use the water-cooled condenser for heat rejection.

Some of the factors that must be taken into account when deciding the most appropriate HVAC configuration include:

- Space – HVAC equipment and the air/water distribution runs take up a lot of space in the building's floor plan. Maintaining building façade and aesthetics is an important concern to the architects.
- Cost – HVAC is usually the largest major budget item in construction of buildings. Air systems tend to be comparable to water systems in terms of initial cost.
- Comfort - Building success depends on how comfortable people are inside, and how affordable it is for them to be that way. Control of noise and vibrations is an important parameter.
- Efficiency - Water systems and air systems are comparable in terms of efficiency, water is a little better, but costlier.
- Maintainability – The equipment must be accessible for maintenance and replacement purposes.

## TYPES OF AIR CONDITIONING SYSTEMS

There is bewildering range of building air conditioning systems in the market today ranging from a small or medium capacity self-contained unit to central water chillers/boilers. While all of these HVAC systems share common basic elements, they differ in physical appearance and arrangement, price, performance and in manner of control and operation. Some drivers in selection are the design of the building itself – height, visibility of equipment, and proximity to surrounding buildings – while others factors entail the owner's preference – initial capital costs, aesthetics, and long term life cycle costs.

### Window Air Conditioners

Window-mounted AC units represent the largest category of portable AC appliances. Standard capacity range is 0.5 ton to 2 tons that can adequately cool 100 - 600 square feet. The design is

a DX (direct expansion) vapor compression cycle and the heat rejection is via air-cooled condenser. The appearance of window units both internally and externally is not the ultimate in aesthetics or class. Spoils external façade and often suffer from water dripping. See the figure below.



### Split Air Conditioners

Single split units are the most affordable type of standard air conditioning system, suitable for a single room (ductless) application. A split unit has two components: an outdoor metal cabinet and an indoor cabinet. That is why it is called a “split” system.

The outdoor cabinet contains the condenser and compressor and typically sits on a concrete slab outside your building. The indoor cabinet contains the evaporator and is usually located on the wall, in the attic or a closet. The indoor cabinet also typically includes a furnace (or the inside part of a heat pump). The indoor and outdoor units are connected by a refrigerant line.

The design is a DX (direct expansion) vapor compression cycle and the heat rejection is via air-cooled condenser.

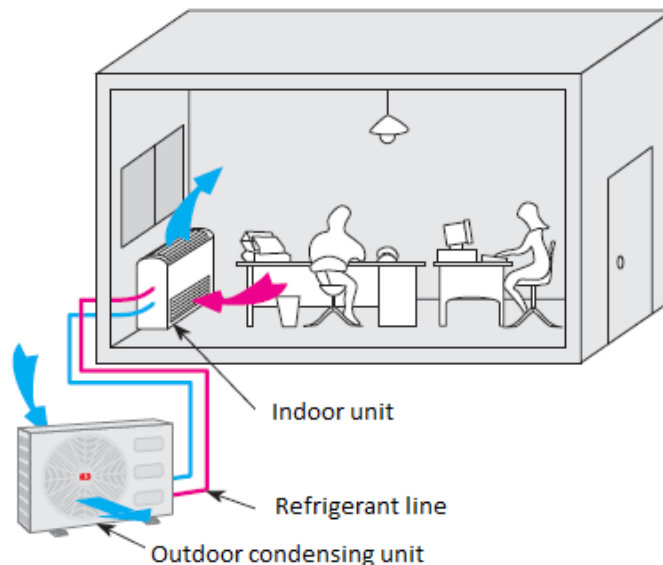

Compared to window air conditioner, the split units make less noise since the noise generating component (compressor) is usually in outdoor cabinet.

The split air conditioner system utilizes a direct expansion (DX) evaporator to cool air and air-cooled condenser to reject heat. The outdoor unit is usually pre-charged with refrigerant during manufacture. The majority of models currently being sold are “reversible” – they can operate as an air-conditioning unit in hot weather or can provide heating as an air-to-air heat pump in cold weather. In heating mode, the indoor unit functions as condenser and the outdoor unit as evaporator.

Indoor unit(s) can be ducted or non-ducted.

- Non-ducted indoor units can be either fixed – whether mounted high on a wall, floor-mounted or as ‘cassette’, ceiling-suspended, built-in horizontal or built-in vertical – or, mobile. The outdoor unit can be either fixed or mobile.
- Ducted indoor units can deliver cool air to several rooms or to several spots within a single room. The ducted units distribute the cool air evenly in the space. This is mostly used in hotels or large apartments.



## DISTRIBUTED SYSTEMS (LARGE DX AIR CONDITIONING)

This market sector includes air conditioning systems for medium range residential and commercial buildings with unit capacities varying from 3 to 50 tons. In distributed arrangement, with multiple units, the cumulative capacity can aggregate to any number. However, beyond a 200-ton capacity, one must perform the life cycle analysis to check the benefits of a centralized chiller system. The sector includes:

- Large multi-split air-conditioning
- Variable refrigerant flow (VRF) systems
- Ducted packaged units
- Rooftop units
- Heat pump units

All of these air conditioning systems utilize a direct expansion (DX) evaporator to cool air and air-cooled condenser to reject heat. This sector excludes small self-contained window and single split air-conditioning.

### Multi-Split System Air Conditioning

Multi-split units are simply a larger version of a small split consisting of several indoor units (up to around 10) connected to a single outdoor unit.

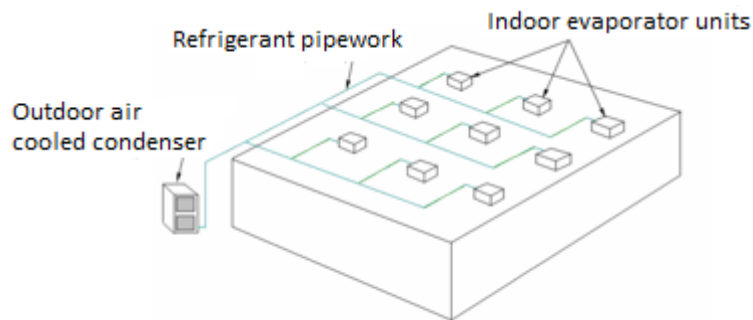

Typical Multi-Split System

The multi-split units are preferred if you do not want to install ductwork and if you want fewer outdoor units due to lack of outside space or else want to preserve your building's external appearance. They are most frequently used in places like restaurants, offices, doctor's surgeries and shops.

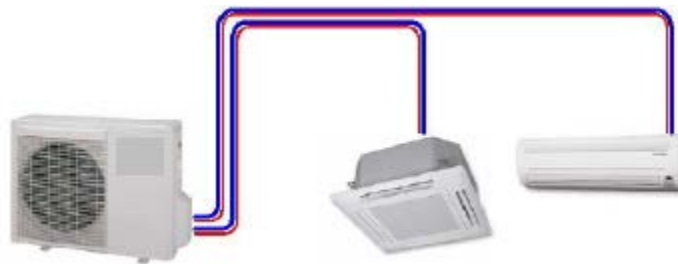

### Variable Refrigerant Flow (VRF) systems

The VRF (Variable Refrigerant Flow) system is similar in appearance to multi-split air conditioners. What makes the difference is the number of indoor units and the control function.

Multi-split system is generally limited to about 10 indoor units whereas the VRF systems can connect to more than 50 indoor units on a single outdoor condensing type. VRF systems use proprietary temperature control devices for efficient flow of refrigerant. The temperature control is available at every indoor unit and the outdoor unit adjusts the compressor load based on the heat load coming in from various units. The VRF HVAC system's compressor can detect the precise requirements of each zone, and send the precise amount of refrigerant needed to do the job. As a result, each area of your space is consistently comfortable with well-controlled humidity and no hot or cold spots.

Some of these systems are designed to be able to provide simultaneous heating and cooling to different parts of the same building (each indoor unit can be individually selected to provide either heating or cooling).

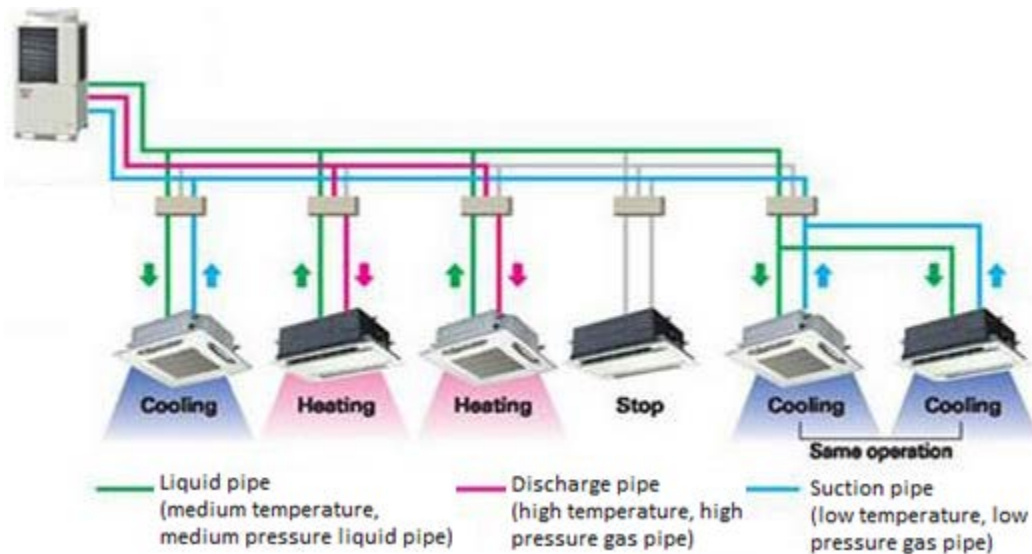

### Packaged Air Conditioning Systems

The HVAC industry has its own language to identify different equipment types.

“Unitary” refers to equipment that contains all of the components necessary to heat, cool, dehumidify, filter and move air in one or more factory-made assemblies. Unitary equipment is available in packaged or split system designs.

The most common type of commercial system is the packaged system design, which provides both heating and cooling to about 70 percent of the commercial building floor space built over the last 30 years. Packaged units are typically sized from five to 30 tons in cooling capacity. They are generally mounted on the rooftop but can also be installed at ground level. The evaporator and condenser are kept together in one package, delivering conditioned air directly into a room or ductwork.

### Types of Package Units

Three main types of package units are used for air conditioning. They can be distinguished by their mounting and blowing capability, vertical package, horizontal package and rooftops.

- **Vertical package** - Vertical package blow air horizontally or vertically upwards. The lower section normally contains the compressor, condenser and condenser fan, and the upper section the cooling coil and blower.
- **Horizontal package** - Horizontal package blow air horizontally. Typical cooling capacity product ranges between 3 and 20 tons.





Vertical unit



Horizontal unit

### Roof Top Packaged Units (RTU)

Roof-mounted units (RTU's) are installed on the roof and the air is blown downwards through the ductwork. The units are set on curbs that are flashed into the roof. Typical cooling capacity product ranges from 3 to 50 tons.

These are very commonly used in single-storey structure especially warehouses and super stores.



### Heat Pumps

A heat pump is an electric device used to pull heat out of air, ground or water and transfers it to the building. Heat pumps and air conditioners operate in a very similar way; the difference is that the heat pump cycle can be reversed to either heat or cool a controlled space.

Think about what would happen if you install the window air conditioner in reverse i.e. turning it 180°. Now, instead of transferring heat from inside the room to the outdoors, the air conditioner would be attempting to cool the great outdoors and transferring heat from the higher temperature outdoor air to the lower temperature air within the room. This heating process is called "Reverse

cycle air conditioning,” and this is what a heat pump is designed to do. It is designed to cool a space when operating as an air conditioner and it is designed to heat a space when the cycle is reversed. The actual reversal of the cycle is accomplished by reversing the flow of refrigerant and causing the indoor coil and the outdoor coils to switch roles.

Heat pumps are classified based on the fluid used for the heat source while the heat pump is operating in the heating mode. For example, a heat pump that uses air as its heat source when operating in the heating mode is referred to as an air-source heat pump. Also, a heat pump system that uses earth or water as its heat source when operating in the heating mode is classified as a ground source or water-source heat pump, respectively.

Two main types of heat pumps are:

**1. Air Source heat pumps**

- Heat is transferred from the low-temperature AIR outside to the high-temperature interior.

**2. Geothermal heat pumps**

- Ground source heat pump
  - Relies on the relative warmth of EARTH for its heating and cooling production
- Water source heat pump
  - Heat is transferred from low-temperature WATER outside (from a pond, lake or ground) to a high-temperature interior.

## WATER CHILLERS

Water chillers produce chilled water to condition the air. The chillers are classified according to the type of compressor they use. The major types of compressors are:

1. Reciprocating compressors usually find applications in residential and small commercial systems. Their capacity ranges between 10 through 200 tons.
2. Scroll compressors capacity ranges between 1 to 50-tons. Scroll compressors require less maintenance than reciprocating compressors.
3. Rotary screw compressors capacity ranges between 70 to 500 tons. These are much more efficient compared to the reciprocating compressors.
4. Centrifugal compressors capacity ranges between 100 to 7,000 tons. Centrifugal chillers especially driven with variable speed drive motor are the most efficient of the large-capacity chillers, but the drawback is that these are suitable only for water-cooled heat rejection.

The table below highlights the performance characteristics and applications of water chillers:

Type	Capacity tons	Refrigerant	Condensing media	COP	Power Demand, kW/ton	Characteristics & Applications
<b>Reciprocating</b>						Positive displacement compression, generally noisier and uses more power than rotary-type compressors.  Not appropriate if precise temperature control is required.
Semi-hermetic	10 - 200	HCFC -22	Water	4.7	0.7 -0.8	
Open	10 -150	HCFC -22	Water	4.7	0.7 -0.8	
Semi-hermetic	10 - 200	HCFC -22	Air	4.7	1.2 -1.4	
Open	10 -100	HFC - 134a	Air	4.7	1.2 -1.4	

Reciprocating compressor



50 to 60 tons



15 to 40 tons

Recipro compressor

Commercial/ industrial cooling systems up to 200 tons with water or air cooled condensers

<b>Rotary (Scroll &amp; Screw)</b>						Rotary chillers use single-screw or twin-screw compressors.  A positive displacement machine well suited to high-pressure refrigerants.  Provide significant operational energy savings because they can match full load or part load as small as 10 percent of the chiller's capacity.
Hermetic	70 - 500	HCFC -22	Water	4.7	0.6 -0.8	
Open	100 - 500	HCFC -22	Water	4.4	0.6 -0.8	
		HFC - 134a	Water	4.7	0.6 -0.8	
Hermetic	20 - 500	HCFC -22	Water	4.4	0.6 -0.8	
		HFC - 134a	Air	4.7	1.2 -1.4	



Screw compressors



Scroll chillers are available only in small capacities up to 50 tons.

Commercial and Industrial cooling systems up to 450 tons with water or air-cooled condensers.

Centrifugal						Centrifugal chillers use turbo-compressors with impellers that have high volumetric capacities because the flow of the refrigerant is continuous rather than intermittent.  Commercial and industrial cooling systems up to 8000 tons with water-cooled condensers only.
Direct-driven hermetic	100-3900	HCFC - 123	Water	4.8	0.55-0.65	
Open gear drive	150-7000	HCFC - 123	Water	4.8	0.55-0.7	
		HFC - 134a	Water	4.4	0.55-0.7	
Hermetic gear drive	100-2000	HCFC - 123	Water	4.8	0.55-0.7	
		HFC - 134a	Water	4.4	0.55-0.7	

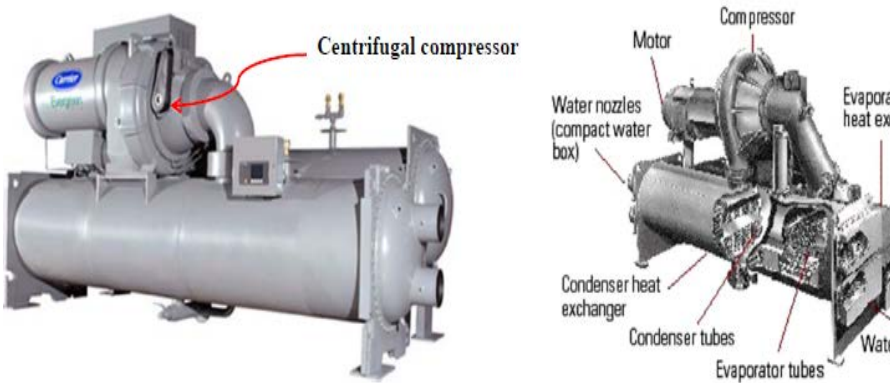

Absorption Chillers*						Commercial and industrial cooling systems generally used where heat/waste heat source is available.
Direct fired	100 - 1600	Water	Water	1.0		
Indirect fired, Steam/hot water	75 - 2000	Water	Water	0.6 (single stage)		
Indirect fired Steam/hot water	75 - 2000	Water	Water	1.2 (two stage)		

\*Absorption chillers are heat-operated devices that produce chilled water via an absorption cycle. These are not very common in commercial buildings and are used in industrial applications where heat source is available. Absorption chillers can be direct-fired, using natural gas or fuel oil, or indirect-fired. Indirect-fired units may use different sources for heat: hot water or steam from a boiler, steam from district heating, or waste heat in the form of water, air, or other gas. Absorption

chillers can be single-effect or double-effect, where one or two vapor generators are used. Double-effect chillers use two generators sequentially to increase efficiency. Several manufacturers offer absorption chiller/heater units, which use the heat produced by firing to provide space heating and service hot water.

### Design Variations of Compressors

- **Hermetic compressors** have the electric motor and compressor housed in a tightly sealed enclosure shell.
- **Semi-hermetic" compressors** that are similar to the hermetic type compressors but its shell can be dismantled.
- **Open type compressors** are externally coupled to the electric motor. All the main components are detachable and accessible.

### HEAT REJECTION EQUIPMENT

Heat rejection happens in equipment called “Condenser”. The heat rejection capacity of the condenser is usually 20 to 25% higher than the evaporator capacity and is sum of cooling load (evaporator capacity) and the energy added due to compression.

There are two types of condensers – air-cooled or water-cooled.

#### Air-cooled condensers

As the name suggests, the air cooled condensers use air to cool refrigerant vapor to the liquid state. These are located outside of the building envelope, through which refrigerant is circulated. As the refrigerant comes into indirect contact with outside air, heat is exchanged from the relatively hot refrigerant to the relatively cooler air. Heat exchange is enhanced by fan-forced flow of large volumes of air across the heat exchange coils.

Air-cooled condensers are offered on smaller and medium-range systems up to 120-tons capacity. They are initially less costly than water-cooled condensers, but are less efficient. The primary factor that influences the performance of the condenser is the outside air temperature. Higher ambient temperature reduces the performance.

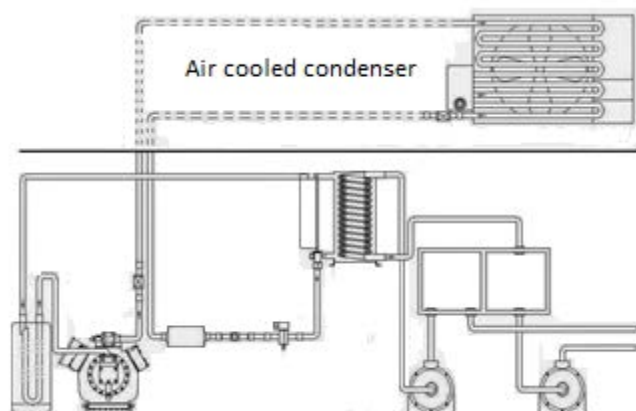

- Air-cooled heat exchangers are the only option where there is not enough water or the water is very expensive.
- The fan capacity normally ranges 500 -700 cfm of air per ton of refrigeration.
- Condensing temperatures range from 114 to 140°F, depending on climatic conditions. Higher condensing temperature will increase the power requirement and decrease the cooling system's performance.
- Advantages over water-cooled system:
  - No problem of water freezing
  - No water treatment required
  - No condensing water pump required
  - Lower initial cost

Air recirculation is very important for air-cooled chillers. Any obstruction in the circulation of air would adversely affect the performance. Air-cooled chillers can have problems with recirculation if there are walls higher than the unit or too many units to close together. If there is a situation where outside walls are required for building code and the unit will not be receiving enough fresh air, then a water-cooled application may be the best option.

### Water-cooled condensers

Water-cooled condensers are refrigerant-to-water shell and tube type design. These use water as the coolant, which is recirculated from a cooling tower or an evaporative dry cooler.

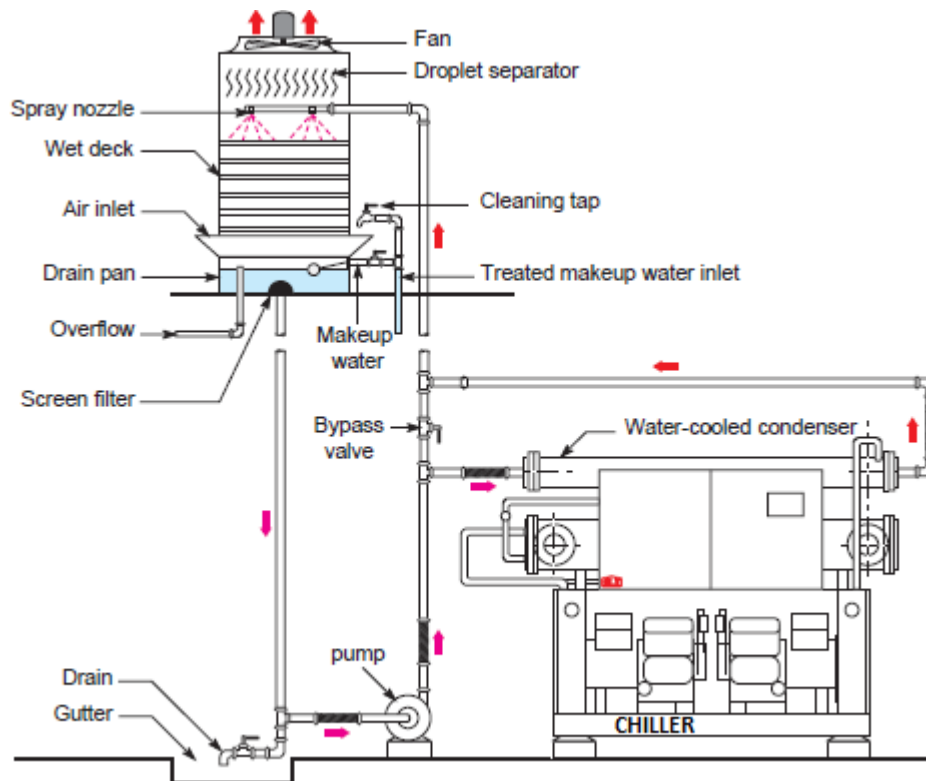

Cooling tower is a heat rejection device, installed outside of the building envelope, through which condenser water is circulated. Refrigerant in the refrigeration cycle is condensed in a shell and tube condenser. Heat rejected from the refrigerant increases the temperature of the condenser water, which must be cooled in a cooling tower to permit the cycle to continue.



### Structure of an induced draft, counter-flow cooling tower

Water-cooled chillers have longer life, higher efficiency, large capacity and refrigerant containment. They are recommended for large installations where there is sufficiency of water.

### Evaporative Dry Cooler

For air-cooled system, there also exists an evaporative-cooled condenser, where water is sprayed over the condenser coil to decrease the dry bulb temperature at the inlet of the condenser.



Cooling towers and evaporative condensers have main disadvantage of maintenance and water treatment costs. This running cost is not present in air-cooled chillers. Additionally, discharge air from cooling towers is humid and can contain droplets of water treatment chemicals. Surfaces exposed to the discharge air may become corroded, soiled, or discolored.

## CHAPTER – 3 AIR DISTRIBUTION SYSTEM

The method used to distribute heat and cool depends on the working fluid: water, refrigerant or air. Fresh air must be distributed by ducts or directed through the building volume itself. Ducts that use air as a working fluid need to be large since air does not store heat very effectively. Water is much denser and stores much more heat. For example, a 1-inch diameter pipe containing hot water can deliver more energy than air in an 8-inch x 12-inch duct. The working fluid may be moved by pumps, fans, gravity or natural convection.

### Air Handling Units

Central heating and cooling systems use the air-handling units (AHU's) and ductwork to distribute conditioned air to every nook and corner of the building.

An air-handling unit (AHU) is a device used to condition, circulate and modify the characteristics of air through variety of treatments such as filtration, heating, cooling, humidifying and dehumidification. The AHU maintains the optimum ratio of fresh air and exhaust air automatically on sensing higher CO<sub>2</sub> concentration in the indoor space. It also accomplishes the balancing of supply and return air while maintaining the building pressurization.

A standard air-handling unit is based around a packaged unit, which contains a blower, heating or cooling elements filter racks, sound attenuators, and dampers. Custom-built air handling units (AHU's) incorporates various add-ons such as heat recovery devices, economizers, smoke exhaust etc. to enhance safety and energy efficiency.



### Construction of Air Handling Unit

The construction and the physical location of the air handling unit is very important in the conceptual stages of architectural design otherwise it will be extremely difficult to establish the unit size and mechanical room area.

A modular air handling unit (AHU) assembly consists of multiple sections as indicated below:



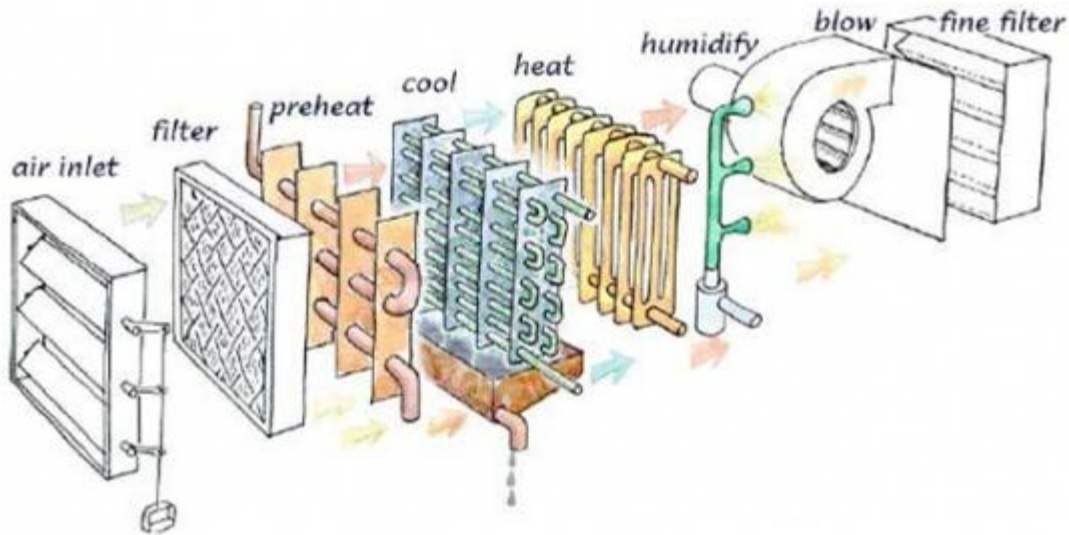

1. **Fan section** - Fan section contains a centrifugal fan to distribute air to the various zones of the building. The typical types of fan available are Backward Inclined, Backward Curved, Forward Curved and Airfoil. The selection of the fan will depend on the air volume and the static pressure required of the duct system.
2. **Cooling section** - Cooling section contains the cooling coil: DX or chilled water type. Both these coils are fabricated of copper tubes and aluminum fins. The difference is that the DX coil has a distributor at the inlet and the chilled water coil is connected to the header. The coils are available in different rows and fin spacing combinations. Higher rows are used when the moisture load is high (latent load) and lower fin spacing is preferred for reduced pressure drop. Lower row depth is used for sensible loads. The capacity of cooling coil is designed for cooling load of the space. Typically, there is a relationship between the cooling coil capacity and the fan capacity for standard units – 1 TR cooling coil capacity is equivalent to 400 Cfm of air flow.
3. **Heating section** - Heating section contains the hot water or steam coils for winter heating. Finned heat exchangers similar to cooling coil are applied with hot water or steam heating coil. The row depth of heating coil is lower since, it effects sensible heating only. Some air-handling units use electric heaters but these can also be applied directly in air ducts
4. **Humidification section** – Humidification section contains nozzles, spray headers or pan heaters. During winter, the humidity level of the air can be low causing discomfort and static electricity concerns. The humidity of the air can be increased by adding:
  - atomized water
  - water vapor supplied by steam boiler
  - water vapor supplied by small special steam-generating device
5. **Reheat section** - Reheat section contains heating coil for mitigating the low temperatures caused due to dehumidification. This is important when humidity control takes precedence over temperature control of cooling coil.
6. **Dehumidification** - There is not any specific section for dehumidification as it is done normally by the cooling coil itself. To increase dehumidification, the coolant temperature

in the cooling coil is lowered. The cool air would then be reheated in order to reach the required temperature and humidity conditions, typically with heat recovered in the system itself.

7. **Filters section** – Filter section contains the filters to capture the dust and other particulates. There are different types of filters available. High efficiency filters (those with a dust spot efficiency rating of 85% or higher) can remove pollen, mold spores, bacteria or other dusts, which may cause problems for people. Medium efficiency filters remove most dust and have a dust spot rating between 30 to 40%. Low efficiency filters will only remove large dust particles and are only intended to protect the coils. They do not remove mold spores or pollen. HVAC systems should use medium efficiency filters as a minimum.
8. **Mixing Box** – Mixing box contains dampers to maintain right proportion of supply air, return air and fresh air.
9. **Heat recovery** - Regarding heat recovery, systems used in AHUs are mainly cross-flow heat exchangers (efficacy 50%) and rotary wheels (60-70%). In smaller AHU sizes, exhaust air heat pumps can be used instead of the heat recovery device.

## Design Configurations

There are two types of AHU configurations - "Draw-Through" or "Blow-Through".

- **In the Draw-Through type**, the fan pulls the air through the filters and cooling coil before discharging it to the ductwork. In this configuration, the section before the fan has negative pressure. The design can be vertical or horizontal.
- **In the Blow-Through type**, the fan blows the air through the mixing box, filters and cooling coil before discharging to the ductwork. In this configuration, the section after the fan has positive pressure. The design is normally horizontal.

## AIR DISTRIBUTION SYSTEM DESIGN

Air can be distributed and conditioned by variety of designs. Three common systems are:

1. All-air systems
2. Air-and-water systems
3. All-water systems

### System 1: All-air Systems

In all-air systems, the conditioned air is produced centrally at AHU located in a mechanical room and distributed via ductwork. It is normally the cheapest to procure but is not necessarily cheap to install due to the size of ducting required and the cost of lifting.

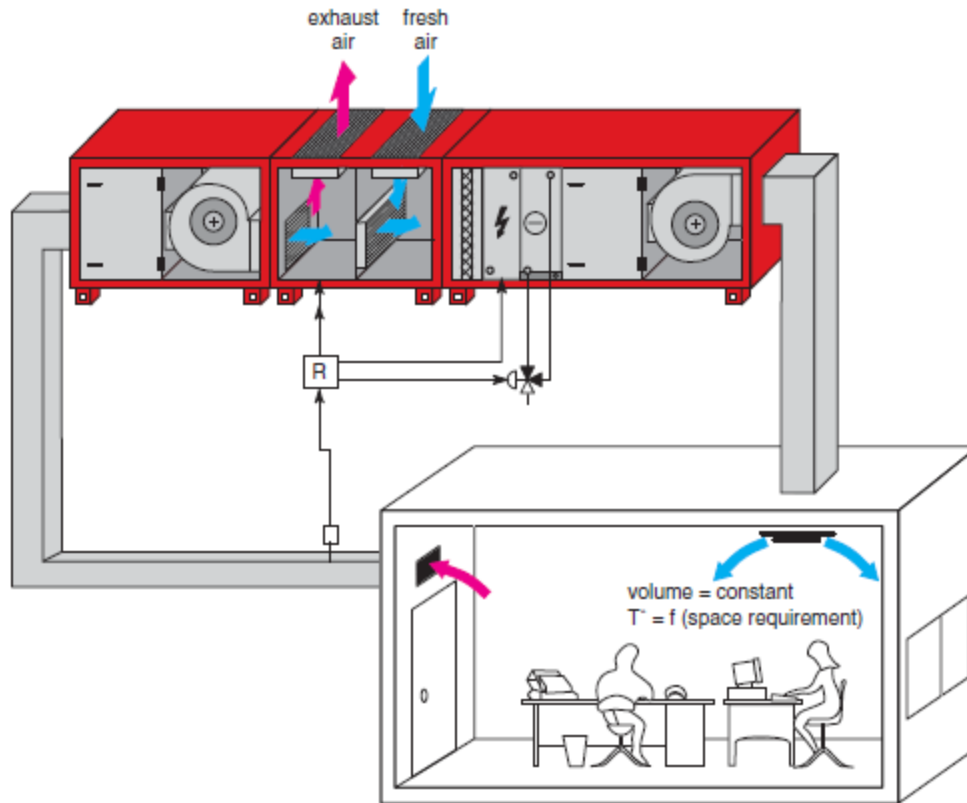

Control of dry-bulb temperature within a space requires that a balance be established between the space load and the air supplied to offset the load. To maintain the balance, you can choose between varying the supply air temperature or varying the volume as the space load changes.

There are two major configurations of all air systems:

- Constant volume single zone systems
- Variable air volume (VAV) systems

### Constant Air Volume (CAV) Systems

Constant Air Volume (CAV) is a type of air conditioning system, where the airflow is maintained constant, but the air temperature is varied to meet the thermal loads of a space.

These systems are simple, low cost and easy to commission, but they cannot provide adequate control for zones, which have different heating or cooling needs. CAV systems are typically applied to single temperature controlled zone. A single-zone system responds to only one set of space conditions.

Its use is limited to situations where variations occur almost uniformly throughout the zone served or where the load is stable. A single-zone system would be applied to small department stores, large factory spaces, supermarkets, assembly halls, individual classrooms of a small school, computer rooms, etc.

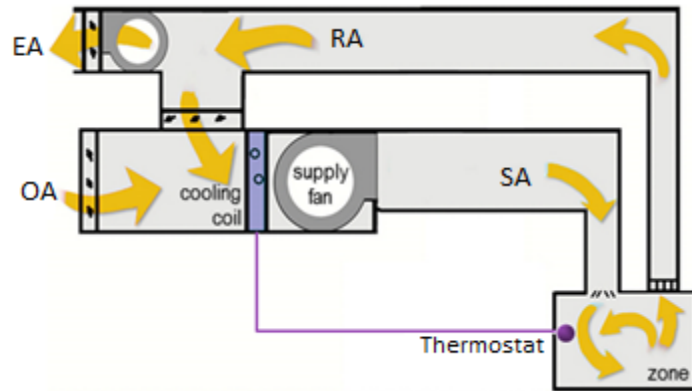

### CAV Reheat System

The reheat system is a modification of the single-zone CAV system. When multiple zones of temperature are required, you may choose to provide separate single zone CAV system for every zone, increasing capital costs and plant room space or provide a reheat system.

In a reheat system, the conditioned air is supplied from a central unit at a fixed cold air temperature designed to offset the maximum cooling load in the space. A heater coil is installed in supply air duct for each zone, which is energized only when the control thermostat calls for heat as the cooling load in the zone drops below maximum. This system is generally applied to hospitals, laboratories, or spaces where wide load variations are expected.

This is not a very efficient way, since the air is cooled and then reheated incurring excessive energy use and therefore not permitted by many state codes. In lieu of reheat systems, variable air volume (VAV) systems are recommended.

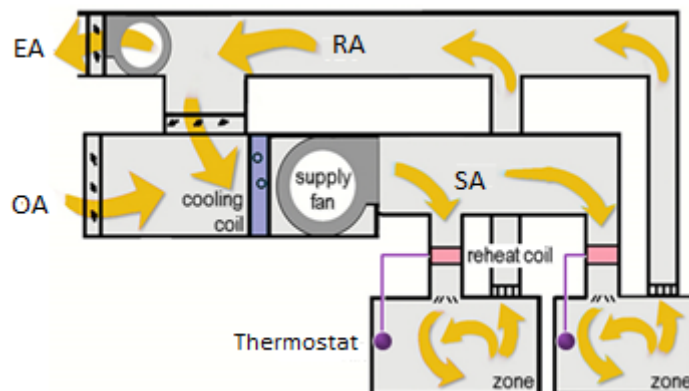

### Variable Air Volume (VAV) Systems

Variable air volume (VAV) is a type of air conditioning system where the supply air temperature is set constant and the airflow rate is varied to meet the rising and falling heat gains or losses within the thermal zone. The air flow to each zone is controlled by a damper box (VAV box) directly connected to the branch duct, while central supply and exhaust air fans are controlled by means of variable speed fan motors, usually frequency controlled. Control usually occurs to maintain a constant static pressure in one of the branch ducts furthest away.

VAV systems are much more energy efficient and provide better temperature control compared to CAV systems. The drawback is that the humidity control is not optimal and a number of adaptations may be required. These systems also complicate the delivery of outdoor air. If the fraction of outdoor air is constant, the total volume of outdoor air will be reduced as the supply air volume is reduced. This would occur during partial-load conditions and may cause indoor air quality problem.

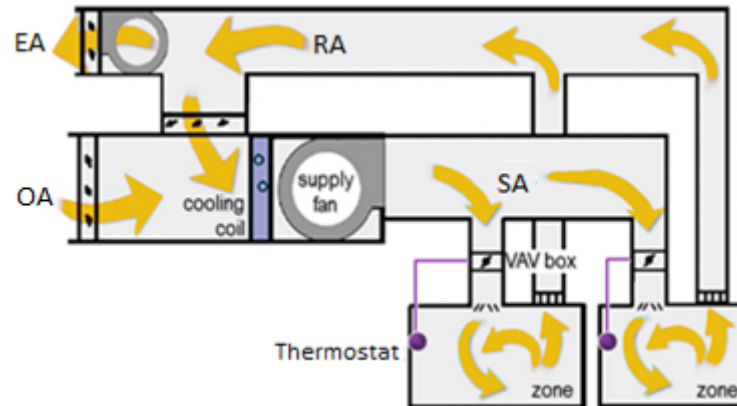

Variable air volume systems may be applied to interior or perimeter zones with common or separate fans systems, common or separate air temperature control, and with or without auxiliary heating devices. It is possible to vary zone air volume only, while keeping fan and system volume constant by dumping excess air into a return air ceiling plenum or directly into the return air duct system.

When you design All Air Systems, remember the following:

- All air systems comprise one or more larger mechanical spaces for locating air-handling units, which may occupy significant floor areas. The mechanical room area may be as high as 4 to 10% of the floor area depending on the cooling unit's design configurations. In multi-storey buildings, vertical chases are required, which reduces the amount of usable space and may limit the flexibility to partition the space.
- Air-handling mechanical room requires careful detailing. Mechanical rooms should be centrally located to minimize ductwork. Horizontal runs of ductwork influence the ceiling height.
- Special acoustical treatment is required if rooms are adjacent to sound-sensitive areas (e.g. Conference Rooms).
- Air-intake and exhaust should be located on different walls, where possible, or no closer than 10 feet apart when located on the same wall.

### Applications of All Air Systems

- All Air Systems is a recommended option for applications with high occupancy or places with high public gathering such as cinemas, theaters, auditorium, function halls, retail stores, meeting rooms, airports, hotel lobbies etc. These places require large amount of clean outside air to dilute the contaminants and achieve good air quality.
- For many commercial air conditioning tasks, the internal environment is both contaminated by smells and pollutants. The applications such as IT Data centers, Research Labs,

Process industries, Clean rooms, Operation Theatres, Hospitals etc. have significant thermal loads and pollutants. These are best addressed by all air systems.

### Disadvantages

- The biggest drawback of all air systems is that it would require a high airflow rate resulting in large ducts, ceiling space and high energy costs for the air distribution system. The air distribution and performance are difficult to balance.

### System 2 – All Water Based Systems

A hydronic, or all-water, system is one in which hot or chilled water is used to convey heat to or from a conditioned space or process through piping connecting a boiler, water heater, or chiller with suitable terminal heat transfer units located at the space or process.

All water systems may be classified by temperature, generation of flow, pressurization, piping arrangement, and pumping arrangement.

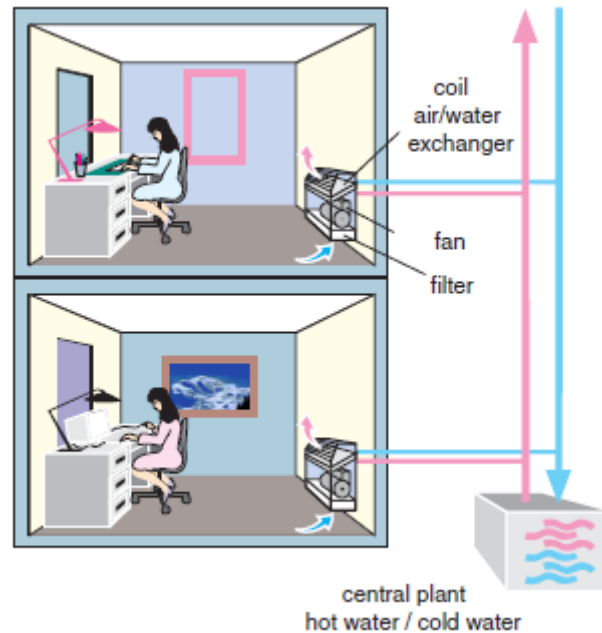

### Chilled Water System, CWS

A CWS is a chilled water cooling system operating with a usual design supply water temperature of 40 to 55°F and normally operating within a pressure range of 125 psi. Antifreeze or brine solutions may be used for systems usually process applications that require temperatures below 40°F. Well water systems may use supply temperatures of 60°F or higher.

### Hot Water Systems, HWS

Hot water systems are often called hydronic systems and are classified as Low temperature water system, Medium temperature water system and High temperature water system.

- **Low-Temperature Water System LTW:** An LTW is a hot water heating system operating within the pressure and temperature limits of the ASME boiler construction code for low-pressure heating boilers. The maximum allowable working pressure for low pressure heating boilers is 160 psi with a maximum temperature limitation of 250°F. The usual maximum working pressure for boilers for LTW systems is 30 psi, although boilers specifically designed, tested, and stamped for higher pressures may frequently be used with working pressures to 160 psi.
- **Medium-Temperature Water System MTW:** An MTW is a hot water heating system operating at temperatures of 350°F or less, with pressures not exceeding 150 psi. The usual design supply temperature is approximately 250 to 325°F, with a usual pressure rating for boilers and equipment of 150 psi.
- **High-Temperature Water System HTW:** An HTW is a hot water heating system operating at temperatures over 350°F and usual pressures of about 300 psi. The maximum design supply water temperature is 400 to 450°F, with a pressure rating for boilers and equipment of about 300 psi. It is necessary that the pressure-temperature rating of each component be checked against the design characteristics of the particular system.

The biggest advantage of all water systems is that because of the greater specific heat and much greater density of water compared to air, the cross sectional area required for the distribution pipes is much less for the same cooling task. The drawback is that it is difficult to provide the outside air for ventilation and it has to be dealt with separately. System is not applicable to spaces with high exhaust requirements.

### Applications of All Water Systems

- All water systems are suitable for use as low cost central HVAC systems in multi zone high rise commercial applications.
- All water system is preferred over all air systems, where ceiling height is low. It is much easier to carry water through small sized pipes than air through very big sized ducts.
- All water system provide individual room control as required in hotels, multi storey apartments, offices etc.

### Terminal units

Air terminal units can be considered as a local air-handling device for individual zones within a building. These facilitate heat transfer between the conditioned water and the occupied space. These are essentially 100% recirculation units and do not provide ventilation air.

Terminal units used in all water system are of three types namely Fan coil units (FCU), Convector and Radiator

### Fan Coils Units (FCU's)

A fan-coil is a terminal unit that drives air past a finned tube containing hot or cold fluid. The air is usually drawn from the space to be conditioned and returned to it. They may be combined with filtration and may mix untreated outdoor air into the stream.

The central plant delivers hot or cold water to fan units. The piping can be designed as two or four pipe system. A two-pipe unit has a set of supply and return pipes that can carry either hot or chilled water. A four-pipe unit has two sets of piping – one set of supply and return for chilled water and another set for hot water connected to central boiler. The four-pipe system is more flexible but more expensive to install.

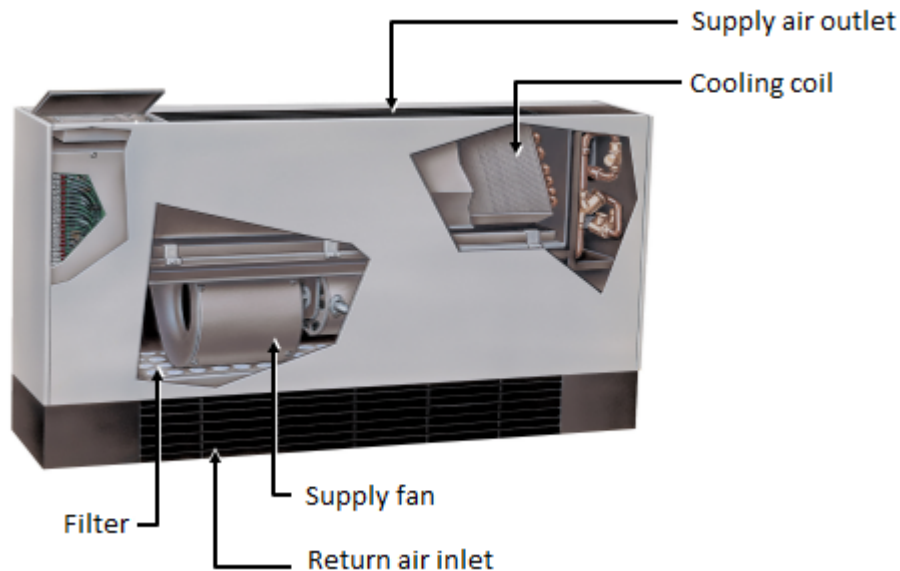

Fan coil systems can provide multi-zone control of temperature without the need for reheat, and can cope with situations where simultaneous heating and cooling may be required.

They are rather efficient since they obviate the need to blow large quantities of air around a building, but do require decentralized maintenance (filter changes, condensate pan cleaning, etc.).

These units are available in various configurations to fit under window sills, above furred ceilings, in vertical pilasters built into walls, etc. These are mainly used as ductless systems but can be connected to ductwork also.

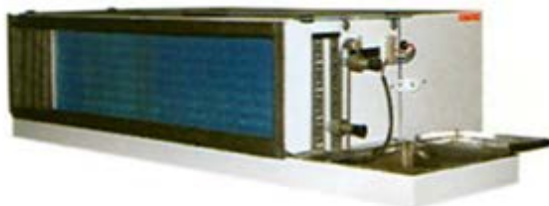

**Horizontal ceiling-recess-mounted FCU**



**Vertical high-wall-mounted FCU**





Horizontal ceiling-surface-mounted FCU



Vertical floor-mounted FCU

## Radiators

A radiator is a heating device that is installed in the space to be heated and transfers heat primarily by radiation. The most common example is the sectional cast-iron column radiator. There are many thousands of these in use throughout the world, although, in new installations, they have been largely supplanted by convector radiators or baseboard radiation. The heat source is hot water or low-pressure steam 5 psig or less. Small "electric radiators" include water and an electric immersion heater.

Radiators are rated in square feet of radiation, or EDR equivalent direct radiation. One square foot EDR is equal to 240 Btuh for steam at 1 psig or 180 Btuh for water at 200°F. These ratings are no longer readily available but may be obtained from the Hydronics Institute, formerly the Institute of Boiler and Radiator Manufacturers. Some representative data is available in the ASHRAE Handbook.

## Convectors

A convector is a heating device that depends primarily on gravity convective heat transfer. The heating element is a finned-tube coil, or coils, mounted in an enclosure designed to increase the convective effect, as shown in figure below. The enclosure cabinet is made in many different configurations, including partially or fully recessed into the wall. The usual location is on an exterior wall at or near the floor. Capacity depends on geometry - length, depth, height - and heating element design, as well as hot water temperatures or steam pressure.



Convectors save energy over conventional radiators because the space heats up quickly and because the temperature of the water may be lowered. Common applications are:

- Baseboard convectors – residential use
- Fin-tube convectors – commercial applications

### Chilled ceilings/beams

A chilled beam is a building cooling device that circulates air using the principles of natural heat convection. The major advantage of a chilled beam over more common forced air systems is that it circulates building air without the noise and expense of ductwork and air handlers. Typically mounted overhead near or within a ceiling, the beam is a type of radiator, chilled by an external source such as Recirculated water. It cools the space below it by acting as a heat sink for the naturally rising warm air of the space. Once cooled, the air naturally drops back to the floor where the cycle begins again.

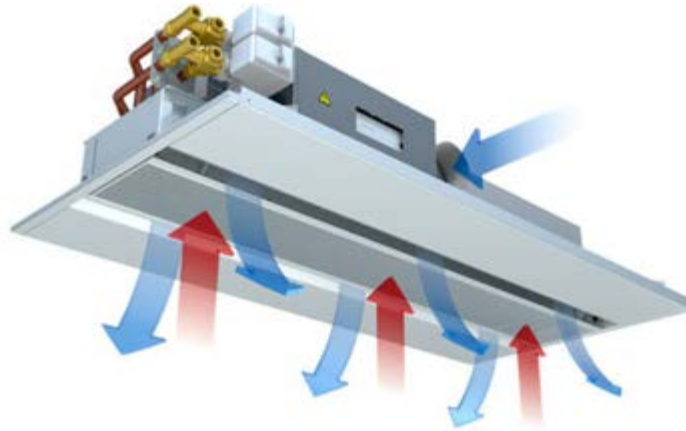

Chilled ceiling/beams use chilled or cooled water (normally between 55 to 65°F) as the cooling medium. “Free cooling” may be utilized if a suitable source of groundwater is available.

There are three generic types of chilled ceiling/beams:

1. Radiant ceiling panels - Cooling is principally achieved via the process of radiant exchange. Typically, 60% of the cooling output is achieved through this heat transfer mechanism. Serpentine chilled water pipework is incorporated within the ceiling panels.
2. Passive chilled beams - Cooling is achieved by natural convection, by passing chilled water through finned elements (similar in form to a heat exchanger). The beams can be installed flush with false ceilings or can be fully exposed in aesthetic casings.
3. Active chilled beams - Similar to passive chilled beams, except that the air moving through the beam is mechanically assisted. The air is supplied to the room through diffusers built into the beam.

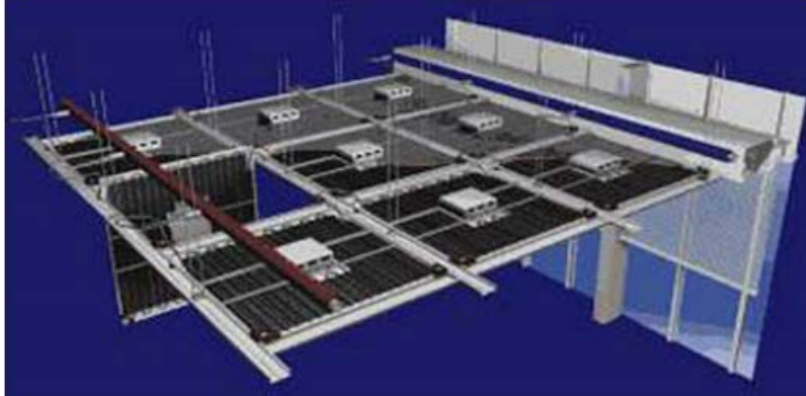

Chilled ceilings and beams only provide comfort cooling. Filtration, heating and humidification are not available.

With active chilled beams, ventilation is provided from the central plant, and filtration may be provided.

With passive chilled beams and ceiling panels, ventilation has to be introduced separately. This is normally achieved by displacement ventilation.

Chilled ceilings and beams must be controlled to prevent the risk of condensation. This can be achieved by incorporating condensation detection into the chilled beam control system.

#### **All-water system advantages**

- Improved efficiency of space utilization;
- Lower energy costs;
- Individual temperature control; and
- Architectural flexibility: With the ability to install units in the floor, ceilings or walls/façades, there is always an option to meet specific requirements.

#### **All-water system disadvantages**

- Do not filter or ventilate effectively;

- Do not satisfy ventilation air intake or exhaust rate needs;
- Lack humidity control;
- Must be switched over for seasonal operation; and
- Require a great deal of maintenance.

### System 3: Air and Water Systems

Air based and water based cooling can be combined in many different ways. One situation when the systems must be combined is when the air-based system does not have sufficient cooling capacity. The other situation may be the air system is used to provide the outside air for ventilation and building pressurization while terminal units utilizing fan coil units are used as in all water system.

#### Applications of Air water systems:

- It is much suitable for retrofitting of existing buildings, where there is space restriction;
- It is very good solution for perimeter zone buildings with large sensible loads;
- It can be used where close control of humidity in the space is not necessary; and
- It serves well for large office buildings, hotels, lodges etc.

#### Advantages of air-water systems

- Air water systems require comparatively low air flow rates (only for ventilation). This means that the required air supply and extract duct cross sectional areas are significantly reduced;
- Provides ventilation and humidity control; and
- All advantages of All-water systems.

#### Disadvantages of air-water systems

- Between-the-season operation is difficult to manage; and
- Normally limited to exterior zones.

### AIR DISTRIBUTION DUCTWORK

Duct system provides a controlled path for airflow throughout the building to deliver and remove air. The needed airflows include, for example, supply air, return air, and exhaust air. In a typical central air-conditioning system, the outside air is drawn through a duct and the return air is drawn from indoor space through a return duct or through the plenum above the drop ceiling. The outside air and return air is mixed in the mixing chamber of AHU in right proportion, filtered, heated or cooled, and delivered to occupied areas via supply air ducts. The conditioned air is finally discharged into the space through supply air diffusers located on the drop.

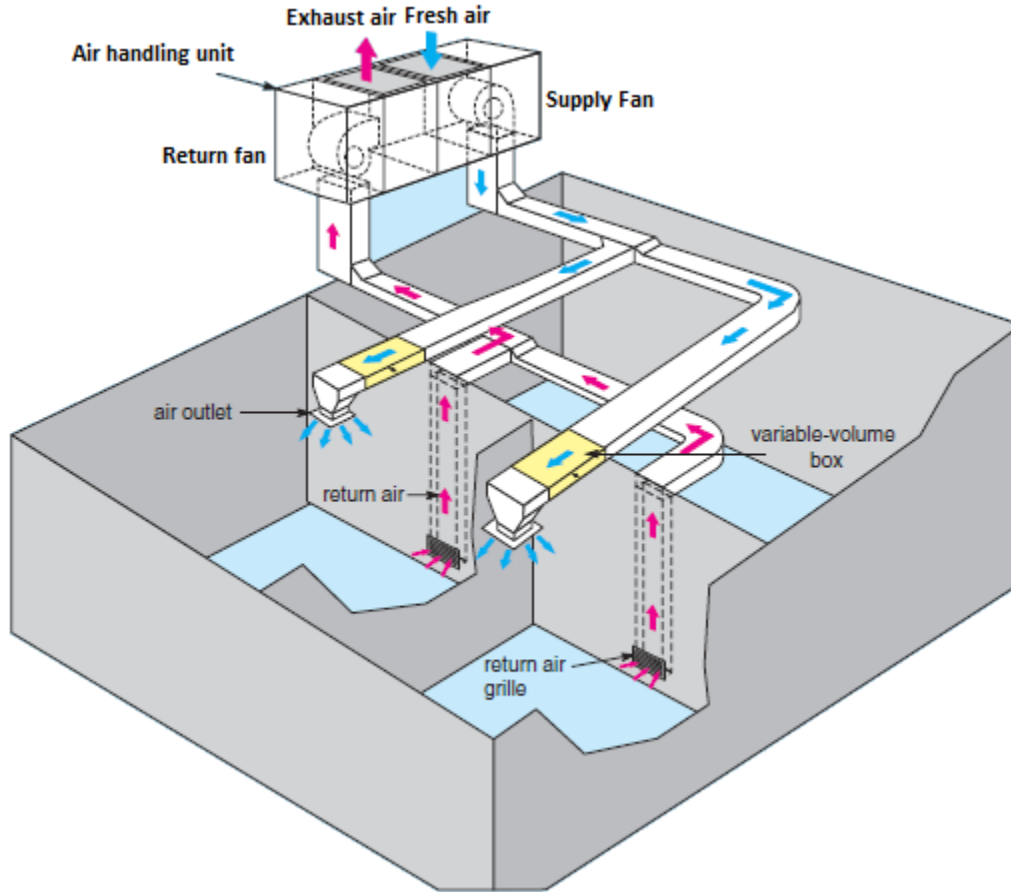

A duct system is also called ductwork. Ducts should be designed to meet the Standards listed in the ACCA Manual D Residential Duct Systems or SMACNA standards.

Ducts can be made out of the Galvanized steel, Aluminum, Polyurethane panels, Fiberglass or cloth etc.

Ducts can be fabricated in round, oval or rectangular shapes.

Round ducts provide the maximum air carrying capacity with minimum pressure loss for same air volume. These are usually less expensive to fabricate and install. The drawback however is that these require higher ceiling heights.

Rectangular ducts in aspect ratio of 1:3 are usually preferred for tight ceiling spaces. Higher aspect ratios are not economical and costly to build.

#### **When to provide ducting:**

- A ducted air condition system provides better air circulation and is recommended option for large areas. Since ductless air conditioning systems cool the air in each room individually, there is less air movement throughout the space, sometimes leading to hot or cold spots, stagnant air and air pressure issues.

- Ducted air conditioning systems are better at controlling humidity. The air handlers in ductless air conditioning lack the mechanisms needed to remove much moisture from the air and drain it away.
- Ducted systems are many times used to enhance the aesthetic appeal of interiors. Ductless stems involving use of fan coil boxes mounted on the wall or ceiling are not always ideal from an aesthetic perspective. With a ducted system, everything is hidden behind walls and in crawl spaces.
- Ducted systems ease maintenance. Ducted air conditioning systems will have just have single air handling unit located outside the space and therefore the maintenance activities will be outside the conditioned space. Ductless systems will require multiple fan coil units spread all over the indoor space.
- Sometimes HVAC equipment or conditioned space is located in places where the air is polluted such as garage where cars idle or where some odor causing materials are stored. It is important to take ducted fresh air away from such places.

### **When to choose ductless air conditioning**

- Low height - When the floor-to-floor height is low and there is no room for ducts in the walls or ceilings. Otherwise, also if you want to retain your high ceilings for aesthetic reasons then ductless air conditioning is the answer.
- Zoned cooling - Ductless unit is often used to provide zoned cooling for an area that is not frequently used or is overused. For e.g. in an office complex, the manager room or conference room may be provided with small ductless air conditioning system that can be utilized beyond routine hours.
- Multiple zones - When you want multiple cooling zones. Since ductless air conditioning systems have separate air handlers in each room, these can be independently controlled for different cooling needs. That means you can lower the temperature in the living room where you are entertaining a group of people, while maintaining the comfort temperature in a room where the individual is relaxing.

### **Performance Considerations**

1. Sizing ducts properly is not a matter of guesswork or rule-of-thumb engineering. It is a science. Not Too Small, Not Too Large.
  - Undersized supply ducts cause excess pressure near the air handler. This over-pressure follows the path of least resistance, flooding branches closest to the air handler with conditioned air while more distant branches and rooms are left inadequately cooled or heated. The system responds with shorter on/off cycles, increased energy usage and wear and tear. Undersized return ducts may create pressure imbalances in rooms, leaking heated or cooled air out of the home's thermal envelope through gaps and cracks. Undersized ducts are also noisy and can cause other system problems such as freeze-ups at the A/C evaporator coil or high furnace temperatures.
  - Oversized ducts reduce air velocity, decreasing the discharge rate in rooms and affecting comfort level. Also, there's the needless expense of buying ducts with capacity you don't need, plus additional installation problems and costs due to larger physical size.

2. Location of the air handler. Ideally, the air handler should be situated in a central location relative to the main trunk and branches of ductwork. This helps equalize air flow and makes balancing room air pressures easier.
3. Symmetrical layout. Where possible, ducts that branch off the main trunk to individual rooms should be evenly spaced and of similar length. Combined with equivalent duct sizes, this evens out friction loss and reduces disparities in air flow that results from branches of varying lengths.
4. Room Returns. A return duct in every room is ideal for optimum air balance. For rooms lacking returns, install ceiling jumper ducts to an adjoining room or grilles connecting to a common area with a central return.

### Things to Remember

- Aspect ratio no more than 3:1.
- Allow 3 to 6 sq.-ft. for every 1,000 sq.-ft. of floor space for horizontal and vertical duct runs.
- As air velocity increases noise increases. Increasing air velocity causes more turbulence.

### Recommended and maximum duct velocity ranges

Item	Residences	Public buildings
Fan outlets	1000 – 1700 Fpm	1300 – 2200 Fpm
Main ducts	700 – 1200 Fpm	1000 – 1600 Fpm
Branch ducts	600 – 1000 Fpm	600 – 1300 Fpm
Louvers (Intake/exhaust)	400/500 Fpm	400/500 Fpm
Filters		
Electronic	150-250 Fpm	150-250 Fpm
HEPA	250 Fpm	250 Fpm
Viscous/Pleated	500 Fpm	500 Fpm
Cooling coils (Dehumidifying)	500 Fpm	500 Fpm
Heating coils (steam/water)	500- 800 Fpm	500 – 800 Fpm

- Design toward smaller end of range for quieter systems and toward larger end of range to minimize duct sizes.
- Loss of pressure is due to friction of the air moving through the ducts, fittings, registers, and other components. The design friction rate is generally determined based on the velocity of the air in the first section of ductwork. Most designers use a design friction rate somewhere between 0.08 and 0.10 in. w.g. per 100 ft. equivalent length.

### HEATING SYSTEMS

In a modern heating system, heating can be provided by:

- Electric heaters
- Heat pumps, either liquid or air

- Furnaces, unit heaters, duct heaters, and outside air heaters that provide hot air for direct circulation to the conditioned space
- Fuel-fired boilers that produce steam, hot water, or thermal liquids for direct or indirect use

End users are provided heat by:

- Direct air - furnaces, duct heaters, outside air heaters, reheat units, ducted heat pumps
- Indirect air - coils and air-handling units, fan-coil units, unit ventilators
- Liquid - radiators, convectors, liquid-filled radiant heaters
- Radiation - direct radiation from panels or other radiators

### Electric Space Heaters

Electric space heaters convert electric current from the wall socket directly into heat, like a toaster or clothes iron. It has two principal virtues: it is very convenient to install and low on cost. The control is easy and user can turn down the heat in unoccupied rooms. The operating costs are however high and is seldom recommended for continuous use.

The cost to operate a 1,500-watt unit for an hour is simple to compute: it is 1.5 times your electricity cost in cents per kilowatt-hour. At national average rates—12¢ kWh for electricity— that heater would cost 18¢ per hour to run—and quickly cost more than its purchase price.

### Heat Pumps

A heat pump works much like a conventional air conditioner, except it can also run in reverse during the winter to provide heat. Heat pumps are more efficient because they do not create heat, but merely move — or pump — it from one place to another. These work best in moderate climates.

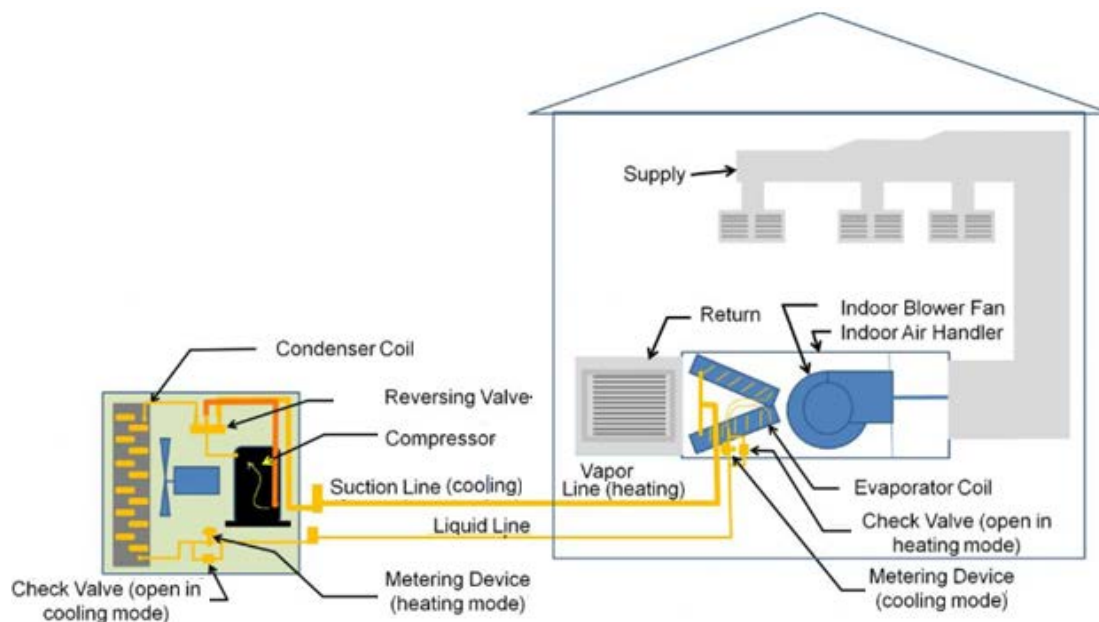



Because electricity in a heat pump is used to move heat rather than to generate it, the heat pump can deliver more energy than it consumes. The ratio of delivered heating energy to consumed energy is called the coefficient of performance, or COP, with typical values ranging from 1.5 to 3.5. This is a “steady-state” measure and not directly comparable to the heating season performance factor (HSPF), a seasonal measure mandated for rating the heating efficiency of air-source heat pumps.

### Gas Fired Furnaces

The gas fired furnaces use natural gas that heat a metal heat exchanger. Air is pushed through the heat exchanger by the “air handler’s” furnace fan and then forced through the ductwork downstream of the heat exchanger. At the furnace, combustion products are vented out of the building through a flue pipe. Older “atmospheric” furnaces vented directly to the atmosphere, and wasted about 30% of the fuel energy just to keep the exhaust hot enough to safely rise through the chimney. Current minimum-efficiency furnaces reduce this waste substantially by using an “inducer” fan to pull the exhaust gases through the heat exchanger and induce draft in the chimney. “Condensing” furnaces are designed to reclaim much of this escaping heat by cooling exhaust gases well below 140°F, where water vapor in the exhaust condenses into water. This is the primary feature of a high-efficiency furnace (or boiler). These typically vent through a sidewall with a plastic pipe.

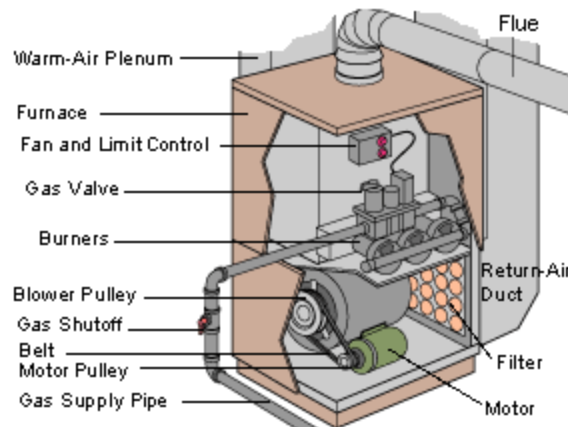

The efficiency of a fossil-fuel furnace or boiler is a measure of the amount of useful heat produced per unit of input energy (fuel). Combustion efficiency is the simplest measure; it is just the system’s efficiency while it is running. Combustion efficiency is like the miles per gallon your car gets cruising along at 55 miles per hour on the highway. In the U.S., furnace efficiency is regulated by minimum AFUE (Annual Fuel Utilization Efficiency). AFUE estimates seasonal efficiency, averaging peak and part-load situations. AFUE accounts for start-up, cool-down, and other operating losses that occur in real operating conditions, and includes an estimate of electricity used by the air handler, inducer fan, and controls. AFUE is like your car mileage between fill-ups, including both highway driving and stop-and-go traffic. The higher the AFUE, the more efficient will be the furnace or boiler.

### Gas Fired Boilers

Boilers are special-purpose water heaters. While furnaces carry heat in warm air, boiler systems distribute the heat in hot water, which gives up heat as it passes through radiators or other terminal

devices. The cooler water then returns to the boiler to be reheated. Boilers can produce low-temperature, medium-temperature, or high-temperature water that can be configured as “all-water” hydronic system discussed earlier.



Commercial boilers generally use natural gas or heating oil for fuel. The following boilers are used with varying combustion efficiencies between 78% and 86%.

- Fire tube steel boilers are constructed so that hot gases from the combustion chamber pass through tubes that are surrounded by water. Typically, fire tube boilers do not exceed 25 million Btu/hr (MMBtu/hr), but capacities up to 70 MMBtu/hr are available.
- Water tube steel boilers pass hot combustion gases over water-filled tubes. Sizes for packaged water tube boilers range from small, low pressure units (e.g., around 10 MMBtu/hr) to very large, high-pressure units with steam outputs of about 300 MMBtu/hr.
- Cast iron boilers are used in small installations (0.35 to 10 MMBtu/hr) where long service life is important. Since these boilers are composed of precast sections, they can be more readily field-assembled than water tube or fire tube boilers. At similar capacities, cast-iron boilers are more expensive than fire tube or water tube boilers.

As with furnaces, condensing gas-fired boilers are more efficient than non-condensing boilers. Condensing boilers achieve higher system efficiencies by extracting so much heat from the flue gases that the moisture in the gas condenses. These are typically fired with natural gas and operate between 95% and 96% combustion efficiencies. Condensing boilers are available in capacities between 0.3 and 2 MMBtu/hr, and can be connected in modular installations.

## INDOOR AIR QUALITY

In buildings with functional air barriers, a health requirement is the provision of fresh air, typically at about 15 to 20 cubic feet per minute (cfm) per person. This provides oxygen (which is a small portion of the air) and dilutes and/or removes pollutants. ASHRAE Standard 62 specifies minimum ventilation rates to provide indoor air quality that is acceptable to human occupants and that minimizes adverse health effects.

Carbon dioxide (CO<sub>2</sub>) is a surrogate for evaluating air quality when ventilation air is the major factor in fresh air changes to the conditioned space.

### Filtration

Air picks up pollutants (dust, pollen, gases, etc.) of all kinds as it moves around a building and as it enters a building from the outside. Hence, it is often desirable to clean the air.

Several methods of filtration are available for use in environmentally controlled systems.

- **Fibrous media filters** are composed of a coarse fiber material such as fiberglass, metal mesh, or vegetable fibers. The air to be filtered is forced through the material where dust and other similarly sized particulates become trapped in the matrix. Depending on the type of fibrous material used, it may be washed or replaced when dust impedes the airflow. As dust is trapped in the filter material, the effectiveness of the filter increases the passageways for the air get smaller, but the pressure drop across the filter also increases, creating a higher demand on the systems blower unit.
- **Electronic Air Cleaners** - By passing air through an electric field typically 12,000 volts, particulates receive a charge. When the charged particulates are subsequently passed through a matrix of oppositely charged plates, the particles are attracted and collected on the plates. The plates may be removed for cleaning or washed in place periodically.
- **High Efficiency Particulate Air (HEPA) Filter** - The high-efficiency particulate air HEPA filter is the most efficient air-cleaning system commercially available. Although it was developed for the nuclear industry, it has been found to be extremely useful in the medical and electrical fields. HEPA filters provide a minimum efficiency of 99.97% on 0.3-micron particulates. A micron is one-millionth of a meter. The filter media is typically a fibrous material with a high surface area to volume ratio. Design velocities are held down to about 5 feet-per-minute. This increases the particulate-holding characteristics of the filter.
- **Activated carbon filters** are commonly used to remove volatile organic compounds, gases and vapors from recirculated air. The process involved is adsorption, where the carbon adsorbs the gases and vapors in a sponge-like process. The carbon will also trap some particulate matter.

The American Society of Heating, Refrigeration and Air-Conditioning Engineers (ASHRAE) recommend specific filter efficiencies (MERV) types of buildings and have assigned values to allow easier selection of the appropriate filter. The following chart notes some common filter applications.

Application	MERV
Light duty residential for coil or heat exchanger protection, light commercial for protection of HVAC and industrial equipment	1 to 4
Superior residential for removal of allergens, light duty commercial, split systems and roof tops	5 to 8
Superior residential for removal of allergens, commercial office buildings and institutional	9 to 11
Superior commercial office buildings, superior institutional, removal of minute particles	12 to 13
General hospital areas, low-level surgical suites, smoke removal, superior commercial buildings	14 to 15
High risk surgical suites, hazardous material capture, clean rooms, HEPA level protection	16 to HEPA

MERV is Minimum Efficiency Reporting Value per ASHRAE 52.2, Method of Testing General Ventilation Air-Cleaning Devices for Removal Efficiency by Particle Size.

### SPECIFIC APPLICATIONS

Each building is different. The size of building, location, use and the choice of aesthetics can have a great effect on the individual criteria.

Type of Building	Usage & Application	Type of HVAC
<p><b>Residential</b></p> <p>Houses, apartment buildings, hotels, and motels</p>	<p>Places providing accommodations for overnight stay</p> <p>Apartment blocks have variable usage schedules and require individual control.</p> <p>They have as many zones as individual apartments.</p>	<p>Small independent residential accommodation for 3 to 5 bedrooms may use the split system, variable refrigerant flow (VRF) systems. Large independent accommodation may use ducted split units.</p> <p>Apartment blocks over three-storeys high can use chilled-water systems with individual fan-coil units.</p> <p>Hotels and motels have variable occupancy. Central systems are usually desired in public areas alone – Lobbies etc. Induction-type terminals or fan-coil units are used in individual rooms.</p> <p>Lobbies to be provided with All-air variable air volume or constant volume (VAV or CAV) systems.</p>
<p><b>Educational</b></p> <p>School, colleges, day care centers</p>	<p>Place to study, transient occupancy.</p>	<p>Campus style building may use central chilled water systems with fan coil units for the classrooms and ducted All-air systems for large areas.</p> <p>Large lecture rooms may use package units.</p>
<p><b>Healthcare</b></p> <p>Hospitals, laboratories, homes for aged, nursing homes</p>	<p>Hospitals need special temperature and humidity control.</p> <p>Operating Theatres do not use re-circulating air.</p>	<p>All-air systems with adequate filtration may be used.</p> <p>Induction terminals are often used in closed wards.</p> <p>Any rooms/labs with foul air should be provided with extraction, so that they remain at negative pressure. This will prevent the foul air from drifting out to any other space.</p>

<p><b>Assembly</b></p> <p>Theatres, Drama Hall, Assembly Halls, Auditorium, Exhibition, Restaurants, Place of worship, Terminal etc.</p>	<p>Places used for people gathering for entertainment, worship, and eating or drinking</p> <p>Large occupancy, usually stationary</p>	<p>Central systems are usually desired in public areas. Open atriums and lobbies may use All-air variable air volume units.</p>
<p><b>Business</b></p> <p>Office, banks, insurance agencies, computer Installations</p>	<p>Places where <i>services</i> are provided</p> <p>Speculative office buildings have shifting tenancy.</p> <p>They typically require many independent zones.</p>	<p>Air-and-water systems called induction-type air terminals may be used in the perimeter zones.</p> <p>All-water fan-coil units can also be used.</p> <p>All-air systems called variable air-volume units can be used for the core inner areas.</p> <p>Large multi-storey building may use central chilled water system.</p> <p>In an office, it is a good idea to provide standalone AC units for conference rooms and executive cabins. These can be used by people working late or on weekends, when the main AC system is off.</p>
<p><b>Mercantile</b></p> <p>Shopping malls, grocery stores, department stores etc.</p>	<p>Places where goods are displayed and sold.</p> <p>Shopping Centers have transient occupancy.</p>	<p>Air distribution is less critical because shoppers are moving about.</p> <p>Medium sized department stores may use roof top unit installation with variable air volume units.</p> <p>Large shopping malls may use all-water fan-coil units in individual stores. This enables individual temperature control as well energy metering.</p> <p>Large open atriums and lobbies may use All-air variable air volume units.</p>
<p><b>Industrial</b></p> <p>Factories, assembly plants, pumping stations etc.</p>	<p>Places where goods are manufactured or repaired.</p>	<p>Factories generating significant heat loads may rely on mechanical ventilation alone, if the temperature/humidity conditions are not stringent.</p> <p>Semiconductors and electronic industries may use clean room All-air</p>

		<p>air-conditioning system with High efficiency particulate arrestance (HEPA) filters.</p> <p>Places involving production or storage of very flammable or toxic materials should rely on exhaust ventilation. Control on air pressurization is important depending on the application.</p>
--	--	--

\*\*\*\*\*

## CHAPTER - 4 FIRE FIGHTING SYSTEMS

A firefighting system is probably the most important and often the mandatory building service aimed to protect human life and property, strictly in that order. It consists of three basic parts:

- A large store of water
- A specialized pumping system
- A large network of pipes connected to hydrants and/or sprinklers

In US and many other parts of the world, the design parameters are set in accordance with National Fire Protection Association (NFPA) standards. These are the minimum requirements. Fire protection systems designers must also adhere to local rules and the insurance rating agency (Factory Mutual, Industrial Risk Insurer etc.) requirements beyond the minimum standard required by NFPA.

### THE DIFFERENCE BETWEEN CODES AND STANDARDS

#### Code

Codes specify circumstances WHEN and WHERE a given type of protection is required. Codes are MINIMUM requirements; they can and are encouraged to be exceeded.

#### Examples of Codes:

- NFPA 30 Flammable and Combustible Liquids Code
- NFPA 54 National Fuel Gas Code
- NFPA 70 National Electrical Code
- NFPA 101 Life Safety Code
- NFPA 5000 Building Construction and Safety Code
- IBC International Building Codes

#### Standard

Standards detail HOW the protection required by the code is to be achieved.

#### Examples of Standards:

- NFPA 10 Standard for Portable Fire Extinguishers
- NFPA 13 Standard for the Installation of Sprinkler Systems
- NFPA 14 Standard for the Installation of Standpipes and Hose Systems
- NFPA 20 Standard for the Installation of Stationary Pumps for Fire Protection
- NFPA 72 National Fire Alarm Code (This is actually a standard even though it is called a code)
- NFPA 72 will explain how a fire alarm system is supposed to be installed. It does not determine what type of equipment such as smoke detectors, pull stations, horns, strobes, etc. should be used. That is determined by the adopted building code.

The terms “Shall” and “Should” are often used.

“Shall” Indicates a mandatory requirement.

“Should” Indicates a recommendation.

## **FIREWATER DEMAND**

Water is used to suppress most fires. The firewater demand is the rate and amount of water the fire service will need to extinguish the fire. This will decide the on-site firewater storage volume and the capacity of fire pumps.

The firewater demand/fire water pumps capacity is decided by considering a number of factors:

- The area covered by hydrants/standpipes and sprinklers
- The number of hydrants and sprinklers
- The assumed area of operation of the sprinklers
- The type and layout of the building

NFPA codes and installation standards specify the criteria to determine the water supply needs for hydrants, sprinklers and/or standpipes.

Three important parameters that require calculation include:

- determining the minimum fire water flow rate (gallons per minute, or GPM)
- total quantity of water storage (gallons)
- capacity and pressure of fire pumps (pounds per square inch, or psi)

## **FIRE WATER STORAGE TANKS**

Most building codes require a dedicated “on-site” water storage tank, pump, and suppression system for large public buildings and commercial offices. The amount (volume) of water is determined by the hazard level of the building. Most building codes specify three levels, namely:

- Light Hazard (such as schools, residential buildings and offices)
- Ordinary Hazard (such as most factories and warehouses)
- High Hazard (places which store or use flammable materials like foam factories, aircraft hangars, paint factories, fireworks factories).

The relevant building code lists which type of structure falls in each category.

The storage capacity is determined by duration of an expected incident in terms of time multiplied by the required water flow demand or pumping capacity. For example, if the fire water demand is 1,500 GPM, the useable fire water storage volume for 1 hour shall be  $1,500 \times 60 \text{ minutes} = 90,000$  gallons).

The main code that governs design and installation of fire storage tank in North America is the National Fire Protection Association's NFPA 22: Standard for Water Tanks for Private Fire Protection.



These tanks are separate from the tanks used to supply water to occupants, which are usually called domestic water tanks. It is also possible to have a system in which the firefighting and the domestic water are in a common tank. In this case, the outlets to the fire pumps are located at the bottom of the tank and the outlets to the domestic pumps must be located at a sufficient height from the tank floor to ensure that the full quantity of water required for firefighting purposes is never drained away by the domestic pumps.

## FIRE PUMPS

Fire pumps are used to boost the water pressure to sprinkler and standpipe systems. A fire pump may be driven by an electric motor or a diesel engine.



An electric fire pump located in a fire-fighting pump room

Fire pumps are usually housed in a pump room very close to the fire tanks. The key thing is that the pumps should be located at a level just below the bottom of the fire tank, so that all the water in the tanks can flow into the pumps by gravity.

Like all-important systems, there must be backup pumps in case the main pump fails. There is a main pump that is electric and a second backup pump that is diesel-powered. Each of these pumps is capable of pumping the required amount of water individually; they are identical in capacity.

There is also a third type of pump called a jockey pump. This is a small pump, which continually switches ON OFF to maintain the correct pressure in the distribution system. The water pressure is normally 100 to 120 psig. If there is a small leakage somewhere in the system, the jockey pump will switch ON to compensate for it.

The pumps are controlled by pressure sensors. When a fire fighter opens a hydrant, or when a sprinkler comes on, water gushes out of the system and the pressure drops. The pressure sensors will detect this drop and triggers the fire pumps ON. Once the main pump is ON, it has to be switched OFF manually per most codes.

The main code that governs fire pump installations in North America is the National Fire Protection Association's NFPA 20 Standard for the Installation of Stationary Fire Pumps for Fire Protection.

A fire pump is tested and listed for its use specifically for fire service by a third party testing and listing agency, such as UL or FM Global.

## THE DISTRIBUTION SYSTEM

There are two types of distribution systems

- Wet systems: those are filled with water and pressurized. The drop in pressure will trigger the pump ON.
- Dry systems: those are filled with pressurized air instead of water. A drop in air pressure will trigger the fire pump ON. This system is applied where there is a risk of the fire pipes freezing due to low ambient temperatures.

## GENERAL FIRE FIGHTING EQUIPMENT

Firefighting systems and equipment vary depending on the age, size, use and type of building construction. A building may contain some or all of the following features:

- Fire hydrant systems
- Fire hose reels/standpipe systems
- Automatic sprinkler systems
- Fire extinguishers

### Fire Hydrants

A fire hydrant is a vertical steel pipe barrel with one or more 2½ inch outlet nozzles for hose connection. During a fire, firefighters will attach the hose to the outlet nozzle, and manually open the hydrant valve. Since the network is pressurized, the water will gush out and the drop in pressure will trigger the fire pump ON.

Two types of hydrants are common:

- Wet barrel hydrants are used in warm climates. Water remains in the barrel of the hydrant at all times. Each hose outlet is individually valved, and can therefore be operated one at a time.
- Dry barrel hydrants are used in climates subject to freezing. A valve below the frost line is activated by an operating nut on the top. When the valve is opened, water fills the hydrant body (or barrel) above it.



Wet barrel hydrant (warm climates)



Dry barrel hydrant (freezing temperatures)

Typically, hydrants have a large hose outlet (4½ inches is a common size) called a pumper outlet or steamer connection. They normally also have one or more 2½ inch hose outlets.

The maximum distance between hydrants (typically addressed in fire codes) determines how much hose will be needed to reach a fire. Pumpers carry a limited amount of hose. Some standard rules of thumb for spacing are 250 feet in commercial centers and 500 feet in residential clusters.

### Standpipe Systems

In high-rise buildings, it is mandatory that each staircase has a wet riser, a vertical firefighting pipe and a hydrant at every floor.

The installation standard for standpipe systems is NFPA 14, Standard for the Installation of Standpipe and Hose Systems. This standard allows options for FHCs, valves, and other design features. Standpipe systems are often combined with sprinkler systems.

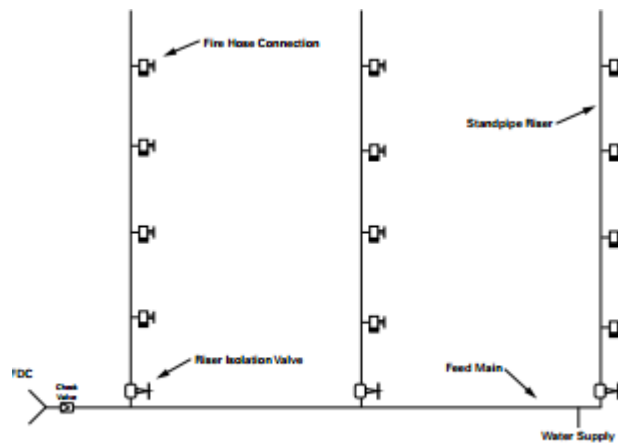

A schematic diagram of a standpipe system

Standpipe systems are classified according to usage:

**Class I Standpipe: used by fire departments only**

- Equipped with 2.5" outlets and hoses for fire department use only;
- Located at every level of a building within stairway enclosures or within the vestibule if exit enclosure is pressurized;
- Must be used when any portion of a building interior is more than 200 feet of travel from the nearest point of fire department access;
- Used in buildings with more than three stories, and shopping malls; and
- If more than 75' above grade, the pipe connection must be provided in every required stairway as well.

**Class II Standpipe: used by occupants before the fire department arrives**

- Equipped with 1.5" outlets and hoses for occupant use;
- Required in buildings 4 or more stories tall, theaters and assembly spaces;
- Every point of the building must be within 30' of the end of a 100' hose attached to an outlet; and
- Water system must be designed to provide 70 gallons per minute (gpm) at 25 psi for 30 minutes.

**Class III Combination Standpipe: used by both occupants and fire departments**

- A combo system directly connected to a water supply with both 1.5" and 2.5" outlets;
- Installed in buildings where the highest floor level is more than 30' above the lowest level of the fire department access;
- Every point of the building must be within 30' of the end of a 100' hose attached to an outlet; and
- Installed in buildings where the highest floor level is over 30' above the lowest the fire department vehicle access, or where the lowest floor level is 30' below the highest fire department vehicle access.

**Sprinkler Systems**

Sprinklers are the most widely specified suppression system in commercial facilities, particularly in occupied spaces. The whole philosophy of sprinklers is based upon the premise of applying the right amount of water (as little as possible) in the right place (the seat of the fire) at the right time (as quickly as possible).

The basic components of a sprinkler system are the sprinklers, system piping, and a dependable water source. Most systems also require an alarm, system control valves, and means to test the equipment.

The sprinkler itself is a spray nozzle, which distributes water over a defined fire hazard area (typically 150–225 ft<sup>2</sup>) by actuation of its own temperature linkage. There are two main types of sprinklers. Closed sprinklers have a heat-activated element made of either a glass bulb or a fusible metal link that bursts or melts at a specified temperature. Open sprinklers do not have this heat activated element and will discharge water as soon as it is available to the sprinkler system.

Open systems require a separate fire detection system to release the water into the system piping. The installation standard for sprinkler systems is NFPA 13, “the Standard for the Installation of Sprinkler Systems”.

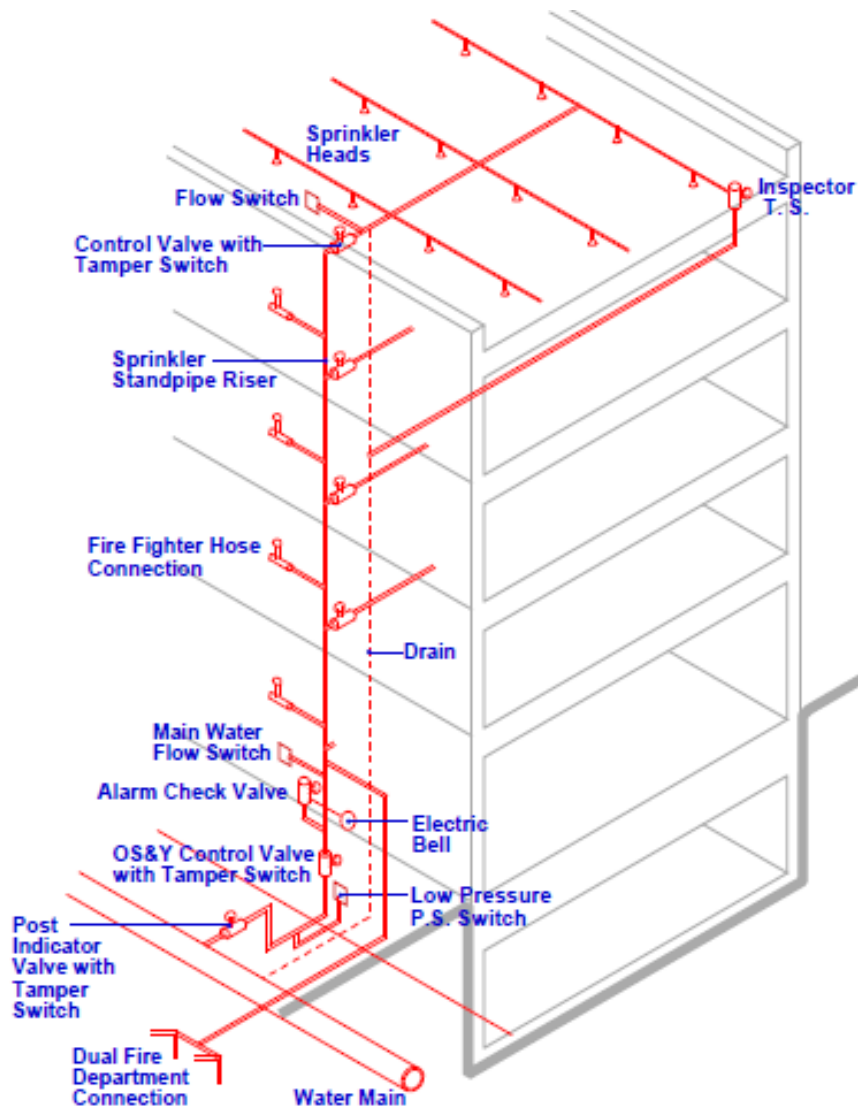

## Types of Sprinkler Systems

There are five basic sprinkler system types. Each system has distinctive operating characteristics that should be addressed by the end user.

1. **Wet sprinkler system:** The piping in a wet system is filled with pressurized water. Closed sprinklers open when activated by heat and immediately discharge water. Wet sprinkler systems are the most common type of system. They should not be used in areas where the temperature may fall below 40°F.
2. **Dry sprinkler system:** The piping in a dry system is filled with pressurized air or nitrogen, instead of water. Once enough heat is generated to activate one or more sprinklers, the air is released from the system through the sprinklers. At a predetermined pressure, a dry

pipe valve automatically opens and releases water to the open sprinklers. There is a nominal delay between the opening of the dry pipe valve and the water discharge from the sprinklers, as the air within the sprinkler piping is released. Dry systems are used to protect areas subject to freezing, such as unheated warehouses, loading docks and attic spaces.

3. **Pre-action sprinkler system:** Similar to a dry system, the piping in a pre-action system may or may not contain the pressurized air. Water from the supply piping is held back by a pre-action valve and is released to the system piping when the fire detection system and/or sprinklers (depending on the type of pre-action system) is activated. Pre-action systems prevent false sprinkler activation and reduce the likelihood of accidental water discharge. These are generally applied to protect high-value electronic equipment in areas such as computer rooms.
  
4. **Deluge system:** Uses open sprinklers to deliver a large quantity of water over a specified area in a short period. A deluge valve is activated by a fire detection system installed in the same area as the sprinklers. When the deluge valve opens, water flows into the system and discharges from all the attached sprinklers in the system. Deluge systems are used to protect flammable liquid storage, lumberyards, large airplane hangars and electrical transformers.

## FIRE EXTINGUISHERS

Most fires start as a small fire and may be extinguished if the correct type and amount of extinguishing agent is applied while the fire is small and controllable.

The principle fire extinguisher types commonly used include:

Classification	Extinguishing Agent	Principle Use
Type A	Water	wood and paper fires - not electrical
Type B	Foam	flammable liquid fires - not electrical
Type C	Carbon dioxide	electrical fires
Type ABC	Dry Chemical	flammable liquids and electrical fires
Type K	Wet chemical	fat fires - not electrical
Type D	Special Purpose	Suitable for combustible metals

NFPA 10 lists the advantages and common uses of each type. It includes tables [3-2.1 and 3-3.1 in 1988 Edition] of maximum travel distances to extinguishers, which must be used to determine extinguisher spacing and locations. Maximum travel distances typically range from 30 feet to 75 feet depending on the type of Hazard Occupancy and type and size of extinguisher.

NFPA 10 includes tables of maximum floor areas per each extinguisher [Table E-3-4 in 1988 Edition]. For example, a typical 4-A rated extinguisher can cover 6,000 square feet in Ordinary Hazard Occupancy.

\*\*\*\*\*

## CHAPTER – 5 FIRE ALARM SYSTEMS

A fire alarm system is distinct from a firefighting system; the two are independent.

A key aspect of fire detection and alarm is to identify a developing fire emergency in a timely manner, and to alert the building's occupants and fire emergency organizations. Depending on the anticipated fire scenario, building and use type, number and type of occupants and criticality of contents and mission, these systems can provide several main functions:

- Activate the fire suppression system and/or notify occupants of abnormal or harmful conditions;
- Integrate with security systems and appropriate entities (such as the fire service, building fire wardens, staff responders, maintenance personnel, etc.);
- Control auxiliary building fire safety devices, emergency lighting, elevator capture and other systems to enhance life safety (related to air handling units, egress door locks, fire doors, fire dampers, etc.); and
- Provide intelligence to responding firefighters regarding the occupants, the fire location, smoke movement, and the status of the installed fire protection systems and devices.

### DETERMINING FIRE ALARM REQUIREMENTS

The trigger to install a fire alarm system is NFPA 101 Life Safety Code, which is based on the occupancy classification of the building. The installation standard for fire alarm systems is NFPA 72, National Fire Alarm Code. This code, along with the fire alarm wiring portion of NFPA 70, the National Electrical Code, contains comprehensive requirements for the design, installation, and maintenance of fire alarm and detection systems.

### Design Features

Systems vary widely in complexity. A basic system consists of the following components:

1. A fire alarm control panel (FACP) is a control and indication equipment, which displays any alarms and the system status, monitor the system for faults and have controls to silence and reset the system. The standard governing fire alarm control panels is ANSI/UL Standard 864.
2. A primary operating power supply (120 VAC).
3. A secondary power supply (usually a battery). This is most often a rechargeable storage battery and dry cells are not permitted.
4. Input devices are the alarm initiating devices comprising of manual call points, automatic heat or smoke detectors, pressure switches, water level/flow switch activated by a sprinkler system, tamper switches etc. These devices are located in one area, or zone, so an alarm condition in this zone can direct firefighting personnel to the source of the alarm. Typically, a zone usually consists of a floor of a small building, or wing of a larger building, etc. with area limitations defined in the National Fire Alarm Code (NFPA 72).
5. Output devices include horn, bell, hooters and/or sounders and are used to sound the alarm. This may include flashing lights, annunciators and other visual notification devices to indicate the location and type of alarm. This assists firefighters with their initial response. Outputs also include trouble or supervisory signals that typically notify maintenance personnel or others responsible for correcting abnormal conditions.

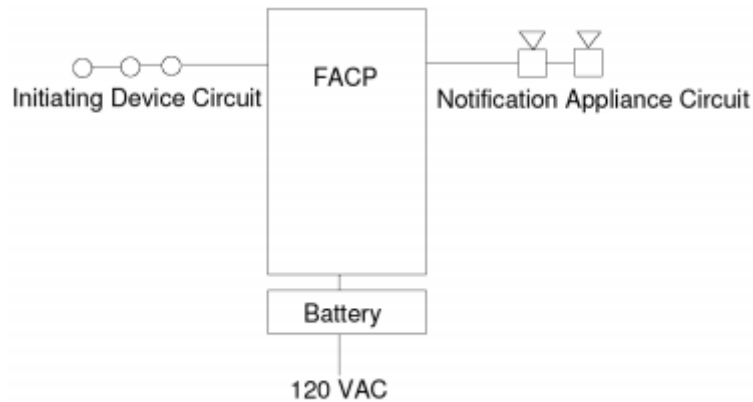

Basic Conventional Fire Alarm System

## CONTROL PANELS

The fire alarm control panel (FACP) is the "brain" of the fire detection and alarm system. It is responsible for monitoring the various alarm "input" devices and then activating alarm "output" devices. The function of a fire alarm control panel is threefold:

- Accept an alarm or supervisory input from an initiating device;
- Provide an alarm output to the notification appliance(s); and
- Monitor the integrity of the panel itself and the wiring to the above devices.

In addition, the system performs various other auxiliary building fire safety functions such as elevator recall, ventilation system shutdown, smoke control activation, fire door or damper closure, and stair door unlocking.

Modern systems use "addressable" type fire detection and alarm technology. Addressable fire alarm systems assign each initiating device a discrete and unique identification (address). In addition to the address, the panel will usually have the ability to have a tag to further identify the address (i.e. Address 1, Front Lobby, back door, hallway, etc). Some addressable systems consider each point as a separate zone. Addressable devices are similar to conventional devices in that they are either in alarm or in a normal condition. Advantages provided by addressable alarm systems include stability, enhanced maintenance, and ease of modification.

## FIRE ALARM SIGNALS

The fire alarm system recognizes four different states or conditions: normal, alarm, trouble and supervisory.

### Normal

Status showing an operationally ready mode. Status indicators give information about the condition of devices external to the alarm system. Examples include:

- Main system power on
- Main system trouble
- Fire pump running



- Fire pump fault
- Fire pump phase reversal
- Generator run
- Generator fault
- Stair doors unlocked
- Smoke control system in operation
- Elevator floor status

Controls and monitors for ancillary functions are routinely included on alarm panels or annunciators. These include:

- Fire pump start switches and indicators
- Generator start switches and indicators
- Egress or stair door unlocking switches
- Smoke control or smoke ventilation switches

### Alarm

A signal indicating an emergency that requires immediate action, such as a signal indicative of a fire.

- Automatic water flow device
- Manual fire alarm station (pull station)
- Automatic fire detectors (smoke or heat detectors)

### Supervisory

A supervised system (sometimes referred to as a “closed circuit” system) will create a trouble signal in the event of a break in the field wiring, disconnection or removal of an initiating device or notification appliance, failure of main operating power, disconnection of the standby battery, or off-normal position of a panel switch. A trouble condition will light one or more yellow LEDs on the panel and cause an audible signal, (usually a piezoelectric device) to sound. The audible signal can be silenced by operating the ‘Trouble Silence’ switch on the panel. Since the panel is locked, the trouble sounder can only be silenced by authorized personnel who have access to the key.

In a conventional system, supervision is made possible by use of an ‘End of Line’ (EOL) device, usually a resistor, although other components may be used, depending on the designer.

### Trouble

A signal indicating a problem with the fire control panel or associated wiring which may render the system inoperable.

- Loss of primary power (120VAC)
- Loss of secondary power (battery)
- A break in the supervised wiring to an initiating device, indicating appliance or extinguishing agent release device

An unwanted nuisance alarm may result for example from improperly located smoke detectors. Locations likely to cause problems include those close to kitchens, air diffusers, and fans, as well as within elevator hoistways.

Note: Devices subject to frequent unwanted alarms (primarily smoke detectors in air ducts, air plenums, and elevator hoistways) are often arranged to activate a supervisory signal, since their main purpose is mechanical control rather than initiating occupant evacuation.

Some smoke detectors have an adjustable sensitivity feature that can help prevent unwanted alarms. Sensitivity should be set very low for areas such as mechanical spaces and low for corridors and elevator lobbies. Sensitivity can be set high in rooms where the climate is highly controlled, especially if they contain high-value contents such as computer rooms.

## **FIRE COMMAND CENTERS**

High-rise buildings often have a dedicated room or other location-containing fire alarm and related fire protection and utility control equipment. Building and fire codes mandate these for newer high-rises. NFPA 72 refers to them as Fire Command Centers; other terms used include Central Control Station, Emergency Command Center, and Fire Control Room. Fire command centers provide a single location for all equipment that incident commanders would need during an emergency incident.

## **SYSTEM POWER**

Since fire alarm systems are used as a life safety and property protection systems, they must be designed and installed with a high level of reliability. The core concept behind the reliability of a fire alarm system is based on monitoring for the integrity of the circuits. This is achieved by the fire alarm control unit supervising each zone, circuit or point. This is accomplished by end of line resistors, end of line relays and two way communications between the panel and devices throughout the building.

The power system must be robust. Power for the entire fire alarm system shall be provided by power system containing backup batteries with 24-hour capacity. There shall be a minimum of a 20 percent safety factor. The power supply unit shall provide signals for charger failure, overcharge, and common trouble.

Controlled access doors on all levels shall be released upon activation of the fire alarm system.

## **COMMISSIONING AND TESTING**

All fire alarm systems shall be UL certified.

- Use NFPA 24 for underground water mains
- Use NFPA 20 for fire pumps
- Use NFPA 13 for building sprinkler systems
- Use ANSI A17.1 for Elevator Recall
- Use NFPA 110 for Emergency & standby electrical systems
- Follow NFPA 241 during construction.

## CHAPTER – 6 VERTICAL TRANSPORTATION

Vertical transportation systems can be separated into three categories: elevators, escalators, and material movers. Elevators and escalators are commonly referred to as "people movers".

### ELEVATORS

Elevators are usually the primary people movers in tall buildings. An elevator system that is referred to as "single deck" is one that has one elevator per vertical shaft. A "double deck" has two elevator cars existing in the same elevator shaft, one atop the other.

A local elevator can stop at any floor; while an express will skip a certain number of floors, then over a certain range behave as a local. The sky-lobby concept is a shuttle elevator that goes from ground level to a lobby, where local elevators are available for access to other levels.

Primarily they are of two types: Traction and Hydraulic.

- Traction elevators are lifted by ropes, which pass over a hoist attached to an electric motor above the elevator shaft. They are used for mid and high-rise applications and have much higher travel speeds than hydraulic elevators.
- Hydraulic elevators are raised by a plunger or ram. It works by forcing pressurized oil through a valve into a steel cylinder. The pressure forces a piston to rise, lifting the elevator platform and car enclosure mounted on it. The car is lowered by opening the valve and allowing the weight of the car to force oil from the cylinder in a controlled manner. When the valve is closed the car is stopped. Since the weight of hydraulic elevator cars is borne by the piston, there is no need for a structural framework or load-bearing rails. Hydraulic elevators are commonly found in low-rise buildings with two to five floors.

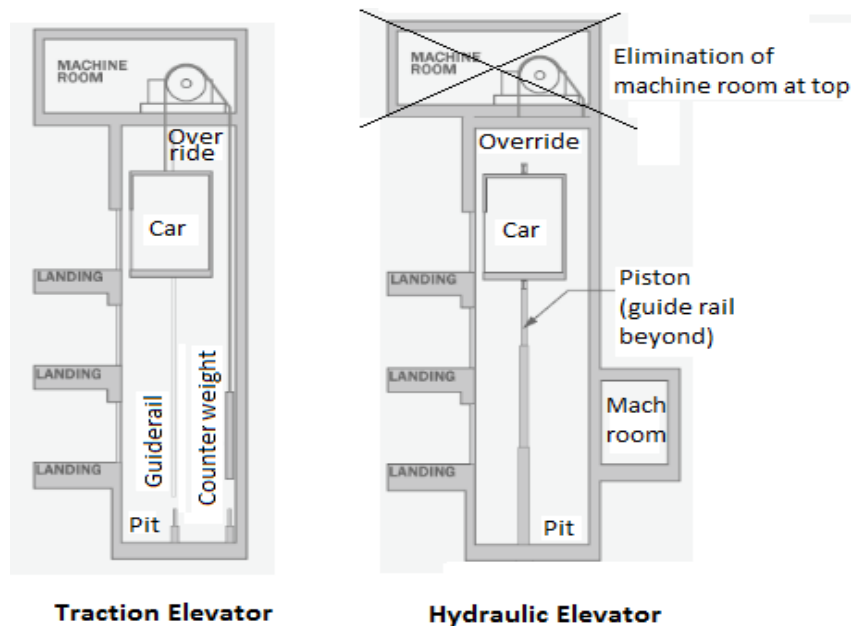

## Hydraulic Elevator

- The main advantage of a hydraulic elevator is it does not require a penthouse machine room or heavily braced roof over the shaft. The machine room is located adjacent to the lift well in either of the floors.
- These are recommended for low-rise buildings up to 5 levels or about 50'-0".
- Speed varies between 25 - 150 feet per minute.
- It is cheaper than the electric elevators. For a given application, the traction elevator will cost approximately twice that of hydraulic equipment.
- A hydraulic elevator imposes no vertical loads on the building structure; column sizes can be reduced significantly in the hoistway area.
- Since the only mechanical connections between the machine room and the hoistway of hydraulic elevators are pipe and conduit, the machine room location can be very flexible, usually anywhere within a radius of 40 feet from the hoistway.

The hydraulic elevator does have some limitations:

- Because of control, power requirement and structural considerations, the conventional hydraulic elevator is seldom applicable for speeds exceeding 150 feet per minute or for travels over 50 feet.
- Performance of hydraulic elevators becomes erratic as the oil in the hydraulic system varies in temperature. The machine room operating temperatures must be controlled.
- The hydraulic elevator has no safety device to prevent its falling. It depends wholly on the pressure in the hydraulic system to maintain its position in the hoistway.
- The motor horsepower required for hydraulic elevators is from 2.5 to 3 times greater than that required for traction elevators of the same speed and capacity.

## Electric (Traction) Elevator

- Traction elevators are recommended where total travel exceeds 50 feet and where speed of travel is a high priority.
- The machine room is located directly above in line with the lift well.
- These are suitable for high volume applications.
- They can speed up to 1,800 feet per minute.
- Their capacities are up to 10,000 pounds.
- **Traction machine:** Motor and drum assembly that is geared or gearless.
  - Geared traction elevators are capable of travel speeds up to 500 feet per minute. The maximum travel distance for a geared traction elevator is around 250 feet.
  - Gear-less traction elevators are capable of speeds up to 2,000 feet per minute and they have a maximum travel distance of around 2,000 feet so they are the only choice for high-rise applications.
- **Roping:** Roping is the arrangement of cables supporting the elevator.
  - **Single wrap:** simplest, cables pass only once over elevator machine sheave and then connected to the counterweight.
  - **Double wrap:** cables pass over the sheave twice, get worn out faster, used for high speed elevators where more traction is required.
  - **1:1 Roping:** when the rope is directly connected to the counterweight, the cable travels in the opposite direction as far as the car

- **1:2 Roping:** when the rope is wrapped around a sheave on the counterweight and connected to the top of the shaft, the rope moves twice as fast as the car, but requires less weight to be lifted.

### Elevator Speed

- Electric Traction Elevators Passenger/Service Minimum: 200 ft./min., Maximum: 350 ft./min.
- Electric Traction Elevator Freight Minimum: 200 ft./min., Maximum: 350 ft./min.
- Hydraulic Passenger Minimum: 100 ft./min., Maximum: 150 ft./min.
- Roped Hydraulic Minimum: 100 ft./min., Maximum: 150 ft./min.
- Hydraulic Freight, Minimum: 100 ft./min., Maximum: 150 ft./min.

Speeds of elevators given the building height and usage type:

Building Height	Small	Average	Prestige	Service
2 - 5 floors	200 - 250 ft./min.	300 - 350 ft./min.	350 - 400 ft./min.	200 ft./min.
5 -10 floors	300 - 350 ft./min.	350 - 500 ft./min.	500 ft./min.	300 ft./min.
10 - 15 floors	500 ft./min.	500-700 ft./min.	700 ft./min.	350-500 ft./min.
15 - 25 floors	700 ft./min.	800 ft./min.	800 ft./min.	500 ft./min.
Over 60 floor	--	--	1,800 ft./min.	1,000 ft./min.

### Typical Elevator Capacities

Elevator capacities depend on the type of building, the size of building, and the weight of people riding.

#### Capacity

- Varies depending on their use and thigh and overall quality of the project
- Small office buildings have an elevator rated about 2,500 lb. Capacity with a floor area of 5'-0" x 7'-0" and a 3'-6" wide center opening door
- Rarely exceed 4,000 lb. capacity for just moving people
- Handling capacity is based on its car size and its round trip time
- People need about 2 square feet of space to feel comfortable

Building Type	Small	Average	Large	Service
Offices	2500/3000 lbm	3000/3500 lbm	3500/4000 lbm	4000/6500 lbm
Garages	2500 lbm	3000 lbm	3500 lbm	-
Retail	3500 lbm	3500 lbm	4000 lbm	4000/8000 lbm
Hotels	3000 lbm	3500 lbm	3500 lbm	4000 lbm
Apartments	2000/2500 lbm	2500 lbm	2500 lbm	4000 lbm
Dorms	3000 lbm	3000 lbm	3000 lbm	4000 lbm
Senior citizens	2500 lbm	2500 lbm	2500 lbm	4000 lbm

## Requirements of Regulatory Agencies

The elevator systems shall be installed in accordance to the National Electrical Code, and the American Society Mechanical Engineering Code for Elevators, ASME A-17.1. It should conform to the Americans with Disabilities Act (ADA) accessibility guidelines, local state regulations and with U-M Barrier Free Elevator Guidelines.

## ADA Requirements for Elevators

Signal Height = 72" min

Signal Size = 2 1/2" min Self

Leveling = within 1/2" of floor landing

Car Controls = 15" min - 48" max

The new American Disabilities Act accessibility guidelines requires that emergency power be available to elevators that have Four (4) or more stories of travel above or below the accessible floor.

## ESCALATORS

Escalators are used to move large numbers of people quickly, efficiently, safely, and at a low cost of operation (4,000 - 8,000 people per hour).

- Made of custom built steel trusses and fitted with belts, steps, and handrails.
- Typical angle of incline is 30°.
- Are typically 32" or 48" wide, with tread widths are 24" or 40".
- Rated by Speed and Size:
  - 100 fpm is the industry standard
  - 120 fpm for transportation and sports facilities

## Types of Escalator Configurations

Escalators are categorized by the relative arrangement, either parallel or crisscross.

- Parallel: up and down escalators "side by side or separated by a distance". This arrangement is more impressive in appearance and seen often in metro stations and multilevel motion picture theaters.
- Crisscross: minimizes structural space requirements by "stacking" escalators that go in one direction, frequently used in department stores or shopping centers.
- A designer seeking to avoid the resentment and confusion of building occupants would design a separation between escalators in a crisscross walk-around of no more than 10 ft.

\*\*\*\*\*

## CHAPTER - 7 PLUMBING SYSTEMS

The plumbing system consists of three major categories: gravity drained waste systems, pressure driven systems, and pumped waste.

- The gravity drain systems include sloped lines, which must have a natural grade line. In addition, the gravity-drained systems require vent lines for the entire system, to allow for open channel flow in the drainage network. Gravity design in many organizations falls in scope of civil department.
- The pressure driven systems include hot and cold water supply lines in various locations in the building. This is a MEP scope.
- Lastly, pumped waste systems include all waste lines that must be driven by pressure rather than by gravity. All pumped waste systems must run in double contained piping systems. This is a MEP scope.

Plumbing design must meet the requirements of Uniform Plumbing Code (UPC).

### PLUMBING SYSTEM

The primary purpose of the plumbing system is to provide adequate water pressure at all times in all parts of the building. This entails delivering the water at the correct pressure at all locations and handling the discharge.

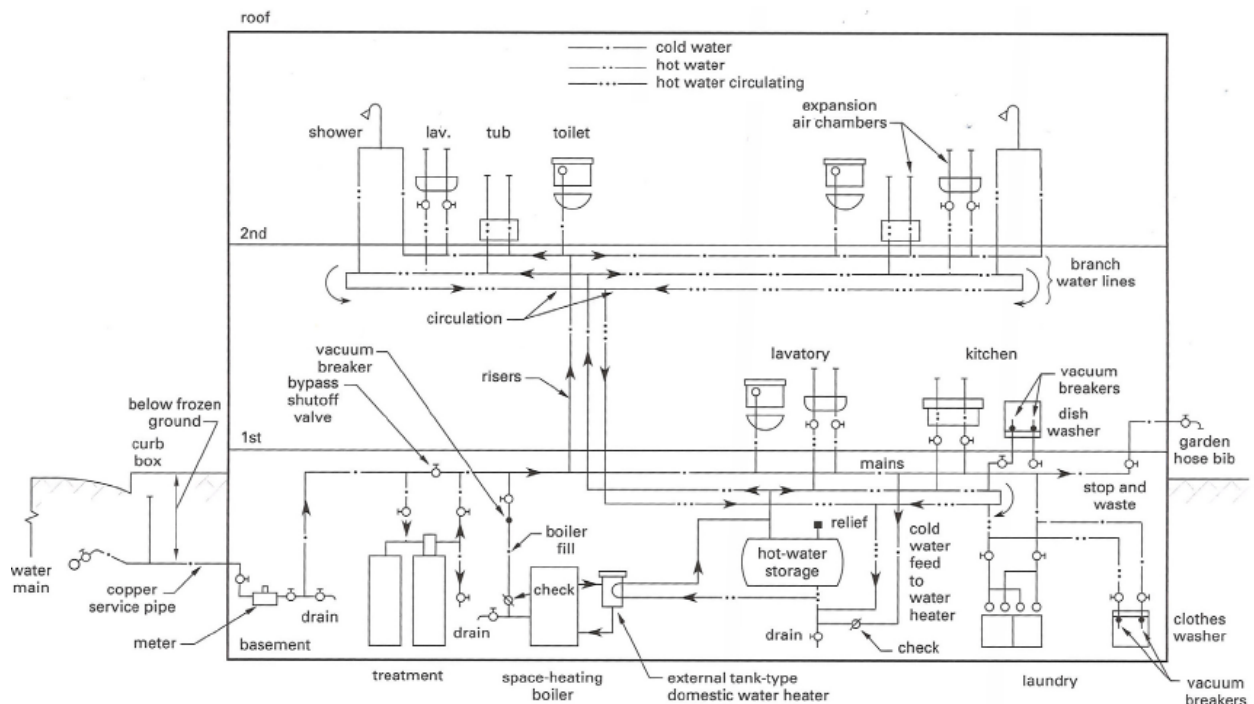

**Plumbing Water Supply Schematic**

The classification of plumbing systems can be separated into four categories: the gravity tank system, the hydro-pneumatic tank system, the booster pump system, or a combination of the above three.

### **Gravity Tank System**

The gravity tank system consists of an elevated tank of adequate capacity with single speed pumps to raise the water to fill the tank. When the water level in the tank drops to a predetermined level, the pumps bring water up until the tank is full.

The overhead tank can be eliminated using a hydro-pneumatic boosting pump.

### **Hydro-pneumatic Tank System**

The hydro-pneumatic system also known as pressure tanks uses compressed air to achieve the desired pressure in the line. Smaller hydro-pneumatic system consists of an automatic pressure controlled pump and a tank, which contains an air filled poly-ether-urethane (PEU) bladder.

### **Booster Pump System**

The booster pump system consists of multiple staged pumps or variable speed pumps that draw water directly from a gravity storage tank or the public water main. The variable speed pump system varies the speed of continuously running pumps to hold a constant discharge pressure under varying flow conditions.

## **PIPING ARRANGEMENT**

Multi-storey buildings can usually be divided into zones of water pressure control. The lower two to three stories can generally be supplied directly from the pressure in the public water main.

Upper stories, usually in groups of five to eight stories, can be supplied from pressure-boosted main risers through a pressure reduction valve for each group. Systems can be up-fed or down-fed.

- Up-fed systems usually originate from a pressure booster pump set or hydro-pneumatic tank in the basement of the building. In a very tall building, floors should be divided into zones of perhaps 15-20 floors. Each of these will have its own pumping system. This serves to eliminate the very high pressures that result from high water heads, and also reduces pipe and pump sizes.
- Down-fed systems usually originate from a rooftop gravity tank. These are used when a building is too tall for an up-feed system.

Choosing a system depends on the height of the building and the pressure required for operating the fixtures.



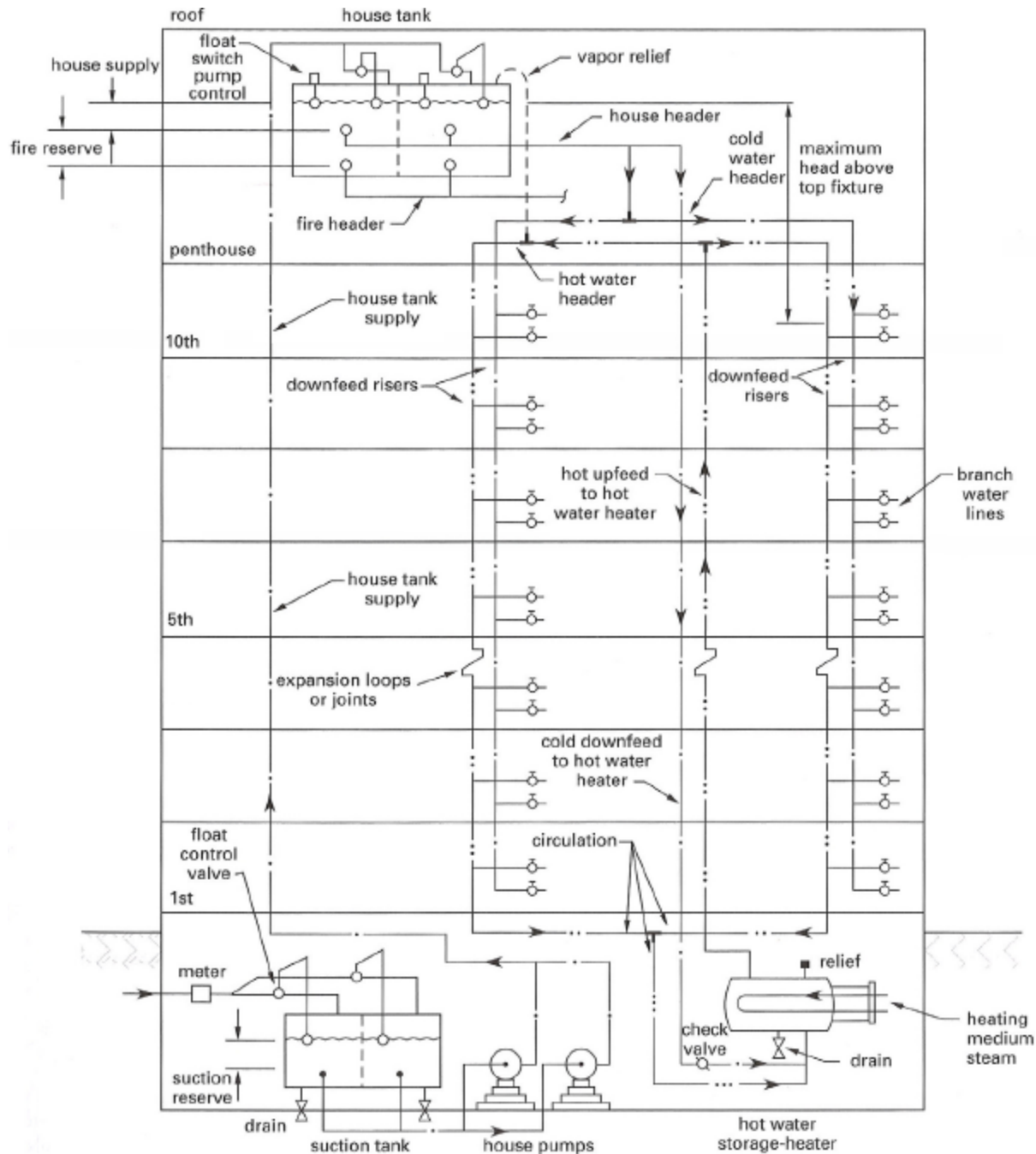

**Up-feed / Down-feed Water Supply System**

### Water Pumps

There are essentially two different types of pumps one may use: submersible pumps, which are designed to be placed inside the water in the tank, and conventional centrifugal pumps, which should be placed in the pump room.

- If using conventional pumps, the outlet from each tank to the pumps should be placed in a sump.
- If no sump is provided and the outlet is placed say 6 inches above the tank bottom. Whenever the tanks are to be cleaned, a de-watering pump will have to be brought in to remove the water in the dead volume of 6 inches.
- If using submersible pumps, provide a deep sump (at least 24 inches), as these pumps are normally installed vertically, and the water inlet is in the middle of the pump and not at the bottom. The pump should be supported only by the delivery pipe, which is bolted to a flange attached to a sleeve in the roof of the tank. If the pump is to be removed for maintenance, this arrangement allows the bolts to be undone, allowing one to easily lift the pump out of the tank without draining the water. For this purpose, a manhole must be placed next to the delivery pipe. Such pumps must not be mounted on the floor of the tank because the fixing bolts will puncture the waterproofing layer of the tank.
- All pump rooms should without fail have an arrangement for floor drainage; pumps always leak. The best way to do this is to slope the floor towards a sump, and install a de-watering pump if the water cannot flow out by gravity.

## PLUMBING FIXTURES

Plumbing systems must be sized to accommodate peak usage of different fixture types.

The fixture unit concept is a method of calculating potable water supply and drainage piping requirements within large buildings. Theoretically, all pipes should be of such a size as to be capable of serving the fixtures to which they are connected when all other fixtures in the building are being operated at the same time. In practice, the chances of their simultaneous use are remote and the piping design criteria may be relaxed to some degree.

The fixture unit (f/u) method of estimating potable water demand is based on:

- The rate of water consumption
- The length of time it is normally in use
- The average period between successive uses

Some examples of fixture unit values assigned to the most common fixtures are given in Table below. When these are added their total gives a basis for determining the flow that may be expected in a water or drainage pipe to which two or more fixtures are connected. The total is then reduced by a factor, usually in the order of 0.6 to 0.7, but depending upon the margin of simultaneous use protection necessary under local conditions.

The total number of fixture units connected to each branch pipe is then added, multiplied by the factor referred to above, and the result used to calculate the flow in water or drainage pipes in accordance with tables such as the following examples. If included in, or annexed to, a plumbing code, these tables should be detailed for a larger schedule covering the whole range of fixture unit values to be expected; examples may be found in various national codes.

FIXTURE UNIT VALUES FOR SOME COMMON PLUMBING FIXTURES

Fixture	Fixture units
Bath or shower	2
Bidet	2
Clothes washer (automatic)	3
Drinking fountain	3
Kitchen sink	1.5
Urinal or water closet (with flush tank)	3
Urinal or water closet (with flush valve)	6
Washbasin	1

Source: Taylor & Wood 1982 (p. 153)

From the table below, the peak demand may be calculated. Fixtures using both hot and cold water (such as in baths and sinks) should be assumed to take equal quantities of each for design purposes: a bath would be counted as one fixture unit on the cold water system, and one fixture unit on the hot water. Supply piping would be calculated accordingly, while the total figure of two fixture units would be used to design the drainage piping.

PEAK WATER DEMAND OF PLUMBING FIXTURES

No. of fixture	US gallons
5	3.65
10	5.39
20	8.56
50	17.94
100	26.51

Source: Taylor & Wood 1982 (p. 153)

**HOT WATER SYSTEM**

Buildings such as hospitals, hotels, multiple dwellings and schools require large quantities of water to be heated, stored and distributed. Heating is usually carried out by a separate boiler, a steam coil or a heat exchange from a central heating or other system, and the temperature is normally controlled to within narrow limits, 120 – 140°F. The acceptable temperature of hot water systems at the tap should be less than 140°F to avoid scalding and above 120°F to prevent the growth of Legionella organisms.

Water heaters for the supply of hot water should always be installed strictly in accordance with the manufacturer’s written instructions.

**Water Heaters**

- They are designed to keep water at any desired temperature, typically the highest point of use during the day;
- When sizing hot water systems for commercial and institutional buildings. it is important to consider the tradeoff between recovery time and storage capacity;
- Hot water heater size is based on the total daily and peak hour hot water demand in a building; and

- They can range from 0.4 gal. per person peak in an office to 12 gal. per unit in a small apartment building.

### Storage Water Heaters (Tank)

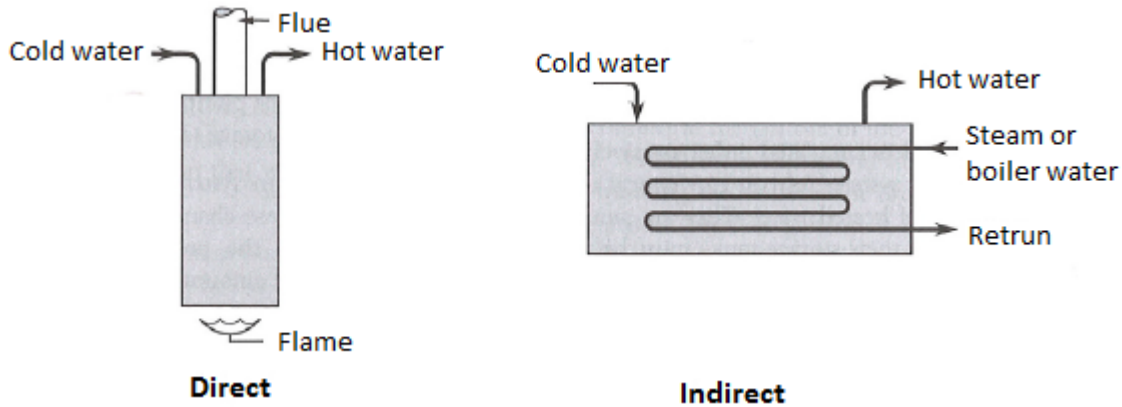

- Fueled by natural gas, propane, oil, electricity;
- Most common water heating type in the US;
- Residential tanks typically 40 - 60 gallons at 50-100 psi;
- Residential tanks typically 120 - 180°F;
- Less conventional systems are heat pump or solar water heater.

### Tank less Water Heaters

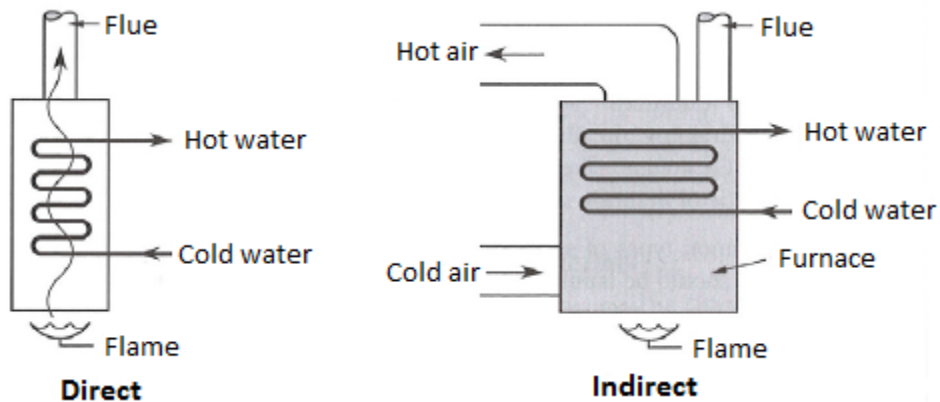

- Water is quickly heated and sent to where it's needed, as it's needed;
- Uses variable speed pumps that run at varying rates;
- Saves space, but pumps wear out faster.

## Circulating Water Heater

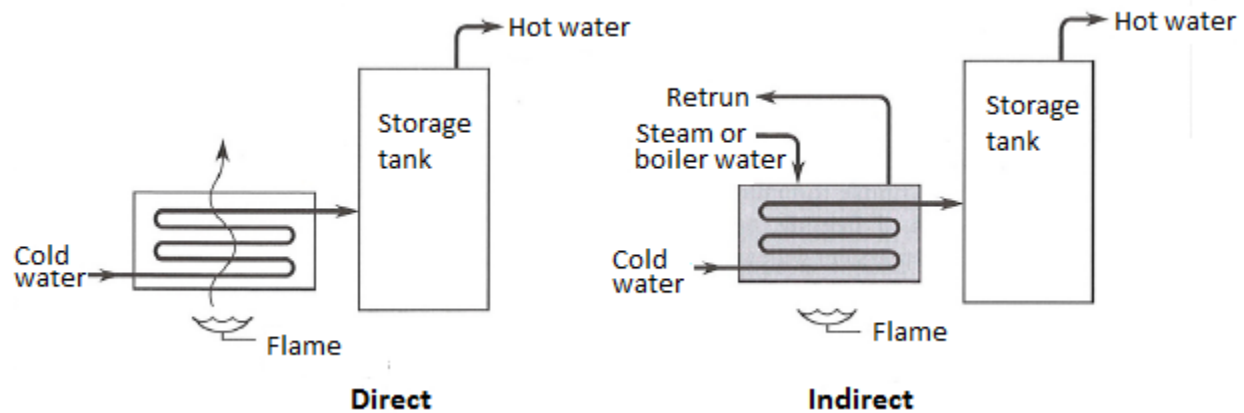

- Water is heated in one spot and stored in another until it's needed;
- Water is supplied to each fixture and heated when the water faucet is turned on;
- More efficient, but more upfront cost to install.

## DRAINAGE SYSTEMS

The other aspect of plumbing is drainage.

Drainage means that part of a plumbing installation which conveys the waste water, sanitary and storm water from a building to a connecting sewer or to a common drain or to any other means of sewage disposed on the site concerned.

### Sanitary Drainage

Any drainage that might include human waste. This is further sub-divided into two types of wastewater:

- **Grey water:** means wastewater from baths, showers, basins, drinking fountains, washtubs, kitchen sinks, washing machines, and the like. Normally as a rule, a minimum of 3-inch diameter pipes are used for wastewater.
- **Soil water:** means any liquid containing excreta and includes a bedspan sink, water closet (WC) pan, urinal, squatting pan, etc. This is also called Blackwater. Soil Pipe means a pipe conveying soil water from the trap or outlet of a soil fixture to a stack or drain. Normally as a rule a minimum of 4-inch diameter pipes are used for soil water.

### Storm Water Drainage

Any water resulting from a natural precipitation or accumulation, and includes rainwater, surface water, subsoil water and spring water. Storm water drain means a pipe or surface channel, which is used for the conveyance of storm water to a sewer or a point of discharge acceptable to the local authority.

Sewage means waste water, soil water or trade effluent and other liquid waste either separately or in combination, but shall not include storm water.

## DRAINAGE SYSTEM CONSIDERATIONS

The drainage system is intended to safely carry away sewage to a disposal system. Removal of solid water and waste is done without air pressure and by avoiding odors and siphonage.

In the drainage system, the drains from the plumbing fixtures are connected to vertical drain stacks that convey the waste and sewage to below the lowest floor of the building.

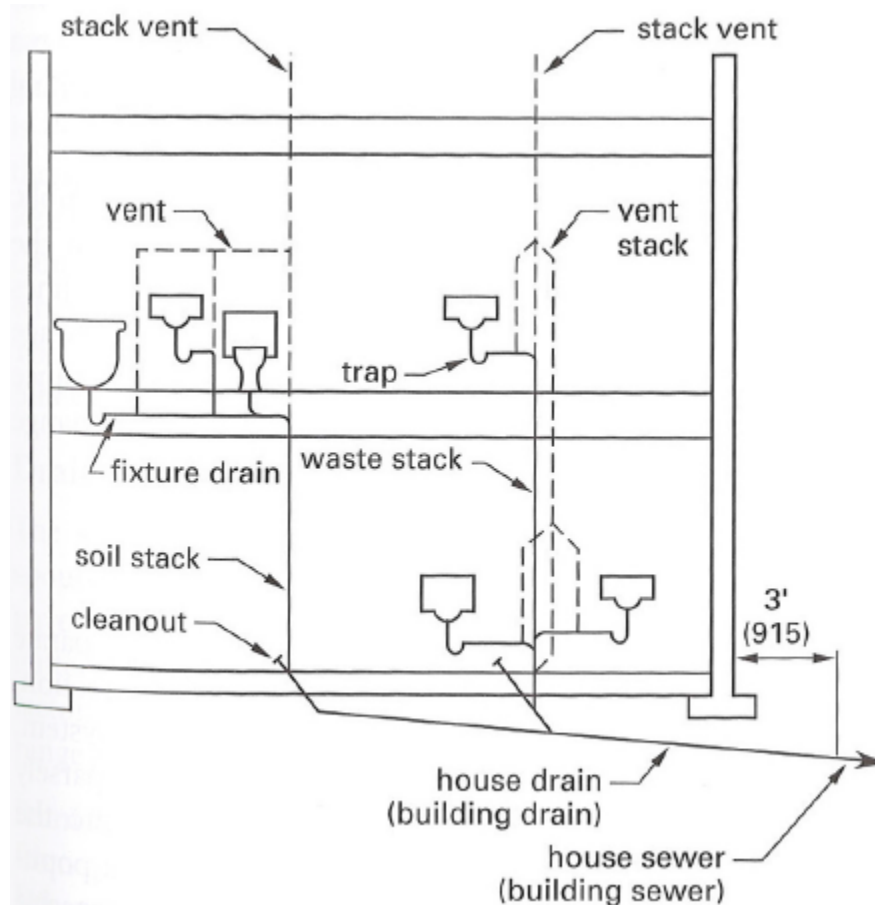

Traps are located at every fixture and hold some water that makes a seal used to prevent gasses from the sewage system from entering the building. Traps are installed within 2 feet of the fixture.

The fixture drain traps must be vented to prevent their water trap seal from being siphoned by negative pressure or blown out by positive pressure in the drain piping. The fixture vent pipes must extend through the roof to outdoors. They can be run individually or be combined into one or more vents through the roof.

Where buildings are over 10 stories high, the drainage stacks require relief vent connections at specified intervals from the top, and connected to a vent stack that terminates above the roof. This relieves and equalizes the pressure in the drainage stack to maintain the water seal in traps serving plumbing fixtures.

Wherever possible, the sanitary drainage system from a building should discharge to the public sewer by gravity. All plumbing fixtures located below ground level should be pumped into the public sewer or the drainage system leading to the sewer. The pump line should be as short as possible and looped up to a point not less than 24 inches above ground level to prevent back-siphonage of sewage. The pump discharge rate should be controlled so as not to cause scouring of the internal bore of the pump line or the drainage or sewer system into which it discharges.

High-velocity discharge rates may also cause the flooding of adjoining plumbing fixtures or overloading of the sewer itself. The sump pits for sewage pumps must have sealed covers, be vented to outdoors and have automatic level controls and alarms. Sewage pumps in multiple dwellings and in multi-storey dwellings should be duplex, with each pump having 100% of the required pumping capacity for the building. Alternatively, an approved vacuum drainage system may be considered.

## SEWERAGE SYSTEM

Because the wastewater is not treated before it is transported, the sewer must be designed to maintain self-cleansing velocity (i.e. a flow that will not allow particles to accumulate), generally obtained with a minimal flow of 2 feet per second.

When the required slope cannot be maintained, a pumping station must be installed. Primary sewers are laid beneath roads, at minimal depths of 1.5 to 3 m to avoid damages caused by traffic loads.

Access manholes are set at regular intervals along the sewer, at pipe intersections, at changes in pipeline direction and at drops to provide a high level of hygiene and comfort for the user at the point of use.

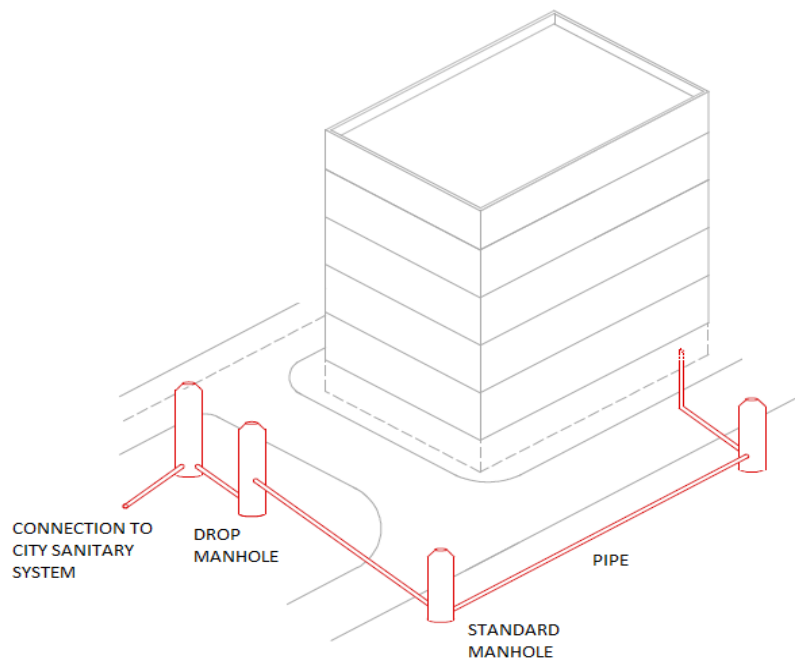

Manholes are installed wherever there is a change of gradient or alignment.

Drainage slopes are typically 1/4" per foot for typical effluent waste lines. Drains are maintained at 45° for waste lines that are gravity only.

The following are minimum slopes for PVC pipe (n=0.011):

Size (inches)	Minimum Slope (ft./foot)
8	0.0040
10	0.0028
12	0.0022
15	0.0017
18	0.0012
21	0.0010
24	0.0008

Wherever possible, sewer pipe shall be installed at least 10-feet horizontally from any existing or proposed water main. If horizontal separation is not possible, the pipe should be installed in a separate trench or on an undisturbed earth shelf located on one side of the water main. The top of the sewer main should be at least 18-inches below the invert of the water.

Interior drop manholes should be installed for vertical drops greater than 2 feet. Use 4-foot diameter manholes for pipes up to 24 inches. Distance between manholes should generally not exceed 400 feet.

An interior drop manhole is recommended when the elevation drop is greater than 2 feet between the pipelines.

A grease trap should be used when draining waste from large kitchens or massage parlors; grease should not be allowed to enter the normal drainage system. A grease trap is nothing but a small inspection chamber. The grease floats should be removed manually on a daily basis. The inlets and outlets into this chamber should be designed in a way that minimizes disturbance of the floating grease layer.

## STORM WATER SYSTEM

The three basic storm water quality control strategies are as follows:

- Infiltrate runoff into the soil;
- Retain/detain runoff for later release; and
- Convey runoff slowly through vegetation.

The system must drain by gravity and requires larger pipes.

Routing storm water inside a building can be a problem because of sweaty pipes.



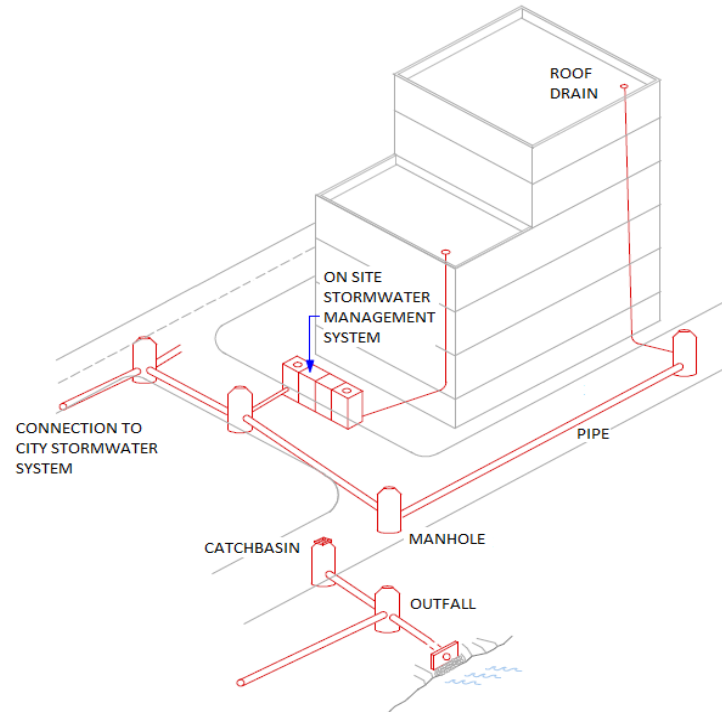

## TYPICAL PLUMBING SYSTEM COMPONENTS

### Piping

There are a range of choices for the distribution network of pipes; GI, CPVC (chlorinated PVC), HDPE (high-density polyethylene), and copper. These days plastic (CPVC, HDPE) pipes are preferred to others because they do not rust, are light and easy to install, and inexpensive.

- **Copper Pipe:**
  - Type K: thickest wall, comes in straight lengths, coils, and used for underground supply when greatest strength is required
  - Type L: thinner walls and comes in straight lengths or coils, commonly used for most interior plumbing (most common)
  - Type M: thinnest and available in straight length only. Used where there is low pressure, like branch supply, chilled water, and drainage.
- **Galvanized Steel:** used when water is not corrosive, difficult screw fitting assembly. Schedule 40 pipe is most common. Joined mechanically with threaded collars.
- **Plastic:** used in residential for supply piping. Is still restricted by some codes. Expands 3.5 times more than copper. Joined by primer.
  - Polyethylene (PE): plastic pipe and tubing
  - Acrylonitrile Butadiene Styrene (ABS): plastic pipe, black, used only for drain lines
  - Polyvinyl Chloride (PVC): plastic pipe, white, used for supply
  - Polyvinyl Di-chloride (PVDC): (okay for hot water)

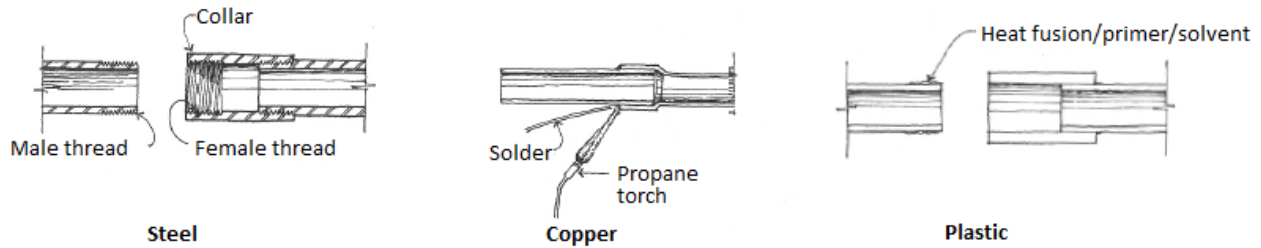

## CHECKLISTS

### Building Layout Considerations

General checklist and layout considerations that will minimize plumbing infrastructure costs:

- Domestic water meter needs to be located within 2'-0" of the front wall of the building and within 50'-0" of the property line, otherwise outdoor meter vault will be required.
- Plumbing equipment room should be as close as possible to main bathroom groups and kitchens.
- Outdoor and indoor large grease interceptors should be located where pumper trucks can easily access them.
- Consider ceiling construction that allows for a minimum number of plumbing access panels on floors where domestic distribution piping is routed or on floors where multiple sanitary cleanouts will be located in the ceiling space.
- On multi-floor projects, stack plumbing fixtures and plumbing chases wherever possible.
- Avoid locating plumbing fixtures directly above overhangs or unheated garage spaces, if possible.
- Do not locate fixtures on the exterior walls of the building.
- Ensure that enough room is provided for water mains to exit plumbing equipment room without running into spaces such as electrical rooms, staircases, and elevator shafts.

### Plumbing Fixture Location and Roof Drain Location Checklist

Plumbing fixtures or roof drains must not be located over these spaces:

- Electrical rooms
- Electrical closets
- MDF rooms
- Elevator equipment rooms
- Fire pump rooms
- Staircases
- Elevator shafts

Drainage pipes from plumbing fixtures or roof drains located over these spaces will require drain added pans (increasing construction costs):

- Kitchens
- Food prep areas
- Dining areas

Drainage pipes from plumbing fixtures or roof drains located in these spaces will require heat tracing:

- Overhangs open to outside air
- Exterior
- Unheated garages
- Unheated storage rooms adjacent to exterior walls of the building
- Structural constraints

### **Structural Constraints**

- Plumbing chases and fixtures should not be located over structural footings, which are located directly under the floor slab
- Plumbing chases should not be placed directly over structural beams (structural beams are commonly aligned with column lines)
- Plumbing chases should not be placed at structural expansion joints

\*\*\*\*\*

## CHAPTER – 8 ELECTRICAL SYSTEMS

For electrical systems, the design parameters are set in accordance with the National Electric Code (NEC). These are the minimum requirements that must be met. The major categories of the electrical system are supply, distribution, motor loads and lighting.

### ELECTRIC POWER SYSTEM

The principal elements of an electric power system are the generating stations, the transmission lines, the substations, and the distribution networks. The generators produce the electricity, the transmission lines move it to locations where it is consumed, and the substations transform it for industrial, commercial, and residential use.

The most common form of energy used in buildings is alternating (AC) current. Direct Current (DC) is used for some types of elevator motors and low voltage applications like signal systems and controls.

Power in buildings is supplied either as single phase or three phase AC system.

#### Single Phase Power

Single-phase power consists of voltage and current that varies at the same frequency. This sort of distribution is most common when the power load is primarily used for lighting, low power appliances, heating and low horsepower motors (less than 5HP).

In the U.S., single-phase voltage is 120 Volts, while several other countries use 230 Volts as the standard.

A typical single-phase power system contains three wires, a power wire, a neutral wire and an earth/ground wire.

#### Three Phase Power

Three Phase power refers to three wire Alternating Current (AC) power circuits, which are synchronized to switch direction at different times but all at the same voltage. Compared to single-phase power circuits, 3-phase power circuits provide 1.732 (the square root of 3) times more power with the same current.

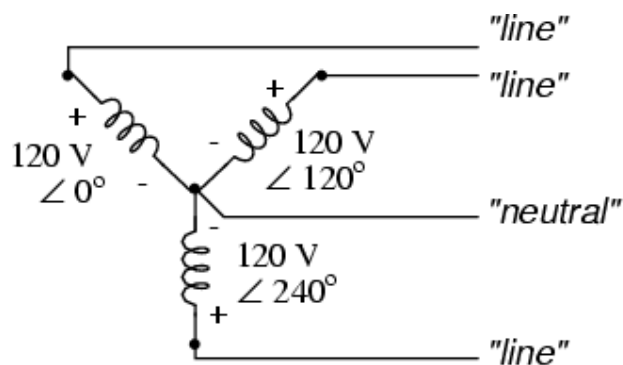

A three-phase system comes in three power wires, a neutral wire and an earth/ground wire that is often optional.

For three phase, power can be drawn either by the delta configuration or by the wye configuration. A delta configuration produces 208V and the wye configuration produces 120V (shown above).

This kind of flexibility helps balance power for different equipment in an establishment. Low power loads (lights, computers, etc.) are powered using any 120V single-phase power circuit and high power loads (Water Heaters, AC Compressors) are powered using the 208V three-phase power circuit.

### **Important**

- Commercial and Industrial buildings typically use single or 3-phase systems.
- 3-phase power is equivalent to three connected single-phase systems.
- Utility companies produce only 3-phase power.
- Single-phase output can be derived from 3-phase input, but not the converse.

### **Advantages of 3-phase power**

Three-phase power distribution requires lesser copper or aluminum for transferring the same amount of power as compared to single-phase power. Only about 75 percent as much copper wire is required for distributing three-phase power as is required for distributing the same amount of single-phase power.

## **POWER DISTRIBUTION IN SMALL BUILDINGS**

An electric power distribution system carries electricity from the transmission system to individual consumers. Distribution substations connect to the transmission system and lower the transmission voltage to medium voltage ranging between 2 kV and 35 kV with the use of transformers. Primary distribution lines carry this medium voltage power to distribution transformers located near the customer's premises. Distribution transformers again lower the voltage to the utilization voltage of household appliances and typically feed several customers through secondary distribution lines at this voltage. Commercial and residential customers are connected to the secondary distribution lines through service drops. Customers demanding a much larger amount of power may be connected directly to the primary distribution level or the sub-transmission level.

In the United States, power companies provide electricity to medium or large buildings at 13,800 volts (13.8kV). Small commercial and residential buildings usually get 120/240 Volts single phase or 120/208 volts three-phase service. The power distribution company provides a step-down transformer on a pole or on the ground to reduce the voltage to 120/240 or 120/208 volts typically required by small and medium sized buildings.

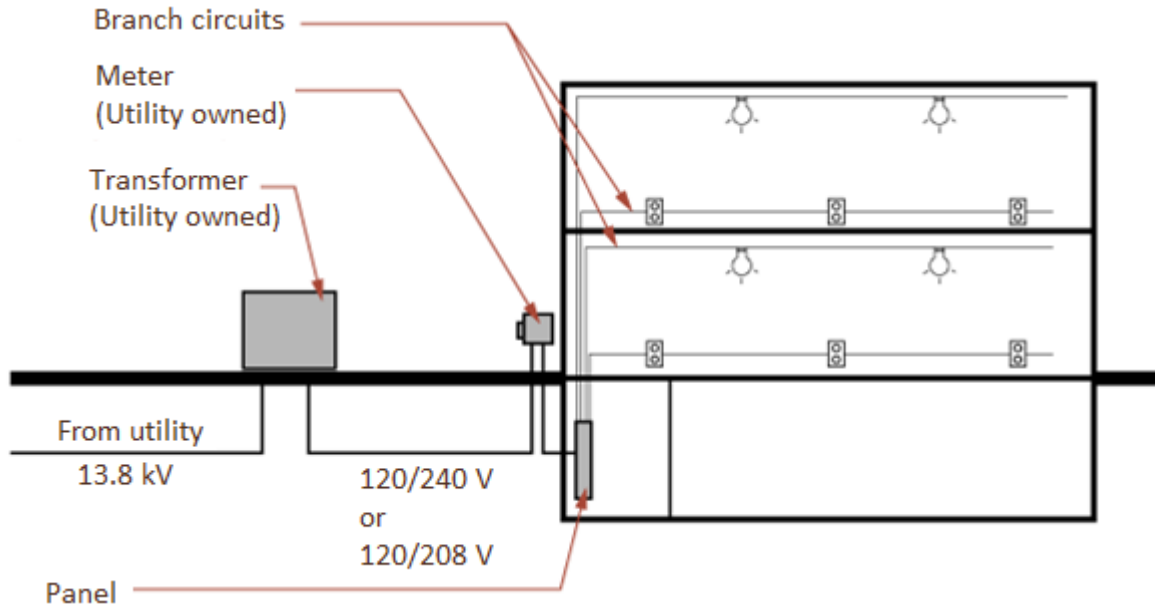

### Power Distribution in Small Buildings

The power distribution company terminates the wires up to the electric meter. Beyond this, the property owner provides all wiring, panels, and other electrical devices.

### POWER DISTRIBUTION IN LARGE BUILDINGS

Larger commercial and Industrial customers require higher voltage (typically 480/277 volts). In this case, the owner of the property provides and maintains their own step-down transformer. Downstream the transformer is the switchgear. It functions to distribute electricity safely and efficiently to the various loads throughout the building. The switchgear includes numerous circuit breakers, which disrupts the power supply in the event of a fault or problem. It can also be triggered off manually to allow technicians to work on specific branches of the power system.

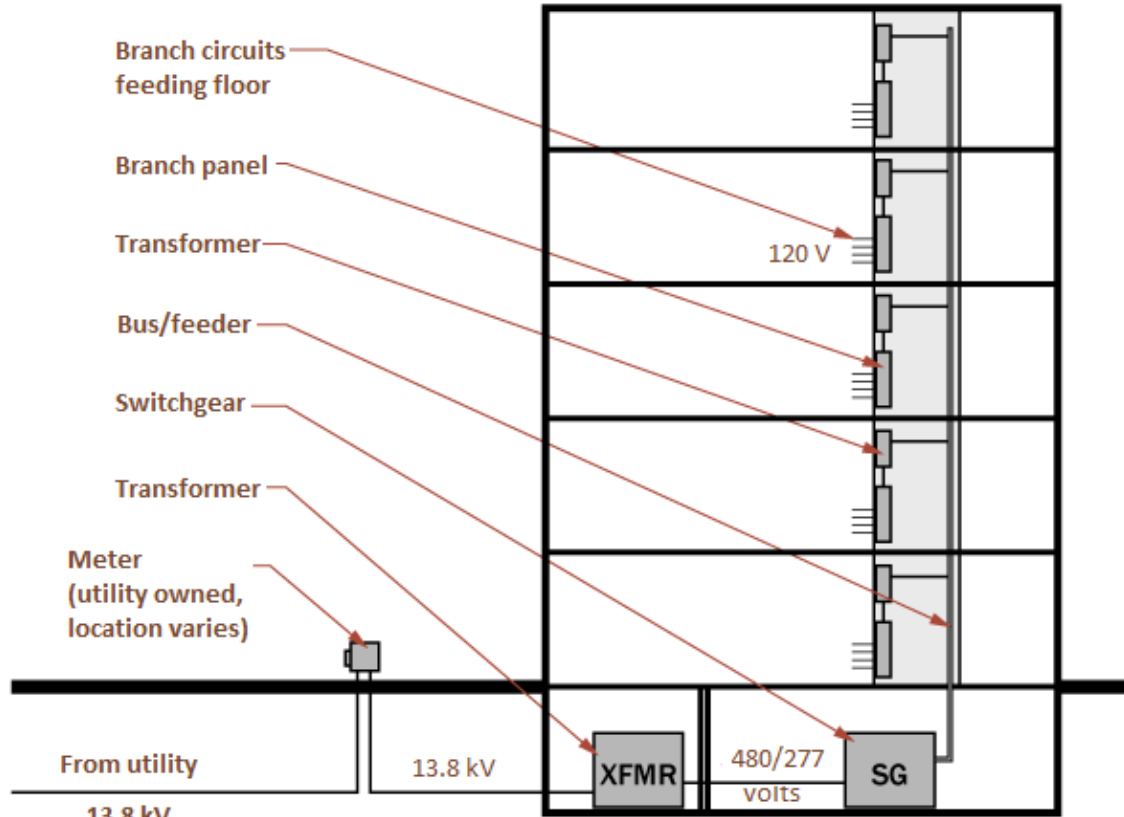

**Diagram of Power Distribution in Large Buildings**

Metering must be provided before the building service enters switches. The meter station is either located at the utility side or the facility's service point inside the building. Utility companies levy charges based not only on the total amount of energy used (kWh) but also on peak demand. A low load factor impels an inefficient use of energy and a high demand charge. It also encourages conservation of energy because utility companies have to provide energy based on peak.

The following are factors to be considered for proper distribution of power supply:

- After office hours, all LT panels should be switched off. Only supply of emergency areas such as specific lift, staircase/corridor/compound lights, fire protection board, pumps, server/computer room, and security lights may be kept on.
- Earth continuity should be ensured for all metallic boxes and earth pin of socket outlets.
- Degree of protection required for outdoor/indoor cubicles shall be ensured.

## ELECTRICAL TERMS AND COMPONENTS

### Circuits

A circuit is a current carrying path between two or more points.

Circuits can be interrupted by a switch. A circuit breaker is a device that interrupts the path when necessary to protect other devices attached to the circuit, for example, in case of a power surge.

Circuits can be classified as:

- **High Voltage Circuits** = >1,000 V A/C power or > 1,500 V D/C power. Used in electrical power distribution.
- **Low Voltage Circuits** = 50 - 1,000 V A/C power or 120 - 1,500 V D/C power.
- **Extra Low Voltage Circuits** = < 50 V A/C power or <120 V D/C power. Extra low voltage is a low risk, and used for things like intercoms, remote lighting, doorbells, HVAC.

### Electrical load

An electrical load is that item of a circuit, which consumes electric power. The examples are the appliances, lights, air conditioning equipment, pumps, etc. The term may also refer to the power consumed by a circuit. This is opposed to a power source, such as a battery or generator, which produces power.

### Conductors

A conductor is a material typically copper wire through which current flows. The voltage (the potential difference) causes the current to flow.

The current carrying capacity of a conductor depends on the size, type of insulation around it, and surrounding temperature.

### Feeder

A feeder is a set of electrical conductors, which extend from the source of energy to a distribution center.

### American Wire Gauge System

Wires are sized to carry more current than load.

Loads should be less than two-thirds of rated conductor load rating to allow for growth.

Size of conductors is based on the cross-sectional area specified in the American Wire Gauge (AWG) and thousand circular mil (MCM) designations. Increasing gauge numbers give decreasing wire diameters. For example:

- No. 36 AWG = 0.005 inches;
- No. 0000 AWG (aka 4/0 pronounce “four aught”) = 0.46 inches;
- Larger than 4/0 is MCM cable sizes of 250, 400, and 500;
- Circular Mil: the area of a wire having a diameter of one mil or 0.001 of an inch, used in specifying wire size

All connections (e.g. switches, receptacles, lights and junctions) must be made within code-approved boxes.

Conduits for electrical power should be independent of conduits used for transmission of voice or data.



## Wire Types

Type	Use	Description
Aluminum  Wire Types (No. 8 AGW or smaller)	Commercial	Requires a special installer.  Oxide can form when joints loosen and/or overheats.  Must be larger than copper to carry amperage.  Cheaper than copper.  Limited to primary circuits because of overheating.
Copper  Wire Types (No. 8 AGW or smaller)	Residential/Small Construction	Same carrying capacity as aluminum but smaller.  Most cost effective for small and medium sized wire and cable.
Romex  (No. 6 AGW or larger, or several conductors assembled into a single unit )	Residential, Wood Framed less than 3 stories	Nonmetallic sheathed cables.  No conduit required, it's an alternative.  Must be protected from damage within walls, etc.
Flex Metal Clad Cable (BX)  (No. 6 AGW or larger, or several conductors assembled into a single unit )	Remodel/Residential	Flexible metal clad cable.  2+ plastic insulation conductors encased in spiral wound strip of steel tape.  No conduit is required.  Can be easily pulled.
Busbar  (No. 6 AGW or larger, or several conductors assembled into a single unit )		Rectangular bars of copper that carry high voltage and high currents.  Used in place of very large cables.
Busway  (No. 6 AGW or larger, or several conductors assembled into a single unit )		Multiple busbars in a metal housing.

## Raceways

Raceways are the channels for holding electrical cables, and they are used for large residential, commercial and industrial projects.

A raceway layout is one of the major considerations in design. It must be addressed early in the design process because the proliferation of numerous loads, control devices, computers and networking equipment require the distribution channels to be much wider than before.

## Conduits

An electrical conduit is a piping system that protects wires and cables from impact, moisture, and vapors. It allows cables to be easily pulled and makes wiring changes simpler and safer. NFPA 70, also known as the National Electric Code (NEC), provides information on the safe and proper way to install conduit and associated cabling.

Conduit materials are often chosen for their mechanical protection, corrosion resistance, and the overall installation cost.

Type	Use
Rigid Steel	<p>The safest type</p> <p>After pipe is installed (indoor/outdoor) wires are pulled through</p> <p>Connections are rigid and threaded like plumbing pipes</p> <p>Connect to J-boxes and devices</p>
Intermediate Metallic	<p>Steel conduit with thinner walls but same outside diameter as Rigid</p> <p>More economical</p> <p>Use with threaded fittings</p>
Flex (Flexible Metal)	<p>Used everywhere except underground</p> <p>Reduces vibration transmission from equipment where not possible to install rigid</p>
Electric Metallic Tubing	<p>Thinnest metal conduit</p> <p>Too thin to thread, connections are made with clamps</p> <p>Easy/fast install</p> <p>Not allowed in hazardous areas</p>

## Capacitors

Capacitors are used in three-phase circuits to improve the power factor (useable power).

It comprises two plates separated by an insulating layer. Current is stored on one plate and eventually the stored amount is discharged. It is used in single-phase motors for starting.

### Transformer

A transformer is a device used to increase or decrease AC voltage. Note it changes the voltage but not the total power.

It is comprised of primary and secondary windings about an iron core. Primary windings are used for input in a transformer. Secondary windings are used for output and can be divided into segments so that the output voltage could be adjusted on the settlements used. The wire with a greater number of winds has a higher voltage and the wire with less winds has a lower voltage.

An efficient transformer wastes approximately 2% of power flowing through it.

Step-up transformers increase the output voltage (e.g. they increase voltage from a power plant to transmission lines). Step-down transformers decrease the output voltage (e.g. they reduce voltage from transmission lines at sub-stations or at transmission poles).

### Circuit Connections

Connections are either wye (shaped like the letter Y) or delta (shaped like a triangle) format.

- **Wye:** used when all the loads in an AC system are connected at a single point and a neutral cable is connected at that center point where the three phases meet. Most low voltage distribution lines such as lighting circuits are Wye. Wye connections are symmetrical so the voltage from each of the three-phase wires to the neutral is the same. That means that the voltage from each phase to the neutral equals the voltage from the line-to-line divided by  $\sqrt{3}$  (or 1.73).
- **Delta:** used when three phases are connected like a triangle and do not have a neutral cable. Delta connections are usually made when load is mainly power. Primaries are usually connected to a Delta. If a neutral is added to a delta, the voltage from two of the phase wires to the neutral is 1/2 of the phase-to-phase voltage. The voltage from the third phase to the neutral is 0.866 times the phase-to-phase voltage; no loads are connected between these two points though.

### Switchgear

Switchgear is an assembly of switches, circuits breakers and cables or bus ducts that distribute power to the building or to substations for further transforming and distribution as part of a secondary distribution system.

### Distribution boards

Distribution board or panel board is an enclosed cabinet containing circuit breakers which serve as a distribution point of branch circuits to a floor or part of a floor.

## Switchboard

A Switchboard is used in large installations. It is located in special rooms large enough to permit services access around the equipment. Equipment include transformers, circuit breakers and distribution panels.

## Branch Circuit

The insulated wires that run between the outlet and the panel board. Examples of branch circuit loads for residences are:

- Lighting and general-use circuit loads involve current flowing to most lights and wall receptacles: NEC recommends 3 watts/sq.-ft. of finished floor area.
- Small-appliance circuit loads involve current flowing to fixed small appliances (e.g. in Kitchen/Dining room and Laundry) not to be served by general-use circuits. NEC requires a minimum of two 1,500W circuits in the Kitchen for dishwasher, microwave, etc.

## Circuit Protection

Devices used to protect from overload and short circuiting.

## Grounding

Grounding or Earthing is a safeguard that allows a current to find an easy path to the earth, eliminating electrical load and protecting people from shock.

It involves a direct physical connection of both the ground wire and neutral wires to the earth. It provides a path for fault and prevents the risk of electric shock. It is important to prevent user contact with dangerous voltage if electrical insulation fails.

Ground is the conductor between the circuit and the earth.

## Ground Fault Interrupter (GFI/GFCI)

Devices, which detect a continual current lost to the ground (earth), even after power is shut off.

Typically used on any 15 or 20-amp circuit where water is or might be present (e.g: bathrooms, garages, outdoors)

If an outlet is within 6'-0" of a water source, then it must be connected to an GFCI to eliminate potential shock hazard.

## Fuses

A fuse is a thin strip of metal that melts and breaks an electrical circuit if a current exceeds a safe level. It can be used only once as when it breaks it is done.

## Circuit Breakers

Each live wire is connected to a circuit breaker and the ground cable connected to an electrode driven into the earth.

A Circuit Breaker disconnects electrical current automatically when an overload occurs. It must be reset manually once it is triggered.

Breaker size is specified to match the capacity of the conductor. A circuit that feeds a motor must be oversized so that the rated load of the motor is not more than 80% of the capacity of the circuit. NEC requires that for single motor installation. The current used in the wire size calculation must be 1.25 times the load current from the applicable single-phase or 3-phase tables.

## Contactors

Contractor is a magnetically operated switch to open and close an electric current. It is similar to relay but with higher current ratings.

It is controlled by a circuit, which has a much lower power level than the switched outlet. It is used to control electric motors, lighting, heating, capacitor banks, thermal evaporators, and other electrical loads.

Unlike switches, contactors can be remote controlled.

## Receptacles (aka Outlets)

**Duplex:** operate at 120V or higher depending on the appliance.

**Ground fault circuit interrupter (GFCI):** used for safety.

**Hard wired:** The wiring that is connected directly to building circuits in junction boxes.

**Split Wire receptacle:** one outlet is always in energizing mode, the other is controlled by a switch.

- Receptacles should be mounted 12" - 18" above finished floor typical, min 15" for ADA.
- Spacing should be 12'-0" max, or so that no point is further than 6' from an outlet.
- Floor receptacles must be within 18" of an exterior wall to count as a required power receptacle in a dwelling.
- Circuits are usually 15" and at least 20A for the kitchen, pantry, and dining.
- Kitchen counters need at least two circuits, with no more than 4 outlets per 20A.
- No point on a wall above a counter can be greater than 24" from an outlet.

## Emergency Power Supply

System designed to provide emergency power supply to exit lighting, alarms, elevators, computer equipment, etc.

If a building's emergency power supply consists of batteries, the batteries must have a full-load capacity of 90 minutes.

## Uninterruptible Power Supply (UPS)

An electrical apparatus that provides emergency power to a load when the input source fails. It is typically used wherever power outage can disrupt business, for example, to protect computers, data centers, telecom equipment, etc.

## LIGHTING IN BUILDINGS

### Lighting output

The most common measure of light output is the lumen. Light sources are labeled with an output rating in lumens. For example, a T12 40-watt fluorescent lamp may have a rating of 3050 lumens.

Similarly, a light fixture's output can be expressed in lumens. As lamps and fixtures age and become dirty, their lumen output decreases (i.e., lumen depreciation occurs). Most lamp ratings are based on initial lumens (i.e., when the lamp is new).

### Lighting level

The amount of light arriving at a surface is the Illuminance measured in foot-candles, which is equal to lumens per square foot.

In an office, we might want to understand the amount of light that is hitting our desk; however, in a gymnasium or corridor we may be more interested for light hitting the floor. Illuminance is measured in foot-candles (FC) or lux. You can measure illuminance using a light meter located on the work surface. Using simple arithmetic and manufacturers' photometric data, you can predict illuminance for a defined space. (Lux is the metric unit for illuminance, measured in lumens per square meter. To convert foot-candles to lux, multiply foot-candles by 10.76.)

### Luminance

Luminance is the brightness measured in foot-lambert's (fL) or candelas/m<sup>2</sup>.

This measures light "leaving" a surface in a particular direction, and considers the illuminance on the surface and the reflectance of the surface.

The human eye does not see illuminance; it sees luminance. Therefore, the amount of light delivered into the space and the reflectance of the surfaces in the space affect your ability to see.

## RECOMMENDED LIGHT LEVELS BY SPACE

The table below provides recommended light levels from the IESNA Lighting Handbook and LPD levels from the IECC 2015. The required light levels are indicated in a range because different tasks, even in the same space, require different amounts of light. In general, low contrast and detailed tasks require more light while high contrast and less detailed tasks require less light.

ROOM TYPE	LIGHT LEVEL (FOOT CANDLES)	LIGHT LEVEL (LUX)	IECC 2015 LIGHTING POWER DENSITY (WATTS PER SF)
Bedroom - Dormitory	20-30 FC	200-300 lux	0.38
Cafeteria - Eating	20-30 FC	200-300 lux	0.65
Classroom - General	30-50 FC	300-500 lux	1.24
Conference Room	30-50 FC	300-500 lux	1.23
Corridor	5-10 FC	50-100 lux	0.66
Exhibit Space	30-50 FC	300-500 lux	1.45
Gymnasium - Exercise / Workout	20-30 FC	200-300 lux	0.72
Gymnasium - Sports / Games	30-50 FC	300-500 lux	1.20
Kitchen / Food Prep	30-75 FC	300-750 lux	1.21
Laboratory (Classroom)	50-75 FC	500-750 lux	1.43
Laboratory (Professional)	75-120 FC	750-1200 lux	1.81
Library - Stacks	20-50 FC	200-500 lux	1.71
Library - Reading / Studying	30-50 FC	300-500 lux	1.06
Loading Dock	10-30 FC	100-300 lux	0.47
Lobby - Office/General	20-30 FC	200-300 lux	0.90
Locker Room	10-30 FC	100-300 lux	0.75
Lounge / Breakroom	10-30 FC	100-300 lux	0.73
Mechanical / Electrical Room	20-50 FC	200-500 lux	0.95
Office - Open	30-50 FC	300-500 lux	0.98
Office - Private / Closed	30-50 FC	300-500 lux	1.11
Parking - Interior	5-10 FC	50-100 lux	0.19
Restroom / Toilet	10-30 FC	100-300 lux	0.98
Retail Sales	20-50 FC	200-500 lux	1.59
Stairway	5-10 FC	50-100 lux	0.69
Storage Room - General	5-20 FC	50-200 lux	0.63
Workshop	30-75 FC	300-750 lux	1.59

## CHARACTERISTICS OF LIGHT SOURCES

Electric light sources have three characteristics: efficiency, color temperature, and color rendering index (CRI).

- Efficiency:** The efficacy of a lamp refers to the number of lumens leaving the lamp compared to the number of watts required by the lamp (and ballast). It is expressed in lumens per watt.

- **Color Temperature:** This is a measurement of "warmth" or "coolness" provided by the lamp. People usually prefer a warmer source (red, orange, yellow) in lower illuminance areas, such as dining areas and living rooms, and a cooler source (white, blue) in higher illuminance areas, such as grocery stores.
- **Color Rendering Index:** The color rendering index (CRI) scale (ranging from zero - 100) is used to compare how perceived colors match actual colors. It is a measure of the effectiveness of a source to make colors "right" to the viewer. A higher CRI means better color rendering, or less color shift. CRIs in the range of 75-100 are considered excellent, while 65-75 are good. The range of 55-65 is fair, and 0-55 is poor.

## SELECTION FACTORS

The appropriate type and quantity of lamps and light fixtures may be selected based on the following:

- Fixture efficiency
- Lamp lumen output
- The reflectance of surrounding surfaces
- The effects of light losses from lamp lumen depreciation and dirt accumulation
- Room size and shape
- Availability of natural light (daylight)

When designing a new or upgraded lighting system, one must be careful to avoid overlighting a space. In the past, spaces were designed for as much as 200 foot-candles in places where 50 foot-candles may not only be adequate, but superior. This was partly due to the misconception that the more light in a space, the higher the quality. Not only does over lighting waste energy, but it can also reduce lighting quality.

## TYPES OF LIGHTING

### Incandescent

Consists of a tungsten filament placed within a sealed bulb containing an inert gas. Filament glows by passing an electric current through it.

#### Advantages:

- Inexpensive
- Compact
- Dimmable
- Typically, "warmer" color than sunlight or daylight, rich in yellows and reds and weak in green and blues.

#### Disadvantages:

- The least efficient type of artificial lighting because much of the energy used to light the filament is wasted in the production of heat (About 90% waste!).
- Short lamp life: standard bulbs last about 700 - 1,000 hours.



## Tungsten Halogen

A variation of incandescent bulbs. A filament is lit by electricity passing through an enclosed in sealed bulb containing an inert gas and halogen. The filament burns under high pressure and temperature caused by a fused quartz envelope. It is smaller than standard incandescent bulbs.

### Advantages:

- Longer life
- Low lumen depreciation of the life of the bulb
- More uniform light color
- Whiter light than incandescent
- Dimmable

### Disadvantages:

- Much hotter than incandescent bulbs.

## Fluorescent

A glass tube holds a mixture of an inert gas and low pressure mercury vapor. When lamp is energized, an arc of mercury is formed creating an ultraviolet light that strikes the phosphor-coated bulb. Bulb fluoresces and produce a visible light.

A device called ballast supplies the proper starting and operating voltages to the lamp and limits the current. Produces noise and heat so, “Class A” is good for quite areas and “Class F” is acceptable for noisy areas. Electronic ballast produces high frequency AC and lowers power consumption for silent operation and ease of dimming.

### Advantages:

- High efficacy (About 80 lm/W)
- Low initial cost
- Long life (about 10,000 - 20,000 hours)
- Variety of color temperatures (improving...no longer just “cool white”)
- Dimmable
- For fluorescent lamps, dimming down to 40% of output is possible without substantially reducing luminous efficacy.

### Disadvantages:

- More expensive than incandescent bulbs.

### Types

- **T Tube**
  - Designated according to type, wattage, diameter, color, and method of starting
  - Example: F32T8WW/RS = 32 watt, 8/8” tubular, warm white, rapid start

- **CF- Compact Fluorescent**
  - Lamps bent into a U-shape and mounted on a base that houses a ballast
  - Can be screwed into incandescent luminaries

### High Intensity Discharge (HID)

A lamp within a lamp that runs at a very high voltage. An electrical arc is struck across tungsten electrodes in a glass tube filled with gas and metals. Metals produce the light once they are heated to a point of evaporation.

#### Advantages:

- High efficacy (About 80 lm/W)

#### Disadvantages:

- Produce light that is not flattering to human skin, so not used for commercial, retail, or residential applications.

#### Types

##### Mercury Vapor

- Electric arc is passed through high pressure mercury vapor that produces ultraviolet and visibly light
- Primarily in the “blue/green” color
- Moderately high efficacy (30-50 lm/W)
- Have a life of 24,000 hours
- Used for large area overhead lighting in factories, warehouses, sports complexes, or streetlights

##### Metal Halide

- Similar to mercury vapor except halides of metal are added to the arc tube
- Increased efficacy (50 - 100 lm/W)
- Have a life of 10,000 hours
- Produces a whiter, more natural light
- Decreased lamp life

##### High Pressure Sodium

- Produces light by passing an electric arc through hot sodium vapor
- Arc tube must be ceramic to resist hot sodium
- High efficacy (80 - 140 lm/W)
- Have a life of 24,000 hours
- Wide variety of color rendition

### Low Pressure Sodium

- Operates like a fluorescent lamp and requires a ballast
- Highest efficacy (150 lm/W)
- Require a brief warmup period to reach full brightness
- Produces a monochromatic yellow light
- Used where color rendition is not important (e.g.: parking garages, street lights)

### Light Emitting Diode (LED)

- Solid State Lighting
- Bulbs without a filament, plasma, or gas
- Low in power consumption with a long life span
- Diodes emit light when connected in a circuit
- Run on DC power
- Used for flashlights, signage, sustainable lighting, phones, video production

### Typical Efficacy

Incandescent	12 lumens/watt (these suck)
Fluorescent	55 lumens/watt
Metal Halide	90 lumens/watt (good for libraries)
High Pressure Sodium	90 lumens/watt (street lights)
Sunlight	115 lumens/watt (nothing beats it!)

\*\*\*\*\*

## CHAPTER – 9 SPECIALTIES / COMMUNICATIONS + SECURITY

### Vocabulary

- **Communication Systems:** include intercoms, paging devices, sound systems, TV, CCTV, LAN and (most prevalent) telephone.
- **LAN:** a data communication system allowing a number of independent devices to communicate directly with each other and within a moderate sized area.

### TYPES OF COMMUNICATION SYSTEMS

#### Phone

- Fed through main cable connecting to rooms where they are split into riser cables;
- Risers are typically located near the core and connect at each floor;
- Multiple lines are supported by a phone switch;
- Each phone is connected to the switch via a copper cable;
- Phone switches can be small (up to 8 phone lines with 32 telephone connections), or large (hundreds of phone lines with thousands of extensions); and
- Large phone lines are called Private Branch Exchange or PBX and they can be expensive.

#### Data

- Typically used to describe a mainframe or minicomputer system, not the modern day LAN systems;
- Mainframe: a large centralized computer that performs all activities, computations and data storage; users interface through terminals; and
- Minicomputer: smaller version of mainframe computer, all applications run on centralized computer, but system is smaller and supports a few number of user terminals.

#### Local Area Networks (LAN)

- Designed to link personal computers together enabling them to communicate;
- Include computers, network interface card, communication cable, hubs/switches;
- Each station has to have a direct cable connection to a port on the hub;
- Building Automation and Control Systems (BACS);
- Regulate a building's environment or monitor it for safety or security;
- Use a centralized control unit and distributed sensors or devices; and
- Each sensor connects to a port on the centralized control.
- **Fire Alarm**
  - Controls the detection, suppression, and notification of fire;
  - Alarms are wired to a central port, when a signal is received the system can activate the fire suppression system and/or notify desired people;
  - Can integrate with security systems so normally secured doors can be opened for a safe evacuation;
  - Can link to the electrical system to provide emergency lighting or elevator capture during a fire/emergency

- **Security Systems**
  - Centralized control unity and Sensors & Magnetic Contact Points;
  - Smoke and heat, carbon monoxide, motion, water, freeze, doors/windows opening/breaking, personal emergency.
- **Access Control**
  - Includes a centralized control unit and access points;
  - Access points are connected to the control with cables, and open when user is verify by whatever desired method;
  - Includes: card readers, key pads, biometric sensors;
- **CCTV**
  - Video network for security;
  - Video cameras are placed throughout a building and campus and wired to TV monitors in a central security location.
- **Intercom**
  - Master stations in residential intercom systems differ from remote stations in that they allow selective calling.
- **Sound Systems**
  - Operates by converting sound waves into energy, increasing the power of the electrical energy using electronic circuitry, then converting the resulting electrical energy back into the form of sound waves;
  - Used for overhead paging and/or audio to broadcast information or music;
  - Components include: Sound source, Amplifier, Communication Cable, Speakers
  - In a two-channel sound system, the preamp would be located between the program selector and the distribution switch bank.

## SECURITY SYSTEMS

Intrusion detection is classified into three types: perimeter protection, area or room protection, and object protection

- **Perimeter Protection:** secures entry points (e.g.: doors, windows, ducts) to a space or building. Common types are:
  - **Magnetic contacts:** used on doors and windows, surface mounted or concealed.
  - **Glass Break Detectors:** metallic foils or vibration detectors mounted on glass.
  - **Window Screens:** embedded fine wires.
  - **Photoelectric Cells:** detection by beam or passing through an opening.
  - **Area/Room Protection:** field of coverage senses someone within a certain area where no one should be when activated.
  - **Photoelectric Beams:** pulsed infrared beam across a space, detects intrusion if beam is broken.
  - **Infrared Detectors:** unobtrusive, require a clear field of view of optimal protection. They sense sources of infrared radiation of the human body.
  - **Audio Detectors:** identify unusual sounds above normal level.
  - **Pressure Sensors:** detect weight on a floor or other surface.
  - **Ultrasonic Detectors:** emit a high frequency sound wave, but limited to an effective area of 20' x 30' and a height of 12'.
- **Object Protection:** sense movement or tampering of individual objects.

## ACCESS CONTROL

Access control can be provided by any of the following means:

- **Mechanical Lock:** It is a simplest and tractional form of security. Disadvantage is that duplicate keys can be made easily.
- **Card Readers:** It is a common electronic access control device. System can be programmed to control house of use, monitor car use through logs, and remove access code for card if lost or stolen.
- **Numbered Keypads:** It is a kind of unlocking a door by entering a numerical code. Eliminate the problem of keys with standard locks, but are not as flexible as magnetic pads.
- **Electric Lock:** It retracts the bolt when activated from the secure side of the door. Unlatching from inside is done by a button, switch, or mechanical retraction of a bolt by lever.
- **Biometric Devices:** It is a sophisticated and expensive method of security but provide counterfeit-proof method of identification and security. Read the individual biological features of a person (e.g.: iris/retina of the eye, fingerprint).
- **Retinal Scan:** A biometric technique that uses unique pattern of blood vessels at the back of the eye to validate the identity.
- **Iris Recognition:** An automatic biometric identification that uses recognition of the irises of an individual's eyes.

\*\*\*\*\*

**CHAPTER – 10**  
**MEP INTERFACE AND RELATIONSHIP WITH OTHER DISCIPLINES**

MEP is an engineering task comprising multiple systems, activities, and interfaces within various building trades. Architects must also be prepared to coordinate the work of multiple engineering specialties that will carry the environmental control systems concept forward through design development and beyond.

The building architecture and its integration to MEP services and civil construction may be evaluated in terms of eight (8) criteria, which can be bucketed in three levels of importance.

1.	Coordination with civil structural works	Coordination with civil structure works refers to the process of installing MEP, which must be well coordinated to embed the horizontal pipes beneath concrete structures and vertical sleeves in advance.	Level 1
2.	Safety	Safety refers to safety considerations during installation. For example, safety is required to prevent hazards such as a water pipe leakage if a water pipe lies above an electrical pipe.	
3.	Functionality	Functionality refers to ensuring that the function of pipes is fully exploited while complying with building codes. For example, drainage slopes and routes must be taken into consideration for proper drainage of waste water.	
4.	Constructability	Constructability is a second level requirement that involves the evaluation of installation difficulty and the arrangement of sequencing between MEP systems. It has a considerable influence on the planning, sequence, and progress of construction.	Level 2
5.	Economy	Economy refers to the cost estimates associated with MEP installation and integration with architecture, which can increase due to a lack of coordination. For instance, re-routing a pipeline or duct increases the lengths of the pipeline and associated costs.	Level 3
6.	Efficiency	Efficiency refers to the performance of MEP systems. For example, a lack of integration on plumbing can cause descending pressure and consuming capacity. Inadequate duct sizes for HVAC equipment can inhibit its performance and influence equipment functionality.	
7.	Expandability	Expandability refers to the future expansion or upgrade of facility and its influence on the MEP utilities.	
8.	Maintainability	Maintainability refers to the convenience of maintenance during the operation phase. Maintenance space and operation route must be taken into consideration.	

## COORDINATION WITH CIVIL STRUCTURE WORKS

Coordination with civil structure works refers to the process of installing MEP services.

Electrical raceways, conduits, HVAC ducts and plumbing pipes, and vertical sleeves of sewage pipes from the floor slab must be installed prior to slab grouting.

### Examples:

- Pre-bury and layout pipes on slabs.
- Embedded pipelines within the floor and sleeves should be completed prior to grouting.
- The concrete mat and foundation for equipment also should be clearly illustrated in accordance with the construction drawings.
- Openings on beams and partitions must match the pipe positions.
- Installation for outdoors's illumination lights, vents, fire hydrants must be consistent with civil construction.

### Safety

Safety refers to safety considerations during installation. For example, safety is required to prevent hazards such as a water pipe leakage if a water pipe lies above an electrical pipe.

### Examples:

- Separate high voltage transformer/distribution boxes from water pumps.
- Separate water pipes and electric conduits from telecommunication cables.
- Place electric conduits above water pipes to avoid water leaking.
- Distance sensors and vents to avoid sensing interference.
- The fire protection system is regulated by fire regulations and permit drawings; thus, the fire protection system should be constructed first to ensure the architecture construction drawings are in compliance.

### Functionality

Functionality refers to ensuring that the function of pipes is fully exploited while complying with building codes. For example, the design of life safety assessment and fire protection systems must be arranged prior to other systems in order to comply with fire codes and fire protection permit requirements.

### Examples:

- Comply with fire protection regulations for equipment.
- Separate fire protection pumps from generators.
- Isolate oxygen tanks within fire protected areas.
- Consider slopes for gravity drainages.
- Comply with fire protection regulations for pipes.
- Distance HVAC vents, intakes, fire protection sensors and sprinklers.



## Constructability

Constructability represents the factors influencing the sequence of installation. The conflicts can be categorized as follows:

- Conflict of equipment in a space: Because of the crowded space, the routing and sequence of installation for large equipment must be checked first.
- Conflict of pipeline in a space: Conditions for stacking and interlacing pipelines causes difficulty in installation and maintenance due to over-crowded spaces and lack of advance coordination.
- Crowded installation: Conflicts within the installation space, idle laborers, and poor installation quality can result from problems such as crowded spaces, or multiple workers operating simultaneously at a single site. Furthermore, the attitude of “first come first win” or “first do first win” causes conflict in the arrangement of pipelines.
- Pipe materials and dimensions: Installation suffers if the diameter of the pipe is oversized or if the material of the pipe is inflexible or too rigid to be easily cut or molded. If these kinds of materials are applied for the works, they should be installed earlier to prevent conflicts.
- Installation of pipeline tiers: When the pipeline layout exceeds two layers, pipes on the upper layer should be installed first.

### Examples:

- Consider movement circulation and space for large equipment layout.
- Maintain sufficient operation space.
- Avoid conflicts and multilayers overlap when pipelines space is not enough.
- Consider pipeline sizes and material flexibility.
- Install top layer pipelines first. Pipes with an oversized diameter and hard material should be placed at the uppermost level. HVAC ducts, smoke exhaust systems, and large main pipes in every system belong to this level.
- Check whether the terminal side equipment is obscured by other equipment that cause conflicts.
- Check ceiling heights and match ceiling horizontal layout.

## Economy

Economy refers to the cost estimates associated with integration, which can increase due to a lack of coordination. For example, piping should be laid out in a straight line covering the shortest possible distance to avoid bends and detours, and to conform to the principle of economy and energy benefit.

### Examples:

- Keep adequate distance among large equipment.
- Centralized equipment design is more economic than scattered formats.
- Equipment positions need to be close to load center.
- Apply shortest, closest route principle to pipeline layout.
- Keep adequate distance among terminal side equipment.
- Maintain consistency with ceilings or partition plans.

### Efficiency

Efficiency refers to a lack of integration causing descending pressure and consuming capacity, which influences the basic function of MEP systems.

#### Examples:

- Consider surrounding environmental factors and ventilation issues for major equipment.
- Straight pipes are preferable. Avoid curved pipes.
- Keep distance between HVAC vents and intakes.

### Expandability

Expandability refers to the lifecycle of the facility causing a demand for the expansion or upgrade of the facility.

#### Examples:

- Reserve space for future equipment expansion and possible flexible adjustments.
- Reserve space for future pipelines distribution.
- Consider reservation, disbanding flexible adjustments.

### Maintainability

Maintainability refers to the convenience of maintenance during the operation phase. Space for future expansion and maintenance should be reserved during the conceptual design phase.

#### Example:

- Consider maintenance and management of space and movement lines.

\*\*\*\*\*