



*An Online PDH Course  
brought to you by  
CEDengineering.com*

## **Liquid Process Piping**

### *Part 4: Double Containment and Lined Piping Systems*

Course No: M02-039  
Credit: 2 PDH

---

Elie Tawil, P.E., LEED AP

---



Continuing Education and Development, Inc.

P: (877) 322-5800  
[info@cedengineering.com](mailto:info@cedengineering.com)

*This course was adapted from the United States Army of Corps of Engineers (USACE), Publication Number EM 1110-1-4008, Chapters 8 and 9 of the "Liquid Process Piping" engineering manual, which is in the public domain.*

## Chapter 8 Double Containment Piping Systems

### 8-1. General

To date, the double containment piping system design has not been standardized. If possible, the use of double containment piping should be deferred until design and construction standards are published by a national standards organization, such as ASTM. An alternative to the factory designed secondary containment piping may be the use of single wall piping inside a sealed, watertight, 360-degree secondary containment barrier; refer to CEGS 11145, Aviation Fueling Systems. Due to the nature of the liquids transported in double containment piping systems, the primary standard for the design of these systems is the ASME B31.3, Chemical Plant and Petroleum Refinery Piping Code.

#### a. Regulatory Basis

Secondary containment is a means by which to prevent and detect releases to the environment. Therefore, when dealing with regulated substances in underground storage tank systems or when managing hazardous wastes, regulations typically require secondary containment of piping systems for new construction. Double wall piping systems are available to provide secondary containment. The double containment piping system is composed of an outer pipe that completely encloses an inner carrier pipe in order to detect and contain any leaks that may occur and to allow detection of such leaks.

Under storage tank regulation 40 CFR 280, secondary containment is required for tanks containing hazardous substances (as defined by CERCLA 101-14) or petroleum products. The requirement applies whenever 10% or more of the volume of the tank is underground. Tank standards in hazardous waste regulations in 40 CFR 264 and 40 CFR 265 also require secondary containment of piping systems. These requirements are not only applicable to RCRA Part B permitted treatment storage and disposal facilities, but also apply to interim status facilities and to generators accumulating waste in tanks with ancillary piping.

#### b. Design Requirements

Many options seem to exist for the combination of

different primary (carrier) and secondary (containment) piping systems based on physical dimensions. However, the commercial availability of components must be carefully reviewed for the selected materials of construction. Availability of piping sizes, both diameter and wall thickness; joining methods; and pressure ratings may preclude the combination of certain primary and secondary piping system materials.

In addition, some manufacturers offer “pre-engineered” double containment piping systems. Some of these systems may have been conceptualized without detailed engineering of system components. If specified for use, the detailed engineering of the “pre-engineered” system must be performed, including any required customizing, details, and code review.

#### c. Material Selection

For piping system material compatibility with various chemicals, see Appendix B. Material compatibility should consider the type and concentration of chemicals in the liquid, liquid temperature, and total stress of the piping system. The selection of materials of construction should be made by an engineer experienced in corrosion or similar applications. See Appendix A, Paragraph A-4 - Other Sources of Information, for additional sources of corrosion data.

Corrosion of metallic and thermoplastic piping systems was addressed in Paragraphs 4-2 and 5-1. However, it must be remembered that cracking, such as stress-corrosion cracking and environmental stress cracking, is a potentially significant failure mechanism in double containment piping systems. Differential expansion of inner and outer piping can cause reaction loads at interconnecting components. These loads can produce tensile stresses that approach yield strengths and induce stress cracking at the interconnection areas.

Material combinations may be classified into three main categories:

- (1) the primary and secondary piping materials are identical except for size, for example, ASTM A 53 carbon steel and A 53 carbon steel, respectively;
- (2) the primary and secondary piping are the same type of materials but not identical, for example, 316L stainless steel and A 53 carbon steel; and
- (3) different types of materials are used, for example,

PVDF as primary and A 53 carbon steel as secondary. Table 8-1 provides a further breakdown and description of these three groups.

d. Thermal Expansion

As discussed in the previous chapters, when a piping system is subjected to a temperature change, it expands or contracts accordingly. Double containment piping systems have additional considerations, including expansion-contraction forces occurring between two potentially different, interconnected piping systems. Thermal stresses can be significant when flexibility is not taken into account in the design. For a double containment piping system, the primary and secondary piping systems must be analyzed both as individual systems and as parts of the whole. The basic correlations between the systems are: (1) the primary piping system has a greater temperature change; and (2) the secondary piping system has a greater temperature change.

Because of the insulating effect of the secondary piping system, the primary piping system usually only exhibits a larger temperature induced change when the process dictates, for example, when a hot liquid enters the piping system. In both above grade and buried systems, secondary piping system expansions are typically compensated for with expansion loops, changes in direction, or a totally restrained system. Expansion joints are not recommended for this use due to potential leaks, replacement and maintenance, unless they can be located in a tank or vault.

To accommodate the dimensional changes of the primary piping system in expansion loops and change of direction elbows, secondary piping systems are often increased in size. Another alternative is to fully restrain the primary piping system. Figure 8-1 demonstrates the result of differential movement between the piping systems without full restraint, and Figure 8-2 depicts an expansion loop with an increase to the secondary piping diameter.

Totally restrained systems are complex. Stresses are induced at points of interconnection, at interstitial supports, and at other areas of contact. For rigid piping systems, restraints are placed at the ends of straight pipe

lengths and before and after complex fittings to relieve thermal stress and prevent fitting failure<sup>1</sup>. Plastic piping systems relieve themselves through deformation and wall relaxation, potentially leading to failure. Totally restrained systems should undergo a stress analysis and a flexibility analysis as part of the design.

The combined stress on the secondary piping system is the result of bending, as well as torsional, internal hydrostatic, and thermal expansion induced axial stresses. The following method, which assumes that internal hydrostatic and thermal expansion induced axial stresses approximate the total stress, can be used to determine whether a totally restrained design is suitable<sup>2</sup>:

$$S_c = \sqrt{(\sigma_{at})^2 + (\sigma_p)^2}$$

where:

- S<sub>c</sub> = combined stress, MPa (psi)
- σ<sub>at</sub> = thermal induced axial stress, MPa (psi)
- σ<sub>p</sub> = internal hydrostatic stress, MPa (psi)

$$\sigma_{at} = E \alpha \Delta T$$

where:

- σ<sub>at</sub> = thermal induced axial stress, MPa (psi)
- E = modulus of elasticity, MPa (psi)
- α = coefficient of thermal expansion, mm/mm/°C (in/in/°F)
- ΔT = differential between maximum operating and installation temperature, °C (°F)

$$\sigma_p = \frac{P (D_o - t)}{2 t}$$

where:

- σ<sub>p</sub> = internal hydrostatic stress, MPa (psi)
- P = liquid pressure, MPa (psi)
- D<sub>o</sub> = outside pipe diameter, mm (in)
- t = pipe wall thickness, mm (in)

<sup>1</sup> Schweitzer, Corrosion-Resistant Piping Systems, p. 417.

<sup>2</sup> Ibid., pp. 418-420.

**Table 8-1  
Double Containment Piping Material Combinations**

Category	Primary	Secondary	Comments	Common Materials
1	M	M	Used with elevated temperatures and/or pressures. Good structural strength and impact resistant. May be required by fire or building codes. Cathodic protection required if buried.	CS, 304 SS, 304L SS, 316 SS, 316L SS, 410 SS, Ni 200, Ni 201, Cu/Ni alloys
1	TS	TS	Common for above grade and buried use for organic, inorganic, and acid wastes/chemicals. Good chemical resistance and structural strength. Conductive to field fabrication.	polyester resin, epoxy resin, vinyl ester resin, furan resin
1	TP	TP	Easily joined and fabricated. Resistant to soil corrosion and many chemicals. May be restricted by fire/building codes. Impact safety may require safeguards.	PVC, CPVC, HDPE, PP, PVDF, ECTFE, ETFE, PFA
2	M	M	May be required by fire codes or mechanical properties. Galvanic actions must be controlled at crevices and interconnections. Cathodic protection required if buried.	CS-SS, Cu/Ni alloy - CS, CS-Ni, CS-410 SS
2	TS	TS	Not advisable to combine resin grades. Epoxy and polyester resins are most economical.	polyester-epoxy, vinyl ester-epoxy, vinyl ester-polyester
2	TP	TP	Common for above grade and buried acid/caustic use. Economical - many commercial systems are available.	Many - PVDF-PP, PVDF-HDPE, PP-HDPE
3	M	TS	Common and economical. Practical - interconnections have been developed. Good for buried use, may eliminate cathodic protection requirements.	epoxy-M (CS, SS, Ni, Cu), polyester-M (CS, SS, Ni, Cu)
3	M	TP	Common and economical. Good for buried use, may eliminate cathodic protection requirements. May be limited by fire or building codes.	HDPE - M (CS, SS), PVDF- M (CS, SS), PP-M (CS, SS)
3	M	O	Limited practical use except for concrete trench. Ability for leak detection is a concern.	concrete trench - M
3	TS	M	Common for above grade systems requiring thermoset chemical resistance and metallic mechanical properties. Can meet category "M" service per ASME code.	many
3	TS	TP	Economical. Good for buried applications.	epoxy-TP (HDPE, PVC, PP), polyester-TP (HDPE, PVC, PP)
3	TS	O	Limited practical use except for concrete trench. Ability for leak detection is a concern.	concrete trench - TS
3	TP	M	Common for above grade systems requiring thermoset chemical resistance and metallic mechanical properties. Can meet category "M" service per ASME code.	many
3	TP	TS	Limited in use - thermoplastic chemical resistance needed with thermoset mechanical properties. May not meet UL acceptance standards.	limited
3	TP	O	Limited practical use except for concrete trench or pipe. Ability for leak detection is a concern.	concrete trench - TP, concrete pipe - PVC
3	O	M	Interconnections may be difficult. Good for protection of brittle materials.	CS-glass, CS-clay

Notes: The primary piping material is listed first on primary-secondary combinations. Material designations are: M - metallic materials; TS - thermoset materials; TP - thermoplastic materials; and O - other nonmetallic materials  
Source: Compiled by SAIC, 1998.

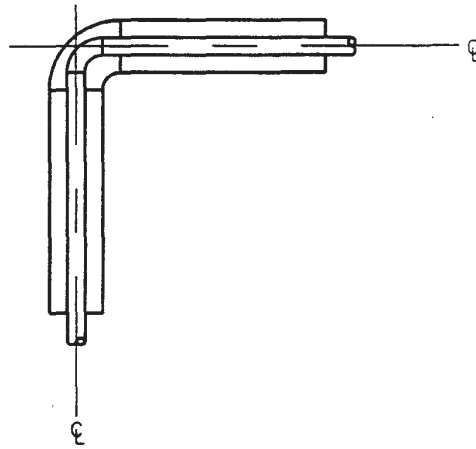

a. Before Thermal Expansion

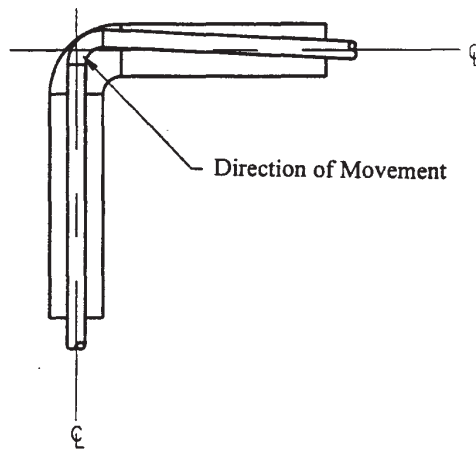

b. After Thermal Expansion

Figure 8-1. Primary Piping Thermal Expansion  
(Source: SAIC, 1998)

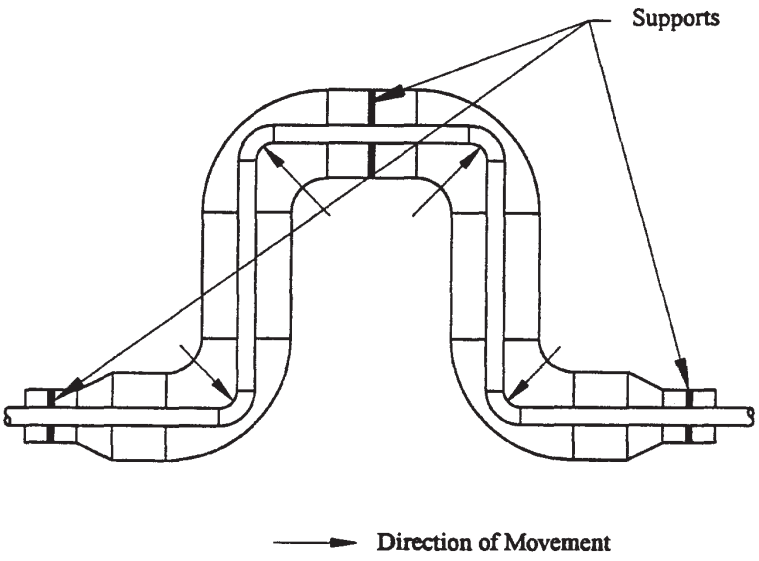

Figure 8-2. Double Containment Piping Expansion Loop Configuration  
(Source: SAIC, 1998)

If the value of the combined stress,  $S_c$ , is less than the design stress rating of the secondary piping material, then the totally restrained design can be used.

When double containment piping systems are buried, and the secondary piping system has a larger temperature change than the primary system, the ground will generally provide enough friction to prevent movement of the outer pipe. However, if extreme temperature differentials are expected, it may be necessary to install vaults or trenches to accommodate expansion joints and loops.

For double containment systems located above grade, with secondary piping systems that have a larger temperature differential than primary systems, two common solutions are used. First, expansion joints in the outer piping can accommodate the movement. Second, the secondary piping can be insulated and heat traced to reduce the potential expansion-contraction changes. The latter would be particularly effective with processes that produce constant temperature liquids; therefore, the primary piping is relatively constant.

#### e. Piping Support

Support design for double containment piping systems heeds the same guidelines as for the piping material used to construct the containment system. The support design is also based on the outside (containment) pipe size. Spans for single piping systems of the same material as the outer pipe may be used. The same recommendations may be applied for burial of double containment piping systems as for the outer containment pipe material.

The following equation approximates the maximum spacing of the secondary piping system guides, or interstitial supports. The maximum guide spacing should be compared to the maximum hanger spacing (at maximum operating temperature) and the lesser distance used. However, the flexibility of the system should still be analyzed using piping stress calculations to demonstrate that elastic parameters are satisfied<sup>3</sup>.

$$l_g = \left( \frac{48 f E I}{4 Z S_c} \right)^{0.5}$$

where:

- $l_g$  = maximum span between guides, mm (in)
- $f$  = allowable sag, mm (in)
- $E$  = modulus of elasticity, MPa (psi)
- $I$  = moment of inertia, mm<sup>4</sup> (in<sup>4</sup>)
- $Z$  = section modulus, mm<sup>3</sup> (in<sup>3</sup>)
- $S_c$  = combined stress, MPa (psi)

## 8-2. Piping System Sizing

The method for sizing of the carrier pipe is identical to the methods required for single wall piping systems; see previous chapters.

### a. Secondary Pipe

Secondary piping systems have more factors that must be considered during sizing. These factors include secondary piping function (drain or holding), pressurized or non-pressurized requirements, fabrication requirements, and type of leak detection system. The assumption has to be made that at some point the primary piping system will leak and have to be repaired, thus requiring the capability to drain and vent the secondary piping system. Most systems drain material collected by the secondary piping system into a collection vessel. Pressurized systems, if used, are generally only used with continuous leak detection methods, due to the required compartmentalization of the other leak detection systems.

Friction loss due to liquid flow in pressurized secondary piping systems is determined using the standard equations for flow in pipes with the exception that the hydraulic diameter is used, and friction losses due to the primary piping system supports have to be estimated. The hydraulic diameter may be determined from:

$$D_h = d_i - D_o$$

where:

- $D_h$  = hydraulic diameter, mm (in)
- $d_i$  = secondary pipe inside diameter, mm (in)
- $D_o$  = primary pipe outside diameter, mm (in)

---

<sup>3</sup> Schweitzer, Corrosion-Resistant Piping Systems, p. 420.



In addition, for double containment piping systems that have multiple primary pipes inside of a single secondary piping system, pressurized flow parameters can be calculated using shell and tube heat exchanger approximations ( for more information, refer to the additional references listed in Paragraph A-4 of Appendix A).

**8-3. Double Containment Piping System Testing**

The design of double containment piping systems includes the provision for pressure testing both the primary and secondary systems. Testing is specified in the same manner as other process piping systems. The design of each piping system contains the necessary devices required for safe and proper operation including pressure relief, air vents, and drains.

Pressurized secondary piping systems are equipped with pressure relief devices, one per compartment, as appropriate. Care should be taken with the placement of these devices to avoid spills to the environment or hazards to operators.

Low points of the secondary piping system should be equipped with drains, and high points should be equipped with vents. If compartmentalized, each compartment must be equipped with at least one drain and one vent. Drains and vents need to be sized to allow total drainage of liquid from the annular space that may result from leaks or flushing. The following equations can be used for sizing<sup>4</sup>:

Step 1. Drainage Flow through Drain.

$$t = \int \frac{A_a}{C_d A_D \sqrt{2 g h}} dh, \text{ for } h_1 - h_2$$

where:

- t = time, s
- A<sub>a</sub> = annular area, m<sup>2</sup> (ft<sup>2</sup>)
- C<sub>d</sub> = C<sub>c</sub>C<sub>v</sub>
- C<sub>c</sub> = coefficient of contraction, see Table 8-2
- C<sub>v</sub> = coefficient of velocity, see Table 8-2
- A<sub>D</sub> = area of drain opening, m<sup>2</sup> (ft<sup>2</sup>)
- g = gravitational acceleration, 9.81 m/s<sup>2</sup> (32.2 ft/s<sup>2</sup>)
- h = fluid head, m (ft)

Step 2. Flushing Flow through Drain.

$$t = \int \frac{A_a}{[(C_d A_D \sqrt{2 g h}) - Q_f]} dh, \text{ for } h_1 - h_2$$

where:

- Q<sub>f</sub> = flushing liquid flow rate, m<sup>3</sup>/s (ft<sup>3</sup>/s)
- t = time, s
- A<sub>a</sub> = annular area, m<sup>2</sup> (ft<sup>2</sup>)
- C<sub>d</sub> = C<sub>c</sub>C<sub>v</sub>
- C<sub>c</sub> = coefficient of contraction, see Table 8-2
- C<sub>v</sub> = coefficient of velocity, see Table 8-2
- A<sub>D</sub> = area of drain opening, m<sup>2</sup> (ft<sup>2</sup>)
- g = gravitational acceleration, 9.81 m/s<sup>2</sup> (32.2 ft/s<sup>2</sup>)
- h = fluid head, m (ft)

Table 8-2 Common Orifice Coefficients		
Condition	C <sub>v</sub>	C <sub>c</sub>
Short tube with no separation of fluid flow from walls	0.82	1.00
Short tube with rounded entrance	0.98	0.99
Source: Reprinted from Schweitzer, <u>Corrosion-Resistant Piping Systems</u> , p. 414, by courtesy of Marcel Dekker, Inc.		

<sup>4</sup> Schweitzer, Corrosion-Resistant Piping Systems, pp. 414-415.

#### 8-4. Leak Detection Systems

Leak detection is one of the main principles of double containment piping systems. Any fluid leakage is to be contained by the secondary piping until the secondary piping can be drained, flushed, and cleaned; and the primary piping system failure can be repaired. Without leak detection, the potential exists to compromise the secondary piping system and release a hazardous substance into the environment. Early in the design of a double containment piping system, the objectives of leak detection are established in order to determine the best methods to achieve the objectives. Objectives include:

- need to locate leaks;
- required response time;
- system reliability demands; and
- operation and maintenance requirements.

##### a. Cable Leak Detection Systems

Cable detection systems are a continuous monitoring method. The purpose of this method is to measure the electrical properties (conductance or impedance) of a cable; when properties change, a leak has occurred. These systems are relatively expensive compared to the other methods of leak detection. Many of the commercially available systems can determine when a leak has occurred, and can also define the location of the leak. Conductance cable systems can detect the immediate presence of small leaks, and impedance systems can detect multiple leaks. However, it must be remembered that these types of systems are sophisticated electronic systems and that there may be problems with false alarms, power outages, and corroded cables<sup>5</sup>. Design requirements for these systems include: access, control panel uninterruptible power supply (UPS), and installation requirements.

Access ports should be provided in the secondary piping system for installation and maintenance purposes. The ports should be spaced similar to any other electrical wiring:

- at the cable entry into and exit from each pipe run;
- after every two changes in direction;
- at tee branches and lateral connections;
- at splices or cable branch connections; and
- after every 30.5 m (100 feet) of straight run.

Power surges or temporary outages will set off alarms. To avoid such occurrences, consideration should be given to UPS.

Installation requirements for a cable system include the completing of testing and thorough cleaning and drying of the secondary piping system prior to installation to avoid false alarms. In addition, a minimum annular clearance of 18 mm (3/4 in) for conductance cables and 38 to 50 mm (1-1/2 to 2 inches) for impedance cables is required to allow installation. These values may vary between manufacturers.

##### b. Probe Systems

Probes that measure the presence of liquids through conductivity, pH, liquid level, moisture, specific ion concentrations, pressure, and other methods are used as sensing elements in leak detection systems. The double containment piping systems are separated into compartments with each compartment containing a probe with probe systems. Leaks can only be located to the extent to which the compartment senses liquid in the secondary containment piping.

##### c. Visual Systems

Visual systems include the use of sumps and traps; installation of sight glasses into the secondary piping system; equipping the secondary piping system with clear traps; and use of a clear secondary piping material. Some manufacturers offer clear PVC. Visual systems are often used in addition to other leak detection methods.

---

<sup>5</sup> Schweitzer, Corrosion-Resistant Piping Systems, p. 412.

## Chapter 9 Lined Piping Systems

### 9-1. General

When properly utilized, a lined piping system is an effective means by which to protect metallic piping from internal corrosion while maintaining system strength and external impact resistance. Cathodic protection is still required for buried applications to address external corrosion. Manufacturing standard options for the outer piping material are usually Schedule 40 or 80 carbon steel. Lined piping systems are not double containment piping systems.

#### a. Design Parameters

Design factors that must be taken into account for the engineering of lined piping systems include: pressure, temperature and flow considerations; liner selection factors of permeation, absorption, and stress cracking; and heat tracing, venting and other installation requirements.

#### b. Operating Pressures and Temperatures

The requirements for addressing pressure and temperature conditions for lined piping systems are summarized in the following paragraphs.

Lined piping systems are used primarily for handling corrosive fluids in applications where the operating pressures and temperatures require the mechanical strength of metallic pipe. Therefore, the determination of maximum steady state design pressure is based on the same procedure and requirements as metallic pipe shell, and the design temperature is based on similar procedures and requirements as thermoplastic pipe.

Table 9-1 lists recommended temperature limits of thermoplastic used as liners. The temperature limits are based on material tests and do not necessarily reflect evidence of successful use as piping component linings in specific fluid serviced at the temperatures listed. The manufacturer is consulted for specific application limitations.

#### c. Liner Selection

Liner selection for piping systems must consider the materials being carried (chemical types and concentrations, abrasives, flow rates), the operating conditions (flow, temperature, pressure), and external situations (high temperature potential).

For the material compatibility of metallic lined piping system with various chemicals, see Appendix B. As discussed in Chapter 4, metallic material compatibility should consider the type and concentration of chemicals

Table 9-1 Thermoplastic Liner Temperature Limits (Continuous Duty)				
Materials	Recommended Temperature Limits			
	Minimum		Maximum	
	°F	°C	°F	°C
ECTFE	-325	-198	340	171
ETFE	-325	-198	300	149
FEP	-325	-198	400	204
PFA	-325	-198	500	260
PP	0	-18	225	107
PTFE	-325	-198	500	260
PVDC	0	-18	175	79
PFDF	0	-18	275	135

Note: Temperature compatibility should be confirmed with manufacturers before use is specified.  
Source: ASME B31.3, p. 96, Reprinted by permission of ASME.

in the liquid, liquid temperature and total stress of the piping system. The selection of materials of construction should be made by an engineer experienced in corrosion or similar applications. See Appendix A, Paragraph A-4, for additional sources of corrosion data.

As discussed in Chapter 5, thermoplastic materials do not display corrosion rates and are, therefore, either completely resistant to a chemical or will rapidly deteriorate. Plastic lined piping system material failure occurs primarily by the following mechanisms: absorption, permeation, environmental-stress cracking, and combinations of the above mechanisms.

Permeation of chemicals may not affect the liner but may cause corrosion of the outer metallic piping. The main design factors that affect the rate of permeation include absorption, temperature, pressure, concentration, and liner density and thickness. As temperature, pressure, and concentration of the chemical in the liquid increase, the rate of permeation is likely to increase. On the other hand, as liner material density and thickness increase, permeation rates tend to decrease<sup>1</sup>.

For plastic material compatibility with various chemicals, see Appendix B. See Appendix A, Paragraph A-4, for additional sources of corrosion data. For the material compatibility of elastomeric and rubber as well as other nonmetallic material lined piping systems with various chemicals, see appendix B.

Liners should not be affected by erosion with liquid velocities of less than or equal to 3.66 m/s (12 ft/s) when abrasives are not present. If slurries are to be handled, lined piping is best used with a 50% or greater solids content and liquid velocities in the range of 0.61 to 1.22 m/s (2 to 4 ft/s). Particle size also has an effect on erosion. Significant erosion occurs at >100 mesh; some erosion occurs at >250 but <100 mesh; and little erosion occurs at <250 mesh. Recommended liners for slurry applications are PVDF and PTFE, and soft rubber; by comparison, in a corrosive slurry application, PP erodes 2 times as fast and carbon steel erodes 6.5 times as fast<sup>2</sup>.

#### d. Joining

Two available methods for joining lined pipe are flanged joints and mechanical couplings (in conjunction with heat fusion of the thermoplastic liners).

Thermoplastic spacers are used for making connections between lined steel pipe and other types of pipe and equipment. The spacer provides a positive seal. The bore of the spacer is the same as the internal diameter ( $D_i$ ) of the lined pipe. Often, a gasket is added between the spacer and a dissimilar material to assist in providing a good seal and to protect the spacer.

When connecting lined pipe to an unlined flat face flange, a 12.7 mm ( $\frac{1}{2}$  in) thick plastic spacer of the same material as the pipe liner is used. A gasket and a spacer will connect to an unlined raised face flange. Both a gasket and a spacer is recommended to connect to glass-lined equipment nozzles. Install a 12.7 mm ( $\frac{1}{2}$  in) thick spacer between lined pipe or fittings and other plastic-lined components, particularly valves, if the diameters of the raised plastic faces are different.

For small angle direction changes, tapered face spacers may be used<sup>3</sup>. It is not recommended to exceed a five degree directional change using a tapered face spacer. For directional changes greater than five degrees, precision-bent fabricated pipe sections are available from lined pipe manufacturers.

Gaskets are not necessary to attain a good seal between sections of thermoplastic lined pipe, if recommended fabrication and installation practices are followed. Often, leaks result from using insufficient torque when trying to seal a joint. The addition of a gasket provides a softer material which seals under the lesser stress developed by low torque. When gaskets or any dissimilar materials are used in the pipe joint, the lowest recommended torque for the materials in the joint is always used.

Gaskets are put in when previously used lined pipe is reinstalled following maintenance. Gaskets are also used between plastic spacers and non-plastic-lined pipe, valves, or fittings.

---

<sup>1</sup> Schweitzer, Corrosion-Resistant Piping Systems, pp.149-151.

<sup>2</sup> Ibid., p. 153.

<sup>3</sup> Crane/Resistoflex, "Plastic Lined Piping Products Engineering Manual," p. 41.

The recommended bolt torque values for thermoplastic lined piping systems are shown on Tables 9-2 through 9-5. Excessive torque causes damage to the plastic sealing surfaces. When bolting together dissimilar materials, the lowest recommended torque of the components in the joint is used.

Bolting torque is rechecked approximately 24 hours after the initial installation or after the first thermal cycle. This is required to reseal the plastic and allow for relaxation of the bolts. Bolting is performed only on the system in the ambient, cooled state, and never while the process is at elevated temperature or excessive force could result upon cooling.

#### e. Thermal Expansion

Thermal expansion design for lined piping systems can be handled in a similar manner as metallic piping. Expansion joints have been used to compensate for thermal expansion. However, expansion joints are usually considered the weakest component in a piping system and are usually eliminated through good engineering practices. Due to the bonding between the liner and the metallic pipe casing, pre-manufactured sections of pipe designed to allow for changes in movement of the piping system are available from manufacturers.

On long straight pipe runs, lined pipe is treated similarly to carbon steel piping. Changes in direction in pipe runs are introduced wherever possible to allow thermal expansion.

A common problem is the installation of lined piping between a pump and another piece of equipment. On new installations, equipment can be laid out such that there are no direct piping runs. Where a constricted layout is required or a piping loop would not be practical, the solution is to allow the pump to "float." The pump-motor base assemblies are mounted on a platform with legs. These bases are available from several manufacturers or can be constructed. These bases allow movement in order to relieve the stresses in the piping system.

#### f. Heat Tracing and Insulation

Heat tracing, insulation, and cladding can be installed on lined piping systems when required. The key for the design is to not exceed the maximum allowable temperature of the lining. Manufacturers recommendations on electrical heat tracing design should be followed to avoid localized hot spots. Steam heat tracing should not be used with most plastic lined piping systems due to the high temperature potential. Venting is required on many lined piping systems to allow for permeating vapor release. If insulation or cladding is to be mounted on the piping system, vent extenders should be specified to extend past the potential blockage.

#### g. Piping Support and Burial

Design of support systems for lined piping systems follows the same guidelines as for the outer piping material. Spans for systems consisting of the material used in the outer pipe may be used. Supports should permit the pipe to move freely with thermal expansion and contraction. The design requirements for buried lined piping systems are the same as those for the outer piping material. That is, a buried plastic lined carbon steel pipe should be treated the same way as a carbon steel pipe without a liner.

### 9-2. Plastic Lined Piping Systems

Thermoplastic lined piping systems are commonly used and widely available commercially under a variety of trade names. Table 9-6 presents a summary of some of the material properties for plastic liners, and Table 9-7 lists some of the liner thicknesses used for the protection of oil production equipment when applied as a liquid coating. Standard liner thicknesses are 3.3 to 8.6 mm (0.130 to 0.340 inches).

#### a. Common Plastic Liners

Most thermoplastics can be used as liner material. However, the more common and commercially available plastic liners include polyvinylidene chloride, perfluoroalkoxyl, polypropylene, polytetrafluoroethylene, and polyvinylidene fluoride.

<b>Table 9-2 ANSI Class 125 and Class 150 Systems (Lightly Oiled Bolting)</b>						
<b>Pipe Size, mm (in)</b>	<b>Number of Bolts</b>	<b>Bolt Diameter mm (in)</b>	<b>Bolt Torque, N-m (ft-lb)</b>			
			<b>PVDC</b>	<b>PP</b>	<b>PVDF</b>	<b>PTFE</b>
25 (1)	4	14 (½)	41 (30)	37 (35)	75 (55)	34 (25)
40 (1½)	4	14 (½)	54 (40)	102 (75)	81 (60)	75 (55)
50 (2)	4	16 (5/8)	61 (45)	149 (110)	169 (125)	102 (75)
65 (2½)	4	16 (5/8)	75 (55)	169 (125)	N.A.	N.A.
80 (3)	4	16 (5/8)	95 (70)	169 (125)	169 (125)	149 (110)
100 (4)	8	16 (5/8)	68 (50)	190 (140)	169 (125)	129 (95)
150 (6)	8	20 (¾)	129 (95)	305 (225)	305 (225)	169 (125)
200 (8)	8	20 (¾)	217 (160)	305 (225)	305 (225)	258 (190)
250 (10)	12	24 (7/8)	N.A.	468 (345)	N.A.	271 (200)

Notes: These torques are only valid for lightly oiled ASTM A 193 bolts and nuts. Lightly oiled is considered WD-40 (WD-40 is a registered trademark of WD-40 Company, San Diego, CA) or equivalent.  
N.A. = Part is not available from source.

Source: Crane/Resistoflex, "Plastic Lined Piping Products Engineering Manual," p. 54.

<b>TABLE 9-3 ANSI Class 300 Systems (Lightly Oiled Bolting)</b>						
<b>Pipe Size mm (in)</b>	<b>Number of Bolts</b>	<b>Bolt Diameter mm (in)</b>	<b>Bolt Torque, N-m (ft-lb)</b>			
			<b>PVDC</b>	<b>PP</b>	<b>PVDF</b>	<b>PTFE</b>
25 (1)	4	16 (5/8)	37 (35)	61 (45)	95 (70)	41 (30)
40 (1½)	4	16 (5/8)	81 (60)	149 (110)	230 (170)	108 (80)
50 (2)	8	16 (5/8)	34 (25)	75 (55)	115 (85)	54 (40)
80 (3)	8	20 (¾)	54 (40)	136 (100)	210 (155)	88 (65)
100 (4)	8	20 (¾)	81 (60)	230 (170)	305 (225)	149 (110)
150 (6)	12	20 (¾)	88 (65)	224 (165)	305 (225)	115 (85)
200 (8)	12	24 (7/8)	169 (125)	441 (325)	495 (365)	203 (150)

Note: These torques are only valid for lightly oiled ASTM A 193, B7 bolts and ASTM A 194, 2H nuts. Lightly oiled is considered WD-40 (WD-40 is a registered trademark of WD-40 Company, San Diego, CA) or equivalent.

Source: Crane/Resistoflex, "Plastic Lined Piping Products Engineering Manual," p. 54.

<b>Table 9-4</b> <b>ANSI Class 125 and Class 150 Systems</b> <b>(Teflon - Coated Bolting)</b>						
<b>Pipe Size, mm (in)</b>	<b>Number of Bolts</b>	<b>Bolt Diameter mm (in)</b>	<b>Bolt Torque N-m (ft-lb)</b>			
			<b>PVDC</b>	<b>PP</b>	<b>PVDF</b>	<b>PTFE</b>
25 (1)	4	14 (½)	27 (20)	34 (25)	54 (40)	20 (15)
40 (1½)	4	14 (½)	41 (30)	75 (55)	61 (45)	54 (40)
50 (2)	4	16 (5/8)	41 (30)	95 (70)	122 (90)	68 (50)
65 (2½)	4	16 (5/8)	37 (35)	122 (90)	N.A.	N.A.
80 (3)	4	16 (5/8)	68 (50)	122 (90)	122 (90)	95 (70)
100 (4)	8	16 (5/8)	37 (35)	122 (90)	122 (90)	81 (60)
150 (6)	8	20 (¾)	41 (30)	102 (75)	102 (75)	68 (50)
200 (8)	8	20 (¾)	75 (55)	102 (75)	102 (75)	102 (75)
250 (10)	12	24 (7/8)	N.A.	339 (250)	N.A.	203 (150)
300 (12)	12	24 (7/8)	N.A.	339 (250)	N.A.	271 (200)

Notes: These torques are valid only for Teflon-coated ASTM A 193, B7 bolts and ASTM A 194, 2H nuts.  
N.A. = Part is not available from source.

Source: Crane/Resistoflex, "Plastic Lined Piping Products Engineering Manual," p. 55.

<b>TABLE 9-5</b> <b>ANSI Class 300 Systems</b> <b>(Teflon - Coated Bolting)</b>						
<b>Pipe Size mm (in)</b>	<b>Number of Bolts</b>	<b>Bolt Diameter mm (in)</b>	<b>Bolt Torque N-m (ft-lb)</b>			
			<b>PVDC</b>	<b>PP</b>	<b>PVDF</b>	<b>PTFE</b>
25 (1)	4	16 (5/8)	41 (30)	37 (35)	61 (45)	27 (20)
40 (1½)	4	20 (¾)	34 (25)	61 (45)	95 (70)	41 (30)
50 (2)	8	16 (5/8)	27 (20)	61 (45)	95 (70)	41 (30)
80 (3)	8	20 (¾)	34 (25)	61 (45)	81 (60)	34 (25)
100 (4)	8	20 (¾)	41 (30)	95 (70)	102 (75)	61 (45)
150 (6)	12	20 (¾)	41 (30)	95 (70)	102 (75)	37 (35)
200 (8)	12	24 (7/8)	129 (95)	312 (230)	346 (255)	163 (120)

Notes: These torques are valid only for Teflon-coated ASTM A 193, B7 bolts and ASTM A 194, 2H nuts.

Source: Crane/Resistoflex, "Plastic Lined Piping Products Engineering Manual," p. 55.

<b>Table 9-6 Plastic Liner Material Properties</b>					
<b>Liner Material</b>	<b>Shell Material</b>	<b>Specific Gravity</b>	<b>Tensile Strength, MPa (psi)</b>	<b>Available Size Range, mm (in)</b>	<b>Maximum Temperature, °C (°F)</b>
PVC	--	1.45	41.4 (6,000)	--	82 (180)
PVDC	carbon steel	1.75	18.6 (2,700)	25 to 200 (1 to 8)	79 (175)
PE	carbon steel, aluminum	0.94	8.27 (1,200)	50 to 200 (2 to 8)	66 (150)
PP	carbon steel	0.91	31.0 (4,500)	25 to 300 (1 to 12)	107 (225)
PTFE	carbon steel, TP304L stainless steel	2.17	17.2 (2,500)	25 to 300 (1 to 12)	232 (450)
FEP	carbon steel	2.15	23.4 (3,400)	25 to 750 (1 to 30)	204 (400)
PFA	carbon steel	2.15	24.8 (3,600)	25 to 750 (1 to 30)	260 (500)
ETFE	carbon steel	1.7	44.8 (6,500)	as required*	150 (300)
PVDF	carbon steel	1.78	31.0 (4,500)	25 to 200 (1 to 8)	135 (275)
ECTFE	carbon steel, stainless steel	1.68	48.3 (7,000)	25 to 200 (1 to 8)	150 (300)

Note: \*Typically liquid applied; availability based upon shell piping availability.  
Source: Compiled by SAIC, 1998; note that confirmation is required from the specific vendor for a selected product.

<b>Table 9-7 Liquid-Applied Coating Thickness</b>	
<b>Material</b>	<b>Total Dry Film Thickness Range</b>
Fluoropolymers (ETFE, ECTFE)	50 to 125 µm (2 to 5 mils)
PVDF	500 to 1,500 µm (20 to 60 mils)

Source: NACE, RP 0181-94, p. 3.



Polytetrafluoroethylene (PTFE) is a fully fluorinated polymer. Although PTFE is chemically inert to most materials, some chemicals will permeate through the liner. Therefore, venting of the joint area between the liner and outer casing is required<sup>4</sup>. PTFE materials are produced in accordance with ASTM D 1457 with material parameters specified by the designation of type (I through VIII) and class (specific to each type). The manufacture of PTFE lined pipe and materials are in accordance with ASTM F 423.

Polyvinylidene fluoride (PVDF) is similar to PTFE but is not fully fluorinated. PVDF liners can be produced with sufficient thickness to prevent permeation of gases (see Table 9-8) so that liner venting is not required<sup>5</sup>. PVDF resins are produced in accordance with ASTM D 3222 with material parameters specified by the designation of either type 1 (class 1 or 2) or type 2. PVDF lined pipe and fittings are manufactured to conform to ASTM F 491.

Polyvinylidene chloride (PVDC) is a proprietary product of Dow Chemical (trade name Saran). PVDC is often used in applications where purity protection is critical. PFA resins are manufactured according to ASTM D 729, and lined piping and fittings are manufactured to conform to ASTM F 599.

Polypropylene (PP) lined pipe is typically inexpensive compared to other lined plastic piping systems. In addition, PP does not allow permeation; therefore, liner venting is not required<sup>6</sup>. Physical parameters (e.g., density, tensile strength, flexural modulus) of PP materials are specified by cell classification pursuant to ASTM D 4101. Additional material requirements may be added using the ASTM D 4000 suffixes; for example, W = weather resistant. The manufacture of PP lined pipe and materials are in accordance with ASTM F 492.

Perfluoroalkoxyl (PFA) is a fully fluorinated polymer that is not affected by chemicals commonly found in chemical processes. Depending upon process conditions PFA will absorb some liquids, however, including benzaldehyde,

carbon tetrachloride, toluene, ferric chloride, hydrochloric acid, and other liquids. PFA lacks the physical strength of PTFE at higher temperatures and fails at 1/4 of the life of PTFE under flexibility tests<sup>7</sup>. PFA resins are manufactured according to ASTM D 3307, and lined piping and fittings are manufactured to conform to ASTM F 781.

<b>Table 9-8 Typical PVDF Liner Thickness Required to Prevent Permeation</b>	
<b>Nominal Pipe Size, mm (in)</b>	<b>Liner Thickness, mm (in)</b>
25 (1)	3.81 (0.150)
40 (1 ½)	4.07 (0.160)
50 (2)	4.37 (0.172)
80 (3)	4.45 (0.175)
100 (4)	5.26 (0.207)
150 (6)	5.54 (0.218)
200 (8)	5.54 (0.218)
Source: Reprinted from Schweitzer, <u>Corrosion-Resistant Piping Systems</u> , p. 182, by courtesy of Marcel Dekker, Inc.	

b. Plastic Lined Piping Construction

As discussed in Paragraph 9-1d, plastic lined pipe piping is joined using flanges or mechanical couplings and fittings that are normally flanged. Some manufacturers can provide pre-bent pipe sections to avoid the use of flanged elbows. Use of pre-bent pipe sections requires

<sup>4</sup> Schweitzer, Corrosion-Resistant Piping Systems, pp. 161-162.  
<sup>5</sup> Ibid., p. 165.  
<sup>6</sup> Ibid., p. 166.  
<sup>7</sup> Ibid., p. 164.

that the design take into account the manufacturer's standard bend radius which is often larger than the bend radius for conventional elbows.

### 9-3. Other Lined Piping Systems

The elastomer and rubber materials most commonly used as liner materials include natural rubber, neoprene, butyl, chlorobutyl, nitrile, and EPDM, which tend to be less expensive than other liners. Design criteria that need to be considered before selecting elastomeric and rubber lined piping systems include: corrosion resistance, abrasion resistance, maximum operating temperature, and potential contamination of conveyed material.

Elastomeric and rubber linings vary in thickness from 3.2 to 6.4 mm (1/8 to 1/4 in). Lined pipe is available from 40 to 250 mm (1½ to 10 in), standard, at ratings of 1.03

MPa (150 psi) or 2.06 MPa (300 psi). Joining is typically accomplished through the use of flanges.

Glass-lined piping systems are commercially available with carbon steel outer piping in sizes of 25 to 300 mm (1 to 12 in), standard. Joining is accomplished using class 150 split flanges, although class 300 split flanges are also available as options. A PTFE envelope gasket is recommended<sup>8</sup>. Stress is to be avoided; expansion joints should be used to isolate vibration and other stresses from the piping system. Sudden changes in process temperatures should also be avoided.

Nickel-lined piping systems are available in sizes from 40 to 600 mm (1½ to 24 in) with liner thickness of 0.0008 to 0.015 inches. Joining is accomplished either by welding or flanging, with welding the preferred method<sup>9</sup>.

---

<sup>8</sup> Schweitzer, Corrosion-Resistant Piping Systems, p. 198.

<sup>9</sup> Ibid., p. 199.