Low Voltage Switchgear

Course No: E03-039

Credit: 3 PDH

Velimir Lackovic, Char. Eng.



Continuing Education and Development, Inc.
22 Stonewall Court
Woodcliff Lake, NJ 07677

P: (877) 322-5800
info@cedengineering.com

LOW VOLTAGE SWITCHGEAR

Low-voltage switchgear is typically used name for metal-enclosed or metal-clad low-voltage power circuit breaker switchgear rated for 600V alternating current (AC) and below. The metal-enclosed switchgear is completely enclosed on all sides and top with metal sheets and has stationary primary power circuit switching or interrupting elements, or both, with buses and connections. The metal-clad low-voltage switchgear has removable circuit breakers which are housed in individual earthed metal compartments. There are two basic low-voltage switchgear types. They are indoor and outdoor types. Indoor switchgear consists of a front section containing circuit breakers, meters, protection relays and controls, bus section, and cable entrance section. The outdoor section is similar to the indoor switchgear except a structure that is provided around it for weather-proofing. Bus bars can be made of copper or aluminum. Typically, bare bus bars are used. Nevertheless, insulation can be specified on special orders. The normal clearance between line to line and line to ground is 2 in. to minimize creepage for 600 V rated equipment. The standard high-voltage withstand is 2200 V AC for line to line and line to ground for a period of 1 min. Low-voltage switchgear takes on many specific forms and functions that combine metering, monitoring, control, protection, and distribution. Original equipment manufacturers (OEMs) now provide a wide variety of low-voltage switchgear arrangements, some of them very custom, to meet the user's requirements. It is frequent to find installations where few different kinds of circuit breakers, automatic controls, and monitoring elements, and even automatic transfer switches, will be combined in the same line-up. This recent trend in integration has started to confuse the issue as to what low-voltage switchgear really is. It needs to be remembered that switchgear is still some principal combination of metal enclosures with multi-pole circuit breakers. There are many metal-enclosed, dead front, assemblies offered that are switch and fuse combinations. Even though they look like and typically are referred to as switchgear, they are really modern versions of equipment known as switchboards. Like their forerunners, these switchboards do not address the issues with single phasing on branch feeders due to a blown fuse. Nevertheless, the incoming element may have phase loss or blown fuse detection included in it. Regarding current-carrying rating, both fuses and switches have kept pace with the developments in circuit breaker technology. Low-voltage AC

switchgear arrangements are still commonly applied to low-voltage direct current (DC) distribution centers up to 250 V. In the past, manufacturers provided two-pole, draw-out circuit breakers for DC switchgear. Today, the same three-pole design, and three-phase bus configuration, is provided for both DC and AC usages; with the extra pole either unused or installed in series with one of the others according to the particular manufacturer's application preferences. Direct-acting overcurrent trip elements are not typically offered for the new low voltage power circuit breakers. The direct-acting and electromechanical trip elements have been replaced by electronic trip elements for overcurrent protection. Nevertheless, in the insulated low voltage circuit breakers both electronic and thermal-magnetic overcurrent trip elements are provided. The electromechanical and direct-acting trip elements are still available in the secondary market as replacement for the older low voltage power circuit breakers.

Low-voltage generator paralleling switchgear continues to become more commonplace as utilities strike agreements for cogeneration contracts. Even though they are similar to unit substation type switchgear, it is vastly more advanced in the protection and control areas. It is typical today to see low-voltage switchgear with protective relaying that used to be found only on medium-voltage switchgear in a utility's generating station.

Low-Voltage Circuit Breakers

Low-voltage circuit breakers that are installed in switchgear or distribution centres are of three types:

1. Molded-case circuit breakers (MCCBs)
2. Insulated-case circuit breakers
3. Fixed or draw-out power circuit breakers.

MCCBs

Typically, MCCBs can be found in a wide range of ratings and are normally used for

low-current, low-energy power circuits. The MCCBs are equipped with self-contained overcurrent trip devices. Conventional thermal-magnetic circuit breakers use a thermal bimetallic part that has inverse time–current characteristics for overload protection and a magnetic trip part for short-circuit protection. Typical MCCBs with thermal-magnetic trip elements are dependent on the total thermal mass for their proper tripping characteristics. This implies that the adequately sized wire and lug assemblies, which correspond to the rating of the trip element, need to be used on the load terminals of such breakers. Numerous manufacturers are now switching over from bimetallic parts to power sensor (electronic) type trip elements. Magnetic-trip-only breakers do not have thermal element. These breakers are used only for short-circuit protection. Molded-case circuit breakers that have only magnetic trips are used in motor circuit protection. This configuration is desirable for smaller motors where their inrush current can ruin a delicate thermal element but where protection for winding damage is still required. The breaker provides the instantaneous (INST) protection and fault interruption, and other overload elements in the starter handle the long-time overload protection. Non-automatic circuit breakers have no overload or short-circuit protection. Typically, they are used for manual switching and isolation.

Insulated-Case Circuit Breakers

Insulated-case circuit breakers are molded-case breakers. They use glass-reinforced insulating material for greater dielectric strength. Also, they have push-to-open button, rotary-operated low-torque handles with independent spring-charged mechanism that provide quick-make, quick break protection. Different automatic trip units are available in the insulated-case breakers. Continuous current ratings reach 4,000A with interrupting capacities through 200,000A. The main differences between insulated-case breakers and heavy-duty power circuit breakers are cost, size and ease of maintenance. Insulated-case breakers are not made with easy troubleshooting or repairs as the main characteristic whereas, draw-out power circuit breakers are. To compensate for this disadvantage, many manufacturers now provide a variety of extra parts for insulated-case breakers that can duplicate the characteristics of their more expensive counterparts. Moreover, insulated-case breakers are typically suited to light industry or commercial buildings where common

or numerous operations are not expected.

Power Circuit Breakers

Heavy-duty power circuit breakers use spring-operated, stored-energy elements for quick-make, quick-break manual or electric operation. Typically, these breakers have draw-out characteristics whereby individual breakers can be put into de-energized position for testing and maintenance needs. The electrically operated breakers are actuated by a motor and cam system or a spring release solenoid for closing. Tripping action is actuated by one or more trip solenoids or flux-operated elements, typically one for the protective devices on the breaker itself, and another for externally installed controls or protective elements. The continuous frame ratings for power circuit breakers range from 400 to 4,000 A. Some manufacturers have introduced breakers with 5,000 and 6,000 A frames. Nevertheless, the long-term advantages and overall reliability of these designs have yet to be proven in real operation. Short-circuit interrupting capacities for these breakers are typically 50,000–85,000 A (RMS) for frame sizes up to 4,000 A. Bigger designs have approached 100 kA. Power circuit breakers can be extended for usages up to 200 kA interrupting when provided with assemblies or trucks made to hold Class L, current-limiting power fuses.

Fused Power Circuit Breakers

The trend toward bigger unit substation transformers and bigger connected kVA loads on such substations has provided way to power circuit breakers in tested combination with current-limiting fuses. Typically, this is done in order to increase switchgear short-circuit interrupting rating. This configuration can be used for all frame sizes. The fuses cause the same problems with single phasing as fuses in the switchboards. Nevertheless, there are various characteristics that compensate for this issue. First, most fuse assemblies are connected directly to the breakers themselves so fuses cannot be taken out or installed unless the breaker is out of service. Most manufacturers solve the single-phasing issue by either an electrical or a mechanical means of blown fuse detection, which in turn makes the breaker to trip right after the fuse has cleared. On the bigger frame sizes, where the fuses must be installed apart from the breaker cubicle, the fuse installation is on a truck or roll-out

which is mechanically interlocked with the breaker it serves. It needs to be clear that the overcurrent protection for overloads is still handled by the breaker's overcurrent trip elements, and that the fuse is not expected to clear except for the highest short circuits.

Overcurrent Protective Elements

The low-voltage overcurrent protective elements are direct-acting (electromechanical) trip (series trip) and static (electronic) trip. These overcurrent protective elements are used in the power circuit breakers as mentioned above.

Direct-Acting Trip

The direct acting overcurrent trip element is commonly known as series trip, electromechanical and dashpot trip element. This element uses the force made by the short-circuit current passing through it to trip its circuit breaker by direct mechanical action. These elements are operated by (1) an electromagnetic force made by the short-circuit current passing through the trip element coil (the trip coil is typically connected in series with the electrical circuit or in some situations to the secondary of current transformers) or (2) a bimetallic strip actuated by the heat created by the fault current. Typically, the bimetallic strip is connected in series with the circuit. Typically, a combination of thermal (bimetallic strip or equivalent) and INST magnetic trip is used on molded-case breakers to give time delay operation for moderate over-currents (overloads) and INST operation for high- magnitude of short-circuit current. Typically, the thermal trip is nonadjustable in the field or there is some equipment that has limited range of adjustment, such as 0.8 to 1.25, whereas the instantaneous (INST) trip is available as adjustable or nonadjustable. The adjustable-trip range differs from low to high with several intermediate steps. The number of available steps may differ for different configurations and sizes.

Direct-acting trips on insulated-case and heavy-duty power circuit breakers are electromagnetic. Three trip elements are available as: (1) long time delay (LTD), (2) short time delay (STD), and (3) INST. Combinations of these are available to provide protection for over-currents. A trip element is installed in each phase of the electrical circuit. The LTD, STD, and INST trip elements are available in minimum,

intermediate, and maximum time bands to allow the coordination of different trip devices in series. All these elements have adjustable settings. The time delay bands are accomplished by the action of the solenoid's pull against springs, pneumatic, or hydraulic elements. Since these devices are completely mechanical, different characteristics cannot be provided in a single trip element. Even though some calibration points and some effects on the time can be changed by adjustments, totally different delay bands can be selected only by physically changing out the trip elements with others of the desired type.

Direct-acting trips are still used for some installations, and are still needed on power circuit breakers used on DC unit substations.

Static- and Electronic-Trip Elements

Static-trip elements are totally static. They have no moving parts. These elements use semiconductor-integrated circuits, capacitors, transformers, and other electric parts. Static-trip elements work to open the circuit breaker when the current–time relationship surpasses a predetermined value. The energy needed to trip the breaker is obtained from the protected circuit. No external power, such as DC batteries, is needed. The complete static-trip mechanism consists of:

1. Primary circuit current transformers
2. Static logic box
3. Tripping actuator (a magnetically held latch element).

The current transformer sensors are of toroidal type. One per phase is installed on the circuit breaker primary studs. These transformers give a signal to the static-trip element proportional to the primary current.

The static logic box gets the signal from the primary current transformer. It checks the signal, discovers overloads or faults, and executes the required operation in line with predetermined settings. The tripping actuator gets the output signal from the static logic box and in turn causes the circuit breaker contacts to open.

Manufacturers have put considerable effort in the development and application of solid-state trip elements over the past few decades. The motivation for this effort has been to bring protective elements to market that provide improved characteristics over the original direct-acting designs yet preserve the totally self-contained concept exhibited by their forerunners. When the static trips were first introduced, manufacturers had problems to give reliable and repeatable elements that would prove to be lower maintenance items than the ones they replaced. These issues were not easy to resolve. The main issue has always been related to a consistent and accurate method to both derive operational power from the signals resulting from current passing through the breaker, and to precisely measure the current at the same time. The developments came one by one. For some time, many manufacturers still had to rely on a magnetic element to provide an INST function. The configurations of that time did not allow an electronic element to build up adequate power to trip the actuator sufficiently fast to be called INST.

Certain configurations have used (and may still use) two sets of current sensors, or one set of sensors with dual secondary windings, in order to derive a signal to monitor and another to serve as the power supply. Extra sensors may be needed for a function that direct-acting trips could not provide— earth fault. Three-phase, three-wire and three-phase, four-wire earth fault detection systems are provided. The signals from either the three or four sensors are processed to discover if all INST currents add up to zero. Hence, it should be clear that if earthing conductors are used, they should not be included along with any neutral connections. When current returns to its source via an earth conductor, the monitored currents no longer add up to zero and the trip element operates. The connections and current sensors used for a three-phase, four-wire, plus earth conductor on a feeder breaker are presented in Figure 1. Developments and enhancements are continuously being made on static and electronic- trip elements. For instance, the older type static- and electronic-trip devices measured peak and/or average currents and then scaled these currents to RMS values based on the characteristics of pure sine wave. Hence, the older static- and electronic-trip devices along with the electromechanical analog type trip devices are susceptible to tripping issues due to harmonic currents made by nonlinear loads. The nonlinear loads are variable speed drives, switch-mode power supplies, electronic ballasts, etc. The current electronic devices are completely

microprocessor based and are programmed to sample the current waveform at predetermined intervals to derive the effective RMS value of the load currents. Microprocessor trip devices with RMS sensing avoid false tripping issues due to harmonic current peaks and discover the true heating current in the circuit. Also, microprocessor trip devices offer the capability for voltage, currents, kilowatts, kilowatt demands, kilowatt hours, kilovars, power factor and frequency digital readouts. These readouts can be local or can be transferred to a remote location via digital communication network. Certain microprocessor protection packages offer extra protection characteristics that were originally available only by means of installing extra protective relays.

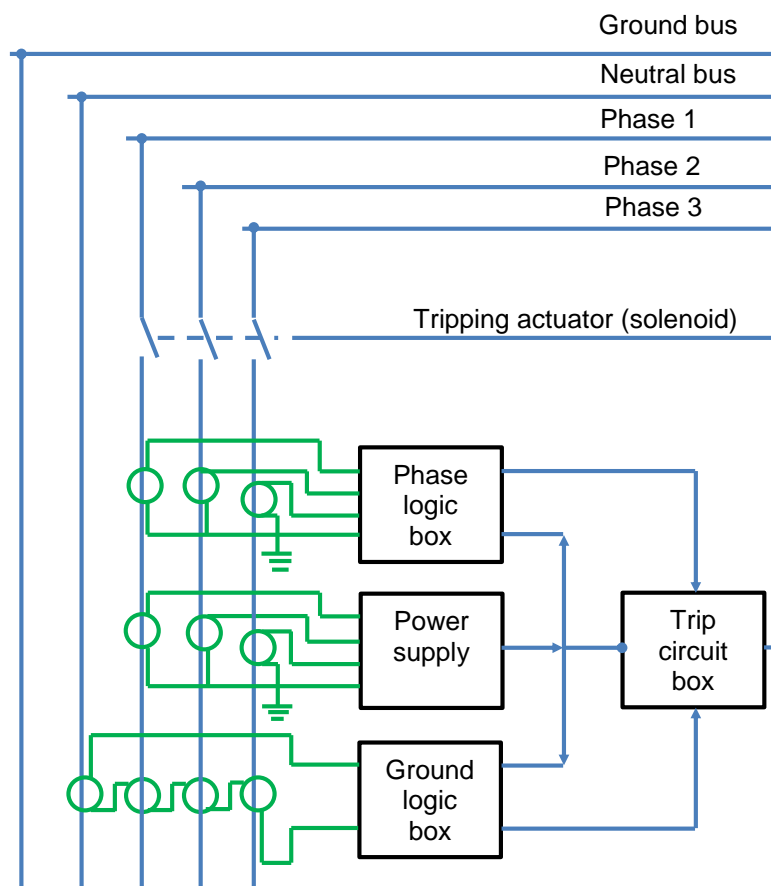

Figure 1. Functional scheme of static-trip element

Also, the current microprocessor trip devices have lower energy demands for static-trip logic. Typically, most configurations now use less and smaller current sensors than would have been supplied for the breaker whose arrangement is presented in Figure 1. Not only this equipment offers all of the characteristics mentioned above

but also it can measure the true RMS current. This allows breaker to be immune to false tripping due to current waveforms with high distortion or harmonic content.

Three current sensors are installed on the breaker and give the self-powered input to the protection engineer. Where four-wire earth fault is specified, a fourth current sensor is installed near the neutral bar in the cable compartment. Sensors are made of molded epoxy for extra protection against damage and moisture. Additional current sensors with four taps are available to increase the flexibility and range of the whole configuration. In the current designs rating plug is provided for a given sensor and breaker to make the continuous breaker rating. A flux-shift element is automatically powered and controlled by the protection programmer and causes the breaker to trip on signal. This low-energy positive action tripping element is placed near the trip bar on the breaker. This element automatically resets when the moving contacts on the breaker have completely opened.

Programmable microelectronic processor that forms the basis of the flexible, precise protection system offers:

- Time-current features
- Three local and remote mechanical fault sensors
- Local and remote long-time pickup LED zone indicator
- Selective interlocking
- Integral earth-fault trip

All adjustable programmer functions are automatic and self-contained and do not need external relaying or power supply.

Monitoring and Protection Packages

A natural outgrowth of the move to static-trip elements has been to provide elements that can display the quantities they are monitoring. This trend has come in response to user's concerns regarding the convenience in monitoring loads and in

troubleshooting a given distribution network. Typically, low-voltage switchgear has space limitations within its breaker cubicles. Consequently mounting space for extra current transformers is limited. Manufacturers are starting to provide monitoring packages that use benefits of the signals already made available by the protection equipment. The information can be displayed on the trip element or sent to a cubicle door mounted display. Automated data processing centres and cogeneration sites have set up complex monitoring systems by using the benefits of the communications functions that are now provided. Almost every feeder at a user's site can be monitored and all of its electrical performance data sent back to a central system. The trend in interfacing with communications to field programming units (FPUs); remote terminal units (RTUs), programmable controllers (PLCs) used as sequence controllers, data collectors and sequence control and data acquisition (SCADA) systems is expected to continue. Many of the devices used in these systems are mounted directly in the switchgear.

Fuses

Two basic families of fuses are current limiting and noncurrent limiting. The current-limiting fuse melts and extinguishes the arc in a half-cycle or less. The noncurrent-limiting fuse may melt in less than a half-cycle when exposed to very high short-circuit current values, but is unable to extinguish the arc in a half-cycle. Since the arc is a flexible conductor, the noncurrent-limiting-type fuse will allow the short-circuit current to reach its maximum peak value. The current-limiting type of fuses are provided with mechanisms to extinguish the arc, thereby stopping the short-circuit current from reaching its maximum peak value. The fuses are used in combination with circuit breakers, motor starters, disconnect switches to secure protection similar to the circuit breaker overcurrent trip elements. Nevertheless, fuses have fixed time–current relationships and hence do not give the same flexibility as the overcurrent relationships. Hence, they do not give the same flexibility as the overcurrent trip elements. Fuses cannot open and close a circuit by themselves. Fuses must be combined with some additional element, such as a disconnect switch, a circuit breaker, or a contactor. Fuses can be divided into medium- and low-voltage fuses.

Low-Voltage Fuses

Low-voltage fuses are can be grouped as follows:

1. Cartridge fuses that are made for the circuit protection
2. Plug fuses that are made for the circuit protection
3. Supplementary fuses that are made for the protection of small equipment etc.
4. Special fuses that are made for the protection of electrical elements such as capacitors, welders, and rectifiers

Relevant standards to these fuses are NEMA FU-1 dated 2002, and ANSI/UL 248-1 through 248-15 dated 2000. ANSI/UL 248-8 covers the class J fuses and ANSI/UL 248-10 covers class L fuses. Moreover, UL has classified fuses as current limiting and noncurrent limiting, as presented in Table 1. Also, classes R, J, L, T, and CC fuses are made as branch circuit fuses appropriate for protection of distribution systems and wiring.

Table 1. Current and Noncurrent-limiting fuses

Noncurrent limiting	
Plug fuses (C and S) Voltage rating, 125V AC Current rating, 0-30A Interrupting rating, not more than 10,000 A	Class H Voltage rating, 250 and 600 V AC Current rating, 0-600A Interrupting rating not more than 10,000 A
Current limiting	
Class J Voltage rating, 600V AC Current rating, 0-600A Interrupting rating, 200,000 A sym	Class L Voltage rating, 600V AC Current rating, 601-6000A Interrupting rating 200,000 A sym
Class K Voltage rating, 250-600V AC Current rating, 0-600A Interrupting rating 50,000-200,000 A sym	Class R Voltage rating, 250 and 600V AC Current rating, 0-600A Interrupting rating 200,000 A sym
Class T Voltage rating, 300 and 600V AC Current rating, 0-600A Interrupting rating, 200,000 A sym	Class G Voltage rating, 300V AC Current rating, 0-60A Interrupting rating, 200,000 A sym
Class RK1	Class RK5

Voltage rating, 250-600V AC Current rating, 0-600A Interrupting rating, 200,000 A sym	Voltage rating, 250-600V AC Current rating, 0-600A Interrupting rating, 200,000 A sym
Class CC Voltage rating, 600V AC Current rating, 0-30A Interrupting rating, 200,000 A sym	Class C Voltage rating, 600V AC Current rating, 0-1200A Interrupting rating, 200,000 A sym
Class CA/CB Voltage rating, 300 or 600V AC Current rating, CA: 0-30A, CB:0-60A Interrupting rating, 200,000 A sym	

Since fuses are single-phase interrupters, they offer good protection for single-phase circuits. Nevertheless, for multiphase systems, single-phase interrupters can create issues such as single phasing, back feeding, and ferroresonance. Single phasing can be damaging to motors owing to the flow of negative-sequence currents, which can create increased motor heating, causing motor damage or reducing its expected life. The degree of motor life reduction is a function of motor temperature and elapsed time between single-phase occurrence and motor de-energization.

The term back feeding is used to describe the situation when fault current continues to flow from the remaining energized phases, most probably at a decreased value owing to the extra impedance that has been inserted in the current path. The level of fault current reduction will impact the fuse time response in the remaining phases. As fuse interrupting time grows, the degree of damage also increases. Today's switchgear configurations using fuses as overcurrent protective elements use anti-single phase protection characteristics. The anti-single phase characteristic in the fused switchgear open all three lines due to a single fuse blowing, therefore averting previously discussed adverse effects.

Disconnect Switches

Disconnect switches are typically installed in low- and medium-voltage systems. Disconnect switches can be divided into low-voltage (600 V and below) and medium-voltage (601 V through 15 kV) groups.

Low-Voltage Disconnect Switches

Low-voltage switches can be organised into three broad groups:

1. Isolating switches

2. Safety switches

3. Interrupter switches

The isolating switch does not have interrupting or load-carrying capability. It only provides isolation of the circuit or load by manual means after the power flow is stopped by the circuit protective equipment. The safety switch is a load-break switch having a quick-make and quick-break contact mechanism. Safety switches are installed in small power systems with limited short-circuit capacity. The safety switch can be fused or unfused. The interrupter switch is of quick-make, quick-break type and can interrupt at least 12 times its continuous current rating. They are assigned horsepower rating. These switches can be found in continuous rating from 30 to 1200 A and can part of switchboards, panel boards, and grouped motor control centres. The interrupter switch can be used with or without fuses depending upon the specific installation.

Certain industrial systems or commercial buildings will use switchgear or switchboards with a high pressure or bolted pressure, three-pole switch working as incoming service main disconnects. The main characteristic of these switches is their continuous current ratings of up to 3000 or 4000 A. At these currents, very high contact pressure is needed on the conducting surfaces in order to keep temperature rises to reasonable levels. The switches themselves carry an interrupting rating that is similar to those for three-pole interrupter switches but not as high as that for power circuit breakers. Interrupting capacity for short circuits is almost always handled by current-limiting fuses, which are an integral part of the switch. Majority of manufacturers offer single phase, blown fuse, and earth fault accessories so that the switches can be installed on low-voltage service entrances. Unlike trip elements applied to circuit breakers, this protective equipment is not self-powered. Instead, they take operating voltage from a small control power transformer on the source side of the switch. Typically, the mechanical design of these switches is based on a minimum of operations. It is anticipated that the number of operations is less than for insulated-case breakers. It is typically limited to isolation during maintenance or for

severe earth faults not successfully cleared by other methods.

Selection and Application of Low-Voltage Devices

The modern distribution systems have high short circuit current. Hence, this demands special consideration so that equipment may be applied within its rating. Moreover, the switchgear needs to be protected against all types of faults, from low-level arcing faults to bolted faults. The protection arrangement needs to be selective, meaning that the fault at a remote area in the system needs be localized without unnecessary tripping of either the main breaker system or any intermediate breakers. The distribution system needs to be planned to offer continuity and service reliability. This can be accomplished by using two or more separate distribution systems instead of one big system. The continuous current rating of the main protective equipment needs to be adequate for the served load. Protective equipment should not be paralleled to achieve higher rating. As a general rule, the bus bars are rated on the basis of not more than 800 A/in² of aluminium or 1000 A/in.² of copper. The operation of protective equipment is based upon an ambient temperature of 40 °C, and if this equipment is to be applied at higher temperature, the manufacturer needs to be consulted. The bus short-circuit rating is limited to the interrupting rating of the lowest rated protective element, and the available short-circuit current should not surpass this figure.

The application of circuit breakers and fuses has to be considered to determine which offers the most adequate protection. Attention needs to be given to anti-single-phase elements when three-pole interrupter switches with fuses are used, because fuses are single-pole interrupter switches. An arcing fault may not be cleared by a single-pole interruption. It can be back fed from the other live phases. Due to this, serious equipment burn downs may happen. Ferroresonance is the result of interaction between the reactance of a saturable magnetic equipment, such as a transformer, and system capacitance. Ferroresonance can also happen due to a single phasing condition. This condition mainly happens in high- and medium-voltage electrical systems and results in a very high voltage on the order of three to five normal system voltage which is imposed on the involved circuit, causing equipment damage. It is important to remember that fuses need to be used in systems where

the system voltage is compatible with the fuse voltage rating. The reason for this is that the arc voltage created by a fuse when interrupting is few times its voltage rating and, if misapplied, could subject the system to overvoltage conditions, creating equipment damage.

The current-limiting characteristics of current-limiting fuses are definite strong pluses for many installations. Nevertheless, they do not limit current for all values of fault current. In the case fault current magnitude is equal to or higher than the fuse threshold current, they will always be current limiting. Nevertheless, if the fault current magnitude is lower than the fuse threshold current, but higher than the current magnitude indicated at the intersection of the maximum peak current curve and fuse curve, the fuse may or may not be current limiting. For fault current magnitude shown by the above curve intersection, the fuse is never current limiting.

For this reason and arc-voltage considerations, when using current limiting fuses to increase the interrupting rating of other protectors, the fusing suggestions of the product manufacturers, not the fuse manufacturer, need to be listened. Fused devices can be opened and closed manually or electrically to provide circuit protection. Nevertheless, the fuse and equipment needs to be coordinated and tested as a combination. The fuse's adequate operation as a circuit protector and switching element needs to be certified by one manufacturer.

When fused switches are electrically controlled, attention is needed not to let the switch open due to fault conditions. The fault current, if not sufficient to cause interruption before the switch contacts or blades open, could be higher than the contacts' or blades' interrupting capability. This would result in a hazardous situation. Generally, fused switches require the same application considerations as previously mentioned.

Fused motor starters used in medium and low-voltage electrical systems avoid the ferroresonance issue owing to their location in the system. Auxiliary equipment can be supplied with motor starters to offer a complete overload protection and anti-single-phasing protection. The selection and application of switchgear needs to be approached on an engineering basis. To give reliability, ease of maintenance, and

operation continuity, adequately rated equipment and adequate circuit protection are needed throughout the entire system, from the place where the power system enters the facility down to the smallest load.

Evaluating Service Life of Low-Voltage Breakers

NEMA, ANSI and IEEE standards for low-voltage power circuit breakers and MCCBs discuss performance criteria for evaluating the service life of manufactured products. The industry standards for low-voltage breakers are ANSI/ IEEE C37.16-2000, C37.26-2003, C37.50-2000, C37.51-2003, NEMA AB-1-2002, and AB-4-2003. Also, the MCCBs are tested at the manufacturer's production facility and/or at UL facilities in line with standards published by the industry and UL-489-2002. The performance criteria included in industry standards can also help users anticipate the need for maintenance testing, inspections, refurbishment, and/or replacement of the manufactured equipment. This paragraph gives an overview of the requirements included in the referenced industry standards and the methods commonly used by manufacturers in equipment production. It is anticipated that an understanding of the endurance requirements detailed in the standards should give insights that can be used to inspect and assess the health for continued reliable operation of low-voltage power circuit breakers and MCCBs. There are four essential electrical ratings and endurance requirements for switchgear devices and assemblies such as circuit breakers.

Maximum Voltage Rating or Nominal Voltage Class

Low-voltage power circuit breakers are labelled with the maximum system voltage at which they can be used. Standard maximum voltage ratings are 635, 508, and 254 V for application of the breakers in 575, 480, and 208 V electrical systems, respectively. A low-voltage breaker can be installed in a circuit that has a nominal voltage rating less than the breaker's maximum voltage rating. For instance, a 635 V rated circuit breaker can be applied in a 208, 240, 480, or 600 V rated circuit. For fused breakers, the 635 V maximum voltage rating becomes 600 V to match the fuse voltage rating.

Continuous Current Rating

The continuous current rating of an isolator switch, circuit breaker, load-break switch, motor control centre or switchgear assembly is the number of amperes that the device can continuously transfer without the temperature of any insulation element becoming higher than its nominal temperature. For low-voltage power circuit breakers and MCCBs, the continuous current rating of the breaker's frame is known as the frame size. For any low-voltage power circuit breaker that can accept a replaceable trip element, installation of a trip element that has a continuous current rating that is less than the frame size decreases the continuous rating of the circuit breaker. It is not allowable to install a trip element that has a continuous current rating that is higher than the breaker's frame size.

Rated Short-Circuit Current (Circuit Breakers)

Low-voltage circuit breakers are made with one or more interrupting ratings (rated short-circuit current), usually known as the interrupting ampere capability (AIC). These interrupting ratings are the maximum values of available (prospective) short-circuit current (fault) that the breaker is able to break (short-circuit duty cycle) at different maximum voltage values. Available current is determined by the industry standards as the anticipated RMS symmetrical value of current at a time one half-cycle after short-circuit initiation. The maximum fault in electrical system happens at one half-cycle time. The low-voltage breakers are fast operating and start to part contacts at about one half-cycle time which is point of maximum short-circuit current. Hence, as the breaker contacts start to part, i.e., as the breaker starts to interrupt the short-circuit current it is exposed to the maximum asymmetrical current. The asymmetry of the short-circuit current is a function of the X/R ratio, or the power factor of the short-circuit current. The ANSI/UL standard 489 details the criteria for conducting interrupting ability tests for molded-case breakers. These standards specify the power factor of the test circuit with the needed current flowing that is to be used for establishing the asymmetry of the short-circuit current. The NEMA AB-1-2002 and UL 489-2002 standards have determined three asymmetry groups (i.e., power factor) of short-circuit current interrupting capabilities. The three asymmetry groups (short-circuit current and power factor) presented in NEMA AB-1 and UL 489 are presented in first two columns of Table 2.

Table 2. Test circuits power factor – NEMA-AB-1-2002 and UL-489-2002

Test Circuit (A)	Power Factor	X/R	Multiplying Factors	
			M _A	M _M
Nema-AB-1-2002				
10,000 or less	0.5	1.732	1.026	1.013
10,001-20,000	0.3	3.15	1.130	1.064
Over 20,000	0.2	4.87	1.247	1.127
UL-489-2002				
10,000 or less	0.45-0.5	1.98-1.732	1.041-1.026	1.021-1.013
10,001-20,000	0.25-0.3	3.87-3.15	1.181-1.13	1.092-1.064
Over 20,000	0.15-0.2	6.6-4.87	1.331-1.247	1.172-1.127

The X/R ratio and the related multiplying factors are presented in columns 3 and 4 of Table 2. What the UL 489 and industry standards are mentioning is that the asymmetry is higher for fault currents at the locations where the short-circuit current is high, and it is smaller at locations where the short-circuit current is less. Another way of expressing this criterion is to mention that the breakers installed closer to the substations will experience bigger short-circuit currents with bigger asymmetry in the fault current, thereby exposing a breaker to undergo a higher short-circuit duty while breaking the fault. The opposite is correct for breakers installed further away (downstream) from the substation since such breakers will experience lower short-circuit currents and lower asymmetry in the short-circuit current.

This all means that power factor is lower (or X/R ratio is higher) near the substations and power factor is higher (or X/R ratio is lower) further away from the substation. It has to be clear that the maximum asymmetry for the low-voltage circuit breakers is capped at power factor of 0.15, X/R ratio of 6.6. Nevertheless, examination of the manufacturer and UL data indicates that majority of breakers are tested at a maximum power factor of 0.20 or X/R ratio of 4.87. The low-voltage breaker's short-circuit interrupting capacity is indicated in symmetrical amperes since the asymmetry is already included in the test circuit current when the breakers are tested for interrupting capacity. Also, it has to be kept in mind that the short circuit duty cycle is a specific test that is done on a prototype model of a circuit breaker. Complete explanation of this test can be found in ANSI/IEEE standards C37.16, C37.50, UL 489, and NEMA AB-1.

Table 3 presents the interrupting symmetrical ampere capabilities included in NEMA AB-1 for the breakers produced by NEMA member companies.

Table 3. Preferred short circuit rating in RMS symmetrical amperes

7,500	20,000	35,000	85,000	200,000
10,000	22,000	42,000	100,000	
14,000	25,000	50,000	125,000	
18,000	30,000	65,000	150,000	

Each circuit breaker model can have a different set of interrupting current capacities that are presented in Table 3. The low-voltage breaker interrupting capacity changes with the applied voltage. For instance, a 1600 A-rated breaker applied at 240 V might have an interrupting capacity of 65 kA at 240 V, whereas the same breaker applied at 480 V would have an interrupting capacity of 50 kA. The interrupting capacity also varies if the breaker's automatic trip element has a short-time trip function rather than an INST trip function. For instance, a 4000 A-rated circuit breaker that has an INST trip might have an interrupting capacity of 150 kA at 240 V, whereas the same breaker provided with a short-time trip has an interrupting capability of 85 kA at 240 V. Low-voltage power circuit breaker that is provided with current limiting fuses (current limiters) has short-circuit current rating equal to 200 kA. Rated short-circuit current is affected by the circuit breaker ability to close and latch against, carry, and subsequently interrupt, a fault current. Breakers have closing and latching capacities, usually known as momentary rating, relate to the breaker's ability to sustain the mechanical and thermal stress of the fault current first half-cycle, i.e., asymmetrical short-circuit current. Low-voltage power circuit breakers and MCCBs display do not have nameplate information concerning momentary rating. These breaker types are commonly tested and used according to their interrupting current capacity in RMS amperes. The reason that momentary ratings do not appear on their nameplates is that these breakers are examined with the asymmetry already included in the symmetrical amperes of the test circuit. For specific system applications that have bigger asymmetrical value than the asymmetry of test circuit current (i.e., $X/R = 6.6$), a circuit breaker of bigger interrupting current rating needs to be used.

Short-Circuit Current Ratings

A panel board has short circuit current rating shown on its nameplate. A panel board cannot be used in any circuit whose available fault current is bigger than its short-circuit current rating. The panel board short circuit current rating is limited to the lowest value of rated short-circuit current for any circuit breaker that is installed within the panel board. The motor control centre short circuit withstand rating is the average RMS current that its busses can carry for 2 s. A motor control centre cannot be used in any circuit whose available fault current is higher than its short-circuit withstand rating. The metal-enclosed or metal-clad switchgear rated momentary current represents the maximum RMS current that it is required to sustain during a test of 10 cycles duration. This test is completed on a prototype model. The nominal short time current of metal-enclosed or metal-clad switchgear is the average RMS current that it can sustain for a period of 2 s.

Endurance Demands for Low-Voltage Breakers

The ANSI/IEEE standard for switchgear C37.16-2000 includes endurance demands of low-voltage power circuit breakers and AC power circuit protectors. Even though mainly used by manufacturers who have an interest in assuring durable equipment, these endurance demands can also help equipment users to plan the need for maintenance or replacement. In order to check that a particular circuit breaker design meets the endurance demands, a manufacturer completes all endurance tests on a single circuit breaker. Table 4 represents the number of times that the circuit breaker is needed to make and subsequently break line currents that are 600% of the breaker's rated continuous current. The test technique includes specifications for how much time can elapse between two switching actions. The breaker elements that are most likely to become worn during this endurance check are arcing tip and arc chutes.

Table 5 represents the number of open–close or close–open operations that the breaker's operating mechanism is needed to sustain when making and breaking 100% of its rated current (electrical endurance) and no current (mechanical endurance). The elements that are most likely to become worn during this endurance check are latches, cam, rollers, bearings and pins. In order to successfully complete

this check, adjusting, cleaning, lubricating, and tightening are allowed at the intervals presented in column 2 of Table 5. The numbers in this column suggest that maintenance is needed in order to allow a circuit breaker's operating mechanism to achieve its full lifetime. Issues strongly related to breaker maintenance include

1. The circuit breaker needs to be in a condition to transfer its rated continuous current at maximum rated voltage and complete at least one opening operation at rated short-circuit current. After completion of this series of operations, functional part replacement and general maintenance may be required.
2. If a fault operation happens before the completion of the listed operations, servicing may be required, depending on previous accumulated duty, fault amplitude, and expected future service.
3. Maintenance consists of adjusting, cleaning, lubricating, tightening, and the like, as suggested by the manufacturer. When current is broke, dressing of contacts may be also needed.

Table 4. Overload switching demands for low voltage AC circuit breakers

Line No.	Frame Size Amperes	Number of Make-Break Actions
1	225	50
2	600	50
3	800	50
4	1600	38
5	2000	38
6	3000	-
7	3200	-

Breaker operations listed for endurance are based on servicing at intervals of 6 months or less. The implication for maintenance is that a power circuit breaker might not be suitable for continued operation after it has interrupted a fault current at or near its short-circuit current rating. Unless the amplitude of a fault current is known to have been significantly lower than rated short circuit value, it is recommended practice to complete a physical inspection on a breaker before it is used to reenergize a power circuit. Physical checks at periodic maintenance intervals will reveal wear of elements and parts before a circuit breaker loses its capability to break an overload current or a fault. For circuit breakers that are provided with

monitoring functions the number of overload operations can be automatically recorded that can further be evaluated to check if a circuit breaker is in need of an inspection.

Table 5. Endurance demands for low-voltage AC power circuit breakers

Circuit breaker frame size (A)	Number of make-break or close-open Actions			
	Between Servicing	Electrical Endurance	Mechanical Endurance	Total No. of actions
600	1750	2800	9700	12500
800	1750	2800	9700	12500
1600	500	800	3200	4000
2000	500	800	3200	4000
3000	250	400	1100	1500
3200	250	400	1100	1500
4000	250	400	1100	1500

The demands for completing endurance tests for MCCBs are presented in NEMA AB-1 and UL-489 and the criteria differ from the ANSI C37.16 recommendations. The electrical operation categories are referred to as operation with current and the mechanical tests are referred to as operation without current. The demands for the endurance verifications for MCCB are presented in Table 6.

Table 6. Endurance Demands for MCCBs

MCCB Frame Size (A)	Number of Make-Break or Close-Open Actions			
	No. of Operations/ Minute	With Current	Without Current	Total
100	6	6,000	4,000	10,000
150	5	4,000	4,000	8,000
225	5	4,000	4,000	8,000
600	1	500	3,000	3,500
1,200	1	500	2,000	2,500
2,500	1	500	2,000	2,500
6,000	1	400	1,100	1,500