Generator Protection

Course No: E04-047

Credit: 4 PDH

Velimir Lackovic, Char. Eng.



Continuing Education and Development, Inc.
22 Stonewall Court
Woodcliff Lake, NJ 07677

P: (877) 322-5800
info@cedengineering.com

GENERATOR PROTECTION

Introduction

This course covers generator protection concepts and theory. Protective devices that are described in this course can be used in multiple generator protection configurations. There are various protection relays and those are used for protection against a wide variety of conditions. Protection relays protect the generator, prime mover, external power system or the processes it supplies. The fundamental principles that are covered in this course are equally applicable to individual relays and to multifunction numeric relays. The protection engineer has to balance the expense of using a particular protection relay against the consequences of losing a generator. The total loss of a generator may not that bad especially in situations when it represents a small portion of the investment in an installation. However, the effect on service reliability and upset to loads has to be considered. Damage and product loss in continuous processes can represent the major concern rather than the generator unit. Hence, there is no universal protection solution based on the MW rating. However, it is expected that a 500kW, 480V, standby reciprocating engine will have less protection elements and simpler protection arrangement than a 400MW base load steam turbine unit. One typical dividing point is that the extra CTs required for current differential protection are less commonly encountered on generators less than 2MVA, generators rated less than 600V, and generators that never work in parallel with other generation.

This course explains protection relay selection process by detailing how to protect against each fault type or abnormal condition. Also, recommendations are made for what is considered to be minimum protection as a baseline. After making the baseline, extra protection relays, may be introduced. The topics included in this course are as follows:

- Earth Fault (50/51-G/N, 27/59, 59N, 27-3N, 87N)
- Phase Fault (51, 51V, 87G)
- Backup Remote Fault Detection (51V, 21)
- Reverse Power (32)

- Loss of Field (40)
- Thermal (49)
- Fuse Loss (60)
- Overexcitation and Over/Undervoltage (24, 27/59)
- Inadvertent Energization (50IE, 67)
- Negative Sequence (46, 47)
- Off-Frequency Operation (81O/U)
- Sync Check (25) and Auto Synchronizing (25A)
- Out of Step (78)
- Selective and Sequential Tripping

Ground Fault Protection

The following cases describe three grounding impedance levels: low, medium, and high.

A low impedance grounded generator relates to a generator that has zero or minimal impedance at the Wye neutral point. In that case during an earth fault at the generator HV terminals, earth current from the generator is roughly equal to 3 phase fault current.

A medium impedance grounded generator relates to a generator that has substantial impedance at the Wye neutral point. In that case during an earth fault, a decreased but detectable level of earth current, commonly in the 100-500A range, flows.

A high impedance earthed generator refers to a generator with big earthing impedance. In that case during an earth fault, a nearly undetectable level of fault current flows, requiring earth fault monitoring with voltage based (for example, 3rd harmonic voltage monitoring and fundamental frequency neutral voltage shift monitoring) protection relays. The location of the earthing, generator neutral(s) or transformer also affects the protection scheme.

The position of an earth fault within the generator winding, as well as the grounding impedance, affects the level of short circuit current. Assuming that the generated voltage along each winding portion is uniform, the pre-fault line-ground voltage level

is proportional to the percent of winding between the fault location and the generator neutral as shown in V_{FG} in Figure 1. Assuming an impedance earthed generator where $(Z_{0,SOURCE} \text{ and } Z_N) \gg Z_{WINDING}$, the current level is directly proportional to the distance of the point from the generator neutral (please refer to Figure 1(a)), so a short circuit 10% from neutral creates 10% of the current that flows for a fault on the generator terminals. While the current level decreases to zero as the neutral is getting closer, the insulation stress also decreases, tending to decrease the chance of a fault near the neutral. If a generator earthing impedance is low relative to the generator winding impedance or the system earthing impedance is low, the fault current decay will be non-linear. For I_1 in Figure 1, lower fault voltage is offset by lower generator winding resistance. Typical example is presented in Figure 1(b). The generator differential relay (87G) should be sufficiently sensitive to sense winding earth faults with low-impedance grounding as shown in Figure 2. In this situation a solid generator-terminal fault creates roughly 100% of rated current. The differential relay minimum pickup setting need to be adjusted to detect faults on as much of the winding as possible. Nevertheless, settings below 10% of full load current introduce increased risk of mal-operation due to transient CT saturation during external faults or during step-up transformer energization. Lower pickup settings are advised only with high-quality CTs and a good CT match (for example, same accuracy class and same burden).

In the case, 87G relaying is installed as shown in Figure 2, relay 51N backs up the 87G, as well as external relays. In the case, 87G is not installed or is not sufficiently sensitive for earth faults, than the 51N gives the primary generator protection. The benefit of the 87G is that it does not require to be delayed to coordinate with external protection. Nevertheless, delay is needed for the 51N. Engineers needs to be aware of the effects of transient DC offset induced saturation on CTs during transformer or load energization with respect to the high speed operation of 87G protection relays.

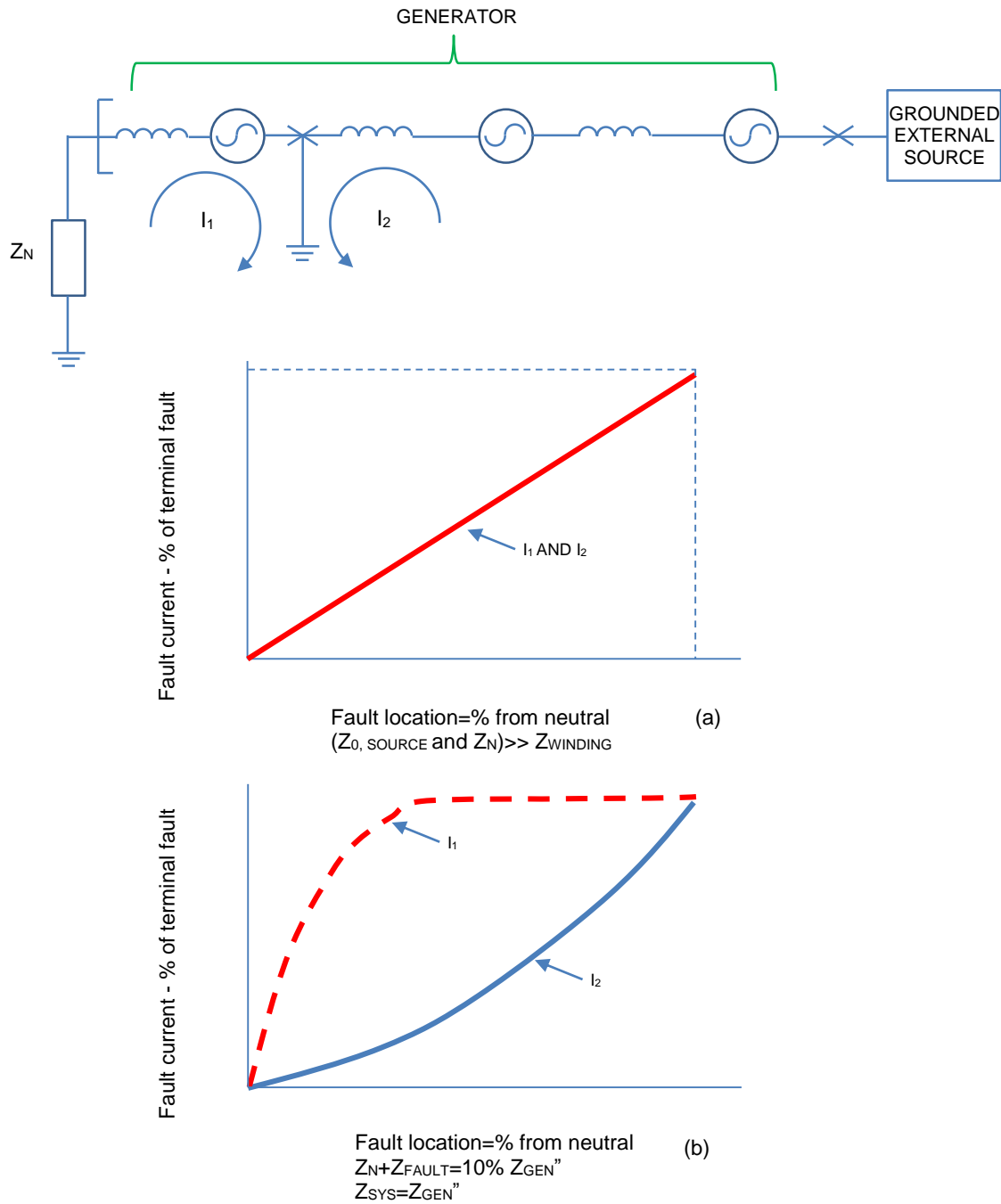

Figure 1. Effects of fault position within generator on current level

Transient DC offset may create CT saturation for many cycles (most probably not more than 10), which may start 87G relay false operation. This may be addressed by not block loading the generator, avoiding large transformers sudden energization, installing overrated CTs, putting insignificant time delay to the 87G trip circuit, or insensitively setting the protection relay.

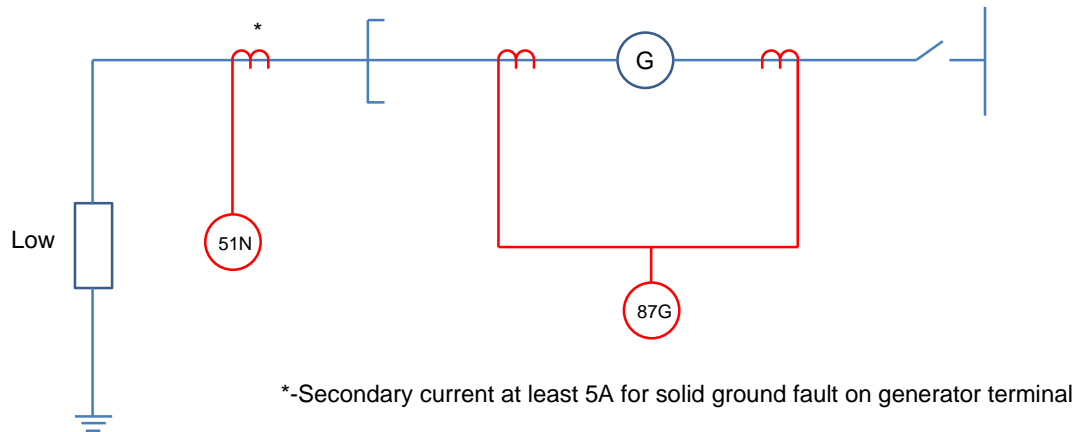

Figure 2. Earth fault relaying generator low-impedance earthing

The neutral CT has to be chosen to create a secondary current of at least 5A for a solid generator terminal fault, giving sufficient current for a fault near the generator neutral. For instance, if a terminal fault creates 1000A in the generator neutral, the neutral CT ratio must not exceed 1000/5. For a fault 10% from the neutral and assuming I_1 is proportional to percent winding from the neutral, the 51N current will be 0.5A, with a 1000/5 CT.

Figure 3 presents multiple generators with the transformer that provides the system earthing. This scheme is applicable if the generators will not be operated with the transformer out of service. The arrangement will lack earth fault protection before generator breakers are closed. The transformer could serve as a step-up as well as an earthing transformer. An overcurrent relay 51N or a differential relay 87G gives the protection for each generator. The transformer needs to generate a ground current of at least 50% of generator rated current to provide about 95% or more winding coverage.

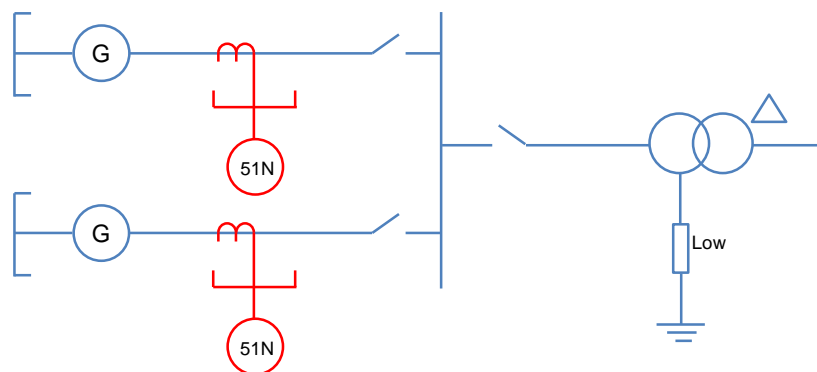

Figure 3. Externally earthed system with multiple generators

Figure 4 presents a unit-connected scheme (generator and step-up transformer directly connected with no low-side breaker), using high resistance earthing. The earthing resistor and voltage relays are connected to the distribution transformer secondary. Typically, the resistance is chosen so that the reflected primary resistance is roughly equal to one-third of the single phase line-ground capacitive reactance of the generator, bus, and step-up transformer. This will limit fault current to 5-10A primary.

Adequate resistor damping stops ratcheting up of the sound-phase voltages in the presence of an intermittent ground. The low current level decreases the chance of sufficient iron damage to require re-stacking. Due to the low current level, the 87G relay will not trip for single phase earth faults.

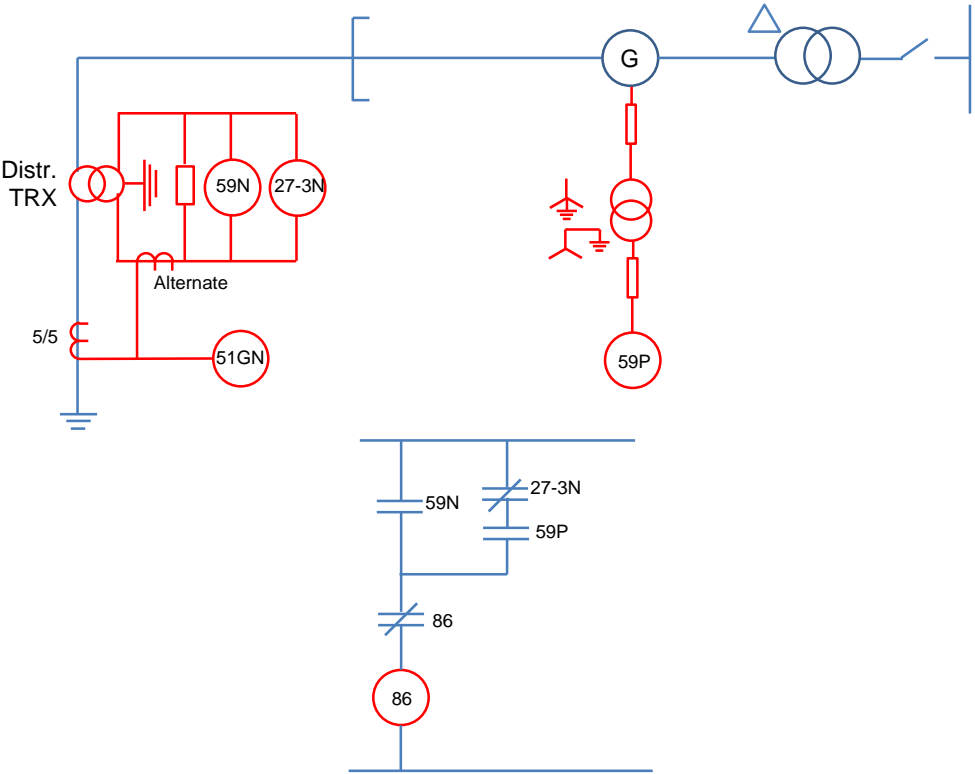

Figure 4. Unit connected case with high-resistance earthing

Protection presented in Figure 4 consists of a 59N overvoltage relay and a 27-3N third-harmonic under-voltage relay. As presented in Figure 5, an earth fault at the generator high voltage bushings elevates the sound phase line to earth voltages to a nominal 173% of normal line to neutral voltages. Also, the neutral to earth voltage will

increase to the normal phase-earth voltage levels. The closer the earth fault is to the generator neutral, the less the neutral to earth voltage will be. One way to detect this neutral shift is with the 59N relay (as shown in Figure 4) monitoring the generator neutral. The 59N relay will detect and protect the generator for earth faults over about 95% of the generator winding. The chosen 59N relay needs to be chosen so as to not react to third harmonic voltage generated during normal service. The 59N relay will not trip for faults near the generator neutral because of the decreased neutral shift during this type of fault.

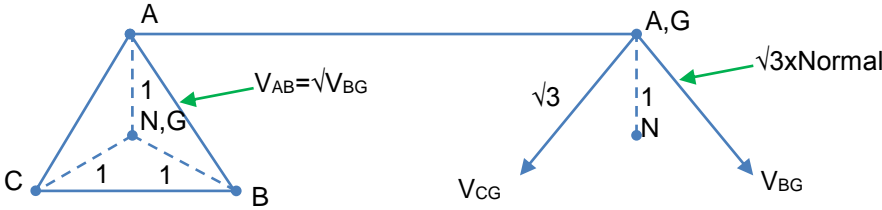

Figure 5. Neutral shift during earth fault on high impedance earthed system

Faults near the generator neutral may be discovered with the 27-3N. When high impedance earthing is used, a detectable level of third harmonic voltage will typically exist at the generator neutral, around 1-5% of generator line to neutral fundamental voltage. The level of third harmonic depends on generator design and may be very low in some machines (a 2/3 pitch machine will have considerably decreased third harmonic voltage). The level of harmonic voltage will likely come down at lower excitation levels and lower load levels. During earth faults near the generator neutral, the third harmonic voltage in the generator neutral is shorted to earth, causing the 27-3N to drop out (as shown in Figure 6). It is critical that the 27-3N have high rejection of fundamental frequency voltage.

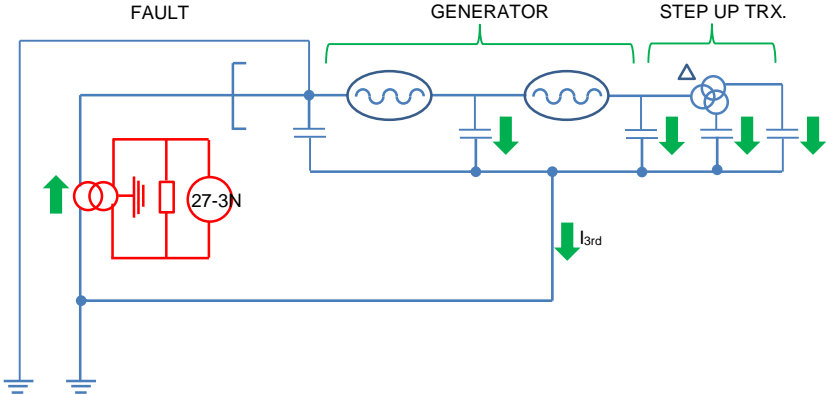

Figure 6. Earth fault near generator neutral decreases third-harmonic voltage in generator neutral, dropping out 27-3N

The 27-3N completes a monitoring function aside from its fault detection function. In the case an earthing system is shorted or an open occurs, the 27-3N drops out. The 59P phase overvoltage protection relay shown in Figure 4 supervises the 27-3N protection relay, so that the 86 lockout relay can be reset when the generator is out of operation. Otherwise, the field could not be used. Once the field is used and the 59P operates, the 27-3N protection is enabled. The 59P relay needs to be set for about 90% of rated voltage. An “a” contact of the unit breaker can be used instead of the 59P protection relay to supervise 27-3N tripping. Blocking the 27-3N until some level of forward power exists also has been done. Nevertheless, use of the 59P protection relay allows the 27-3N to provide protection prior to synchronization.

In order to give 100% stator winding coverage, the under voltage (27-3N) and overvoltage (59N) settings should overlap. For instance, if a generator-terminal fault creates 240V, 60 Hz across the neutral voltage relay (59N), a 1V pickup setting would allow all but the last $(1/240)*100 = 0.416\%$ of the winding to be covered by the overvoltage function. In the case, 20V third harmonic is created across the relay prior to a fault, a 1V third harmonic drop-out setting would give dropout for a fault up to $(1/20)*100 = 5\%$ from the neutral. Adjusting the 59N pickup too low or the 27N dropout too low may end in operation of the earth detection system during normal service. The third harmonic dropout level may be the most difficult to adjust, since its level depends on machine design and generator excitation and load levels. It is suggested to measure third harmonic voltages at the generator neutral during unloaded and loaded conditions prior to choosing a setting for the 27-3N dropout. In some generators, the third harmonic at the neutral may become so low during low excitation and low load levels, requiring blocking the 27-3N tripping mode with a supervising 32 under power element when the generator is operating unloaded. There is also certain level of third harmonic voltage present at the generator high voltage terminals. A predictable ratio will exist under all loading situations, even though this ratio may change if loading can create changes in third harmonic voltages. An earth fault at the generator neutral will affect this ratio, and this ratio change is another means to sense a generator earth fault. Two difficulties with this system are: problems with developing means to precisely detect low third harmonic voltages at the generator high voltage terminals in the presence of large fundamental frequency voltages, and issues with dealing with the changes in third harmonic ratio

under certain operating scenarios.

If the 59N protection relay is only used for alarming, the distribution transformer voltage ratio needs to be selected to limit the secondary voltage to the maximum continuous rating of the protection relay. If the protection relay is used for tripping, the secondary voltage could be as high as the relay's ten-second voltage rating. Tripping is suggested to minimize iron damage for a winding fault as well as minimizing the chance of a multi-phase short circuit. In the case, wye-wye voltage transformers are installed to the machine terminals, the secondary VT neutral should not be earthed in order to avoid tripping of 59N for a secondary earth fault. Instead, one of the phase leads needs to be earthed, leaving the neutral to float. This arrangement eliminates any voltage across the 59N protection relay for a secondary phase-earth fault. In the case, voltage transformer secondary neutral is earthed a line-ground VT secondary fault pulls little current, so the secondary fuse detects little current and does not trip. The fault seems to be a high impedance line to ground fault as seen by the generator neutral shift sensing relay (59N), leading to a generator trip. Optionally, assume that the voltage transformer corner (for example, phase A) has been earthed. In the case of phase B or C fault to earth, the fault will seem as a line-line fault, which will pull high secondary currents and will quickly clear the secondary fuse and prevent tripping of 59N. A neutral to earth fault will tend to trip the 59N, but this is a low probability event. An isolation voltage transformer is needed if the generator VTs would otherwise be galvanically connected to a set of neutral-earthed VTs. Three wye VTs need to be provided in the case an iso-phase bus (phase conductors separately enclosed) is used to protect against line-line faults on the generator terminals. The 59N protection relay in Figure 4 is subject to operation for a earth fault on the wye side of any power transformer connected to the generator. This voltage is created even though the generator connects to a delta winding because of the transformer inter-winding capacitance. This coupling is insignificant and its impact can ordinarily be ignored. Nevertheless this is not the case with the 59N installation because of the very high earthing resistance. The 59N overvoltage element time delay allows the protection relay to override external fault clearing.

Figure 4 presents a 51GN protection relay as a second means of sensing a stator earth fault. The application of a 51GN in addition to the 59N and 27-3N is justified,

since the most likely fault is a stator earth fault. An undetected stator earth fault would be catastrophic, ending in a multiphase fault with big current flow, which lasts until the field flux decays (for example 1 to 4s). The CT presented in Figure 4 could be replaced with a CT installed in the distribution transformer secondary, allowing application of a CT with a lower voltage rating. Nevertheless, the 51GN protection relay would then be inoperative in the case the distribution transformer primary becomes shorted. The CT ratio for the secondary-connected arrangement needs to provide, for a protection relay current, about equal to the generator neutral current. In either position, the protection relay pickup needs to be above the harmonic current flow during normal service. (Normally, harmonic current will be less than 1A but the protection relay may be set lower in the case relay filters harmonic currents and reacts only to fundamental currents.) Assuming a maximum fault current of 8A primary in the neutral and a relay set to pick up at 1A primary, 88% of the stator winding is protected. As with the 59N protection relay, the 51GN delay will allow it to override clearing of a high-side earth fault. An instantaneous overcurrent element can also be used, set at about three times the time-overcurrent element pickup, even though it may not coordinate with primary VT fuses that are installed to the generator terminals.

Multiple generators, shown in Figure 7, can be high resistance earthed, but the 59N protection relays will not be selective. An earth fault anywhere on the generation bus or on the individual generators will be detected by all 59N protection relays, and the tendency will be for all generators to operate. The 51N protection relay, when connected to a flux summation CT, will give selective tripping if at least three generators are in operation. In this situation, the faulted generator 51N relay will then see more current than the other 51N protection relays. The proper 51N will trip before the others because of the inverse characteristic of the protection relays. Application of the flux summation CT is limited to those situations where the CT window can accommodate the three cables. Fault currents are relatively low, so attention must be exercised in choosing proper nominal relay current level (e.g., 5A vs. 1A) and CT ratio. For instance, with a 30A fault level and a 50 to 5A CT, a 1A nominal 51N with a pickup of 0.1A might be applied. With two generators, each contributing 10A to a terminal fault in a third generator, the faulted-generator 51N relay senses $2 \cdot 10 / (50/5) = 2A$. Then the protection relay protects down to $(0.1/2) \cdot 100 = 5\%$ from the neutral.

When feeder cables are connected to the generator bus, an extra capacitance dictates a much lower level of earthing resistance than achieved with a unit-connected case. A lower resistance is needed to minimize transient over-voltages during an arcing fault.

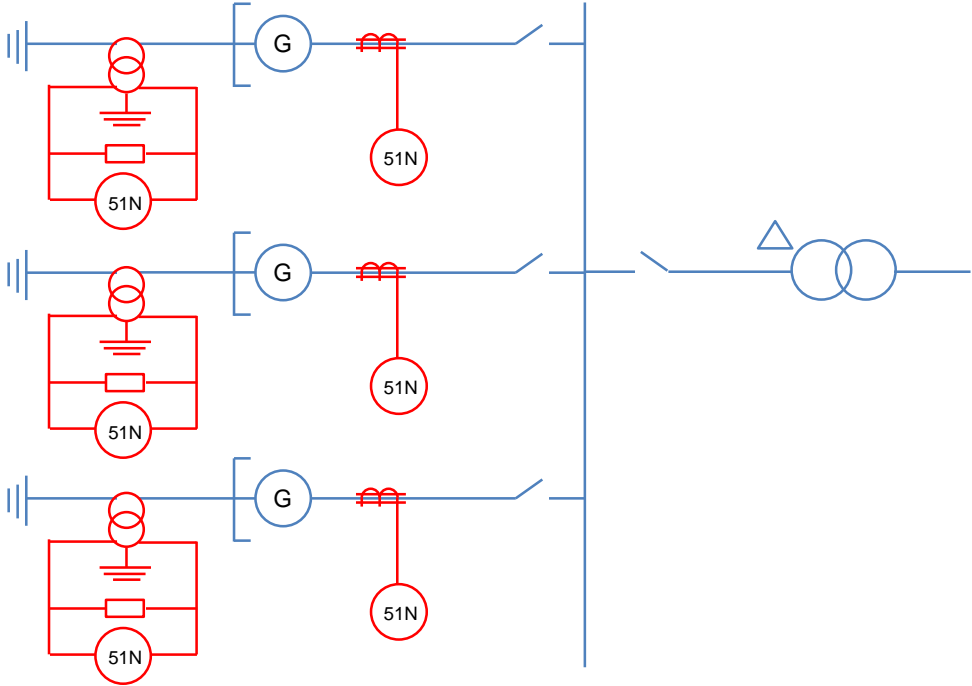

Figure 7. 59N protection relay operation with multiple generators will not be selective. 51N relays give selective protection if at least three machines are in service

Ground differential protection, as shown in Figure 8, is a good way to detect earth faults on low and medium impedance earthed units. It would more frequently be seen on generators that have the CTs needed for phase differential relaying. In Figure 8, the protective function is shown as 87N. An effort needs to be put to choose relay settings to trip for faults as low as 10% of maximum earth fault current levels. During external phase faults, considerable 87N operating current can happen when there is dissimilar saturation of the phase CTs due to high AC current or due to transient DC offset effects. At the same time the generator neutral current will still be zero, assuming balanced conductor impedances to the fault. One method to compensate for transient CT saturation is to have proper delay in the protection relay to ride through external high-current two-phase-earth faults.

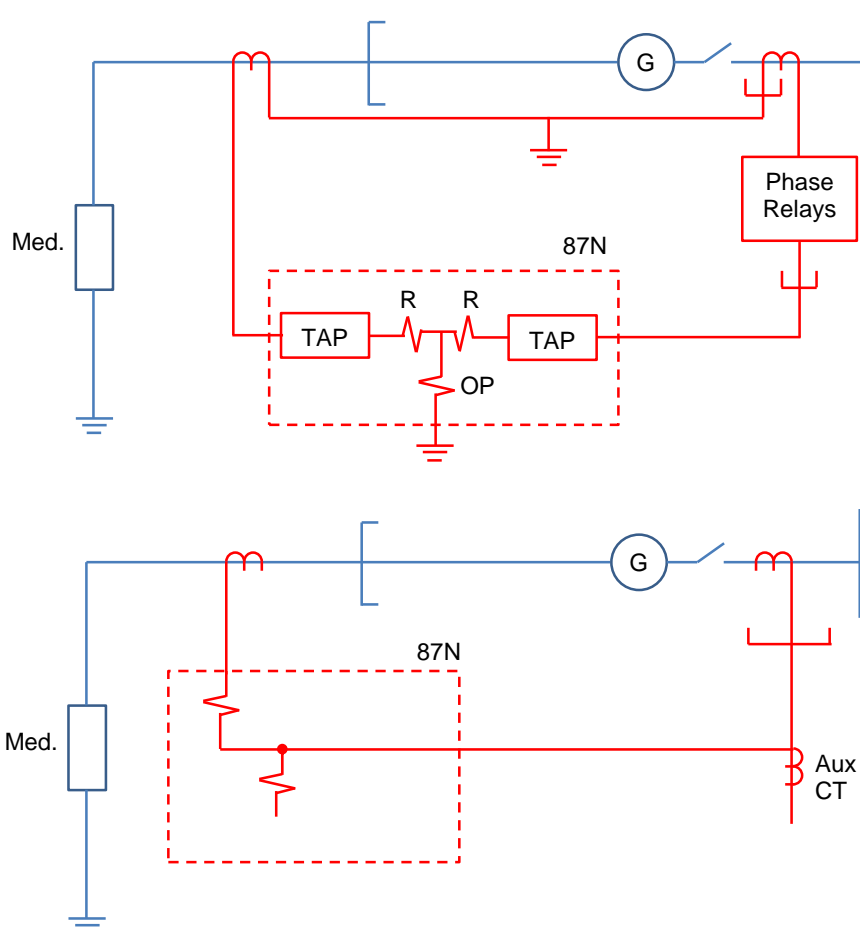

Figure 8. Medium level earthing with 87N earth differential protection

Line-Fault Protection

Figure 9 presents a simple method of discovering line faults, but clearing is delayed, since the 51 protection relay must be delayed to coordinate with external equipment. Since the 51 protection relay trips for external faults, it is not generator zone selective. It will trip for abnormal external operating conditions such as remote faults that are not adequately cleared by remote breakers. The 51 pickup needs to be set at around 175% of rated current to override swings due to a slow-clearing external fault, the large motor start, or the re-acceleration current of a group of motors. Transformer energization may also be put the generator to bigger than nominal current flow.

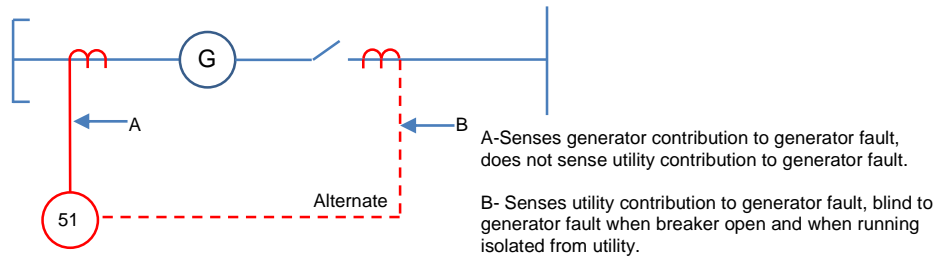

Figure 9. Line overcurrent protection (51) must be delayed to coordinate with external protection relays

Figure 10 presents an example of generator current decay for a 3 line fault and a line-line fault. For a 3 line fault, the fault current decays below 51 relay pickup level in roughly one second. If the relay 51 time delay can be selectively chosen to trip before the current drops to pickup, the relay will provide 3 phase fault protection. The current does not decrease as fast for a line-line or a phase earth fault and, therefore, allows the 51 relay more time to trip before current drops below pickup. Figure 10 assumes no voltage regulator boosting, even though the excitation system response time is unlikely to give significant fault current boosting in the fault first second. It also assumes no voltage regulator dropout due to excitation power loss during the fault. In the case generator is loaded before the fault, pre-fault load current and the higher excitation levels will give the fault with a bigger current level than shown in the Figure 10 curves. An estimate of the net fault current of a pre-loaded generator is a superposition of load current and fault current without pre-loading. For instance, assuming a pre-fault 1pu rated load at 30 degree lag, at one second the 3 phase fault value would be 2.4 times rated, rather than 1.75 times rated ($1@30^\circ + 1.75@90^\circ = 2.4@69^\circ$). Under these conditions, the 51 protection relay has more time to trip before current decreases below pickup.

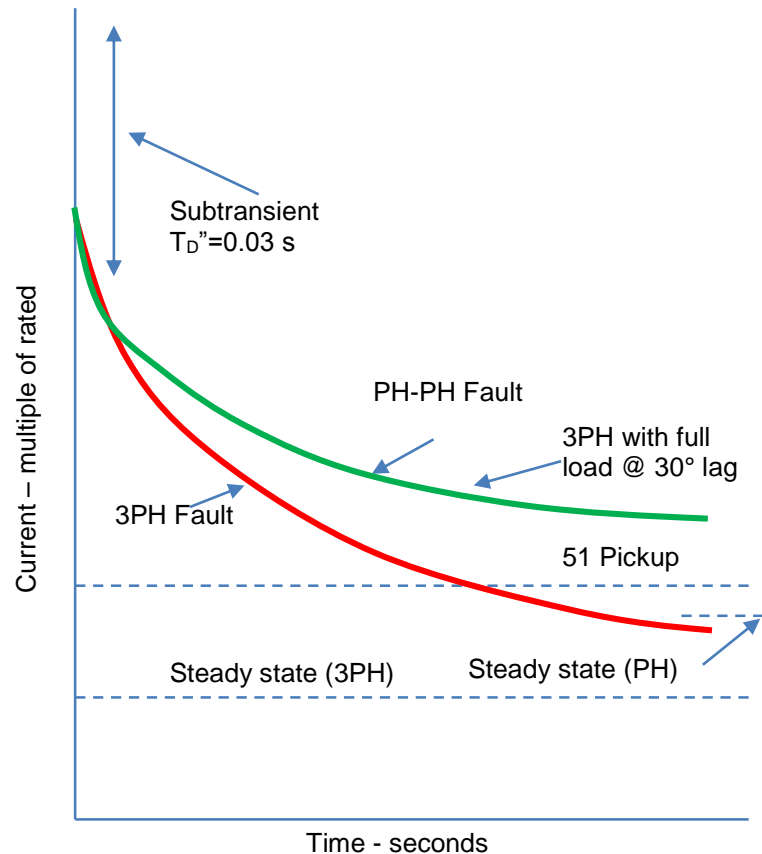

Figure 10. Generator fault current decay example for 3 phase and line-line faults at generator terminals – with no regulator boosting or dropout during fault and no re-fault load

Figure 9 presents the CTs on the generator neutral side. This location allows the protection relay to detect internal generator faults but does not detect fault current coming into the generator from the external system. Installing the CT on the generator system side introduces an issue of the relay not detecting a generator internal fault when the main breaker is open and when running the generator isolated from other generation or the power network. If an external source contributes more current than does the generator, installing CTs on the generator terminals, rather than neutral-side CTs, will increase 51 protection relay sensitivity to internal faults due to bigger current contribution from the external source. Nevertheless, the generator is unprotected in the case a fault happens with the breaker open or prior to synchronizing.

Voltage-restrained or voltage-controlled time overcurrent protection relays (51VR, 51VC) may be used as presented in Figure 11 to remove any issues about ability to

trip before the generator current drops too low. The voltage feature allows the relays to be set below nominal current. The voltage restrained approach causes the pickup to decrease with decreasing voltage. For instance, the protection relay might be set for about 175% of generator rated current with rated voltage used, at 25% voltage the relay picks up at 25% of the relay setting. The voltage controlled system inhibits operation until the voltage drops below a preset voltage. It needs to be set to operate below about 80% of nominal voltage with a current pickup of about 50% of generator rated. Since the voltage-controlled system has a fixed pickup, it can be more readily coordinated with external protection relays than can the voltage-restrained type. The voltage-controlled system is suggested since it is easier to coordinate. Nevertheless, the voltage restrained system will be less susceptible to operation on swings or motor starting conditions that decrease the voltage below the voltage controlled under voltage unit dropout setting.

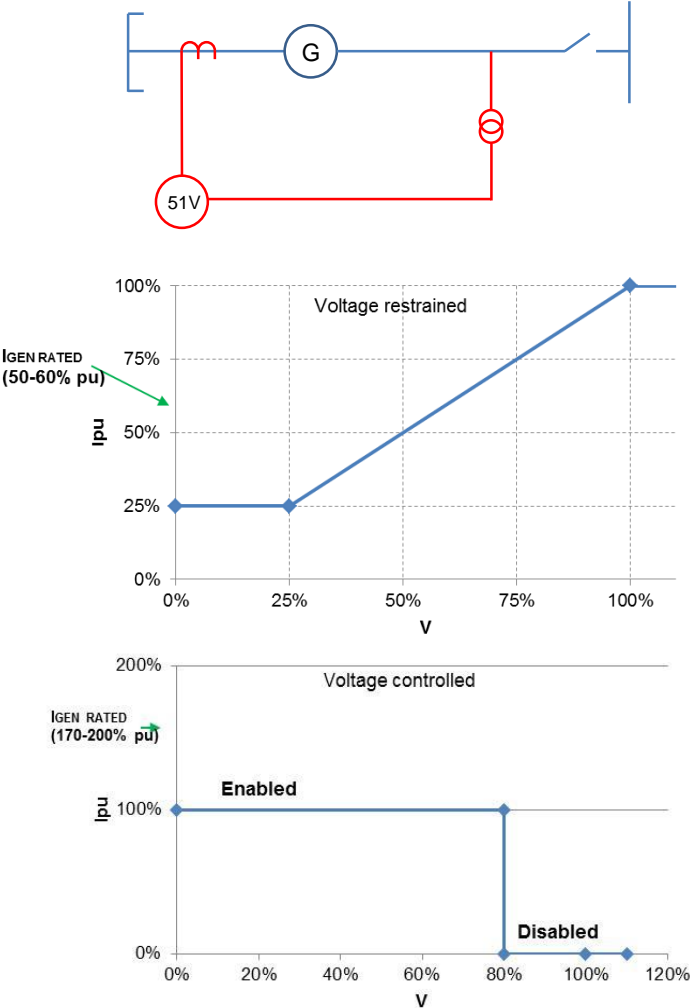

Figure 11. Voltage restrained or voltage controlled time-overcurrent line fault protection

Figure 12 resolves concerns about the generator current decay rate by applying an instantaneous overcurrent relay (50) on a flux summation CT. In that case the CT window can accommodate cable from both sides of the generator. The protection relay does not react to generator load current nor to external fault conditions. The instantaneous overcurrent protection relay (50) works as a line differential relay (87) and gives high-speed sensitive protection. This system provides high sensitivity. For example, it would be possible to detect fault currents as low as 1-5% of generator full load current. It is typical to install 50/5 CTs and to use 1A nominal relaying. A low CT ratio introduces critical saturation issues (for example, a 5,000A primary fault may try to drive a 500A secondary on a 50/5 CT). The CT burden needs to be low to prevent CT saturation during internal faults that may tend to highly overdrive the CT secondary. The 51 protection relay presented in Figure 12 is used for back-up of external faults and as back-up for the 50 protection relay.

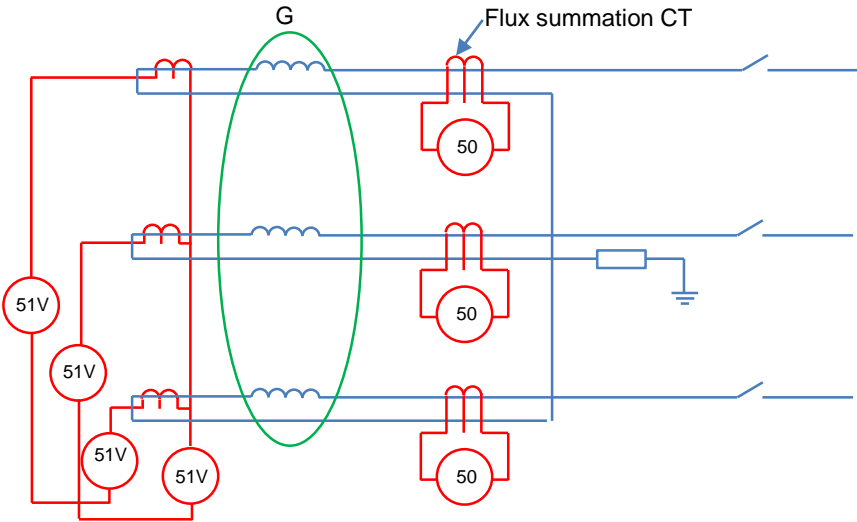

Figure 12. Flux summation protection relay (50) gives sensitive, high-speed, selective differential protection (87)

The 87G protection relay shown in Figure 13 is installed to respond to line differential currents from two sets of CTs. In some installations, it may include a unit differential that includes the step-up transformer. In contrast to a 51 or 51V protection relay that monitors only one CT, the 87G protection relay reacts to both the generator and external contributions to a generator fault. Because of the differential connection arrangement, the protection relay is immune, except for transient CT saturation effects, to operation due to generator load flow or external faults. Hence, it can provide sensitive, high speed protection. While the CTs have to be of the same ratio,

they do not need to be matched in performance, but the minimum pickup needs to be raised as the degree of performance mismatch increases. A minimum pickup of 0.1 times tap or 0.4A (87G) is representative of a suggested setting for a moderate mismatch in CT quality and burden. Figure 13 also presents 51V protection relays to back up the 87G and external protection relays and breakers.

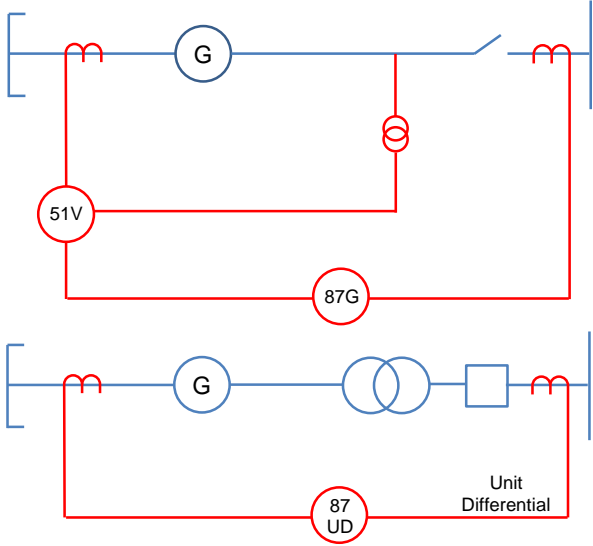

Figure 13. 87G gives sensitive, high-speed coverage, 51V gives back-up for 87G and for external protection relays. 87G may wrap step up transformer (unit differential)

Another way to sense external faults is with impedance relaying. Impedance relaying divides current by voltage on a complex number plane. Typical examples are shown in Figure 14 and Figure 15. Such relaying is inherently quicker than time-overcurrent relaying. In the most typical application of impedance relaying, the tripping zone is the area covered by a "Mho" circle on the R-X plane that has a diameter from the origin (the CT, VT location) to some remote set point on the R-X plane. In the case, fault impedance falls within the zone, the relay operates. Multiple zones may be applied, with delays on all zones as appropriate for coordinating with phase relays. Impedance relaying is highly directional. When the CT is on the neutral rather than at the VT, the protection relay will sense faults both in the generator and in the remote system. This is shown in Figure 14.

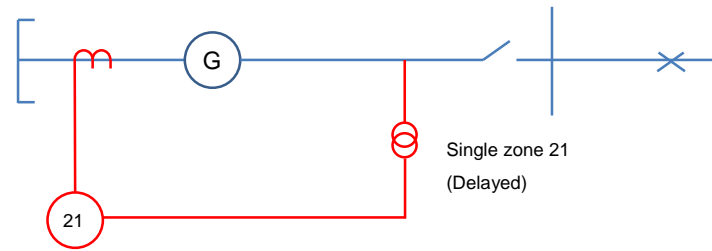

Figure 14. Impedance protection relay, detecting generator and remote line faults

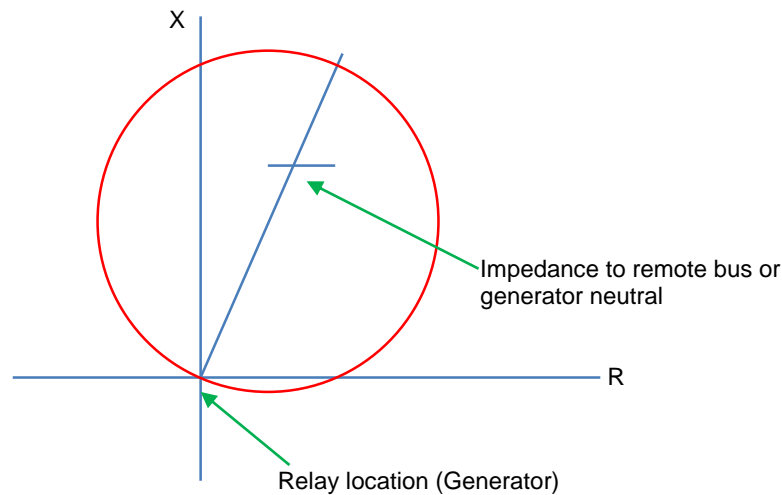

Figure 15. Impedance protection relay, detecting remote line faults

Reverse Power Protection

The reverse-power protection relay (32) shown in Figure 16 detects real power flow into the generator, which will happen if the generator loses its prime-mover input. Since the generator is not faulted, CTs on either side of the generator would give the same measured current.

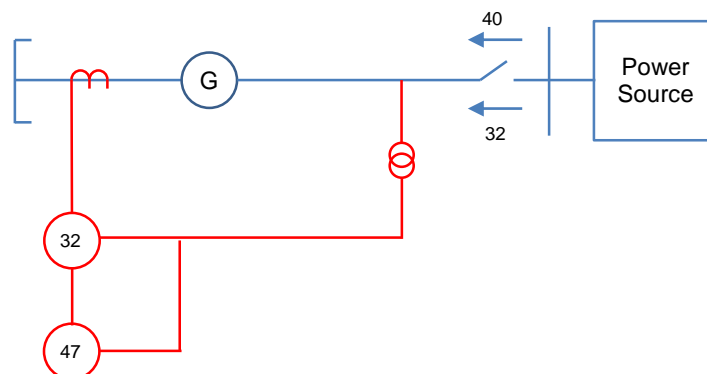

Figure 16. Anti-motoring (32) loss of field (40) generator protection

In a steam-turbine installation, the low pressure blades will overheat with the lack of steam flow. Diesel and gas-turbine installations draw large amounts of motoring

power, with possible mechanical issues. In the case of diesels, the fire hazard and/or explosion may happen due to unburnt fuel. Hence, anti-motoring protection is suggested whenever the unit may be connected to motoring power source. Where a non-electrical protection type is applied, as may be the case with a steam turbine unit, the 32 protection relay gives a means of supervising this condition to stop opening the generator breaker before the prime mover has shut down. Time delay needs to be set around 5-30 seconds, giving sufficient time for the controls to pick up load upon synchronizing when the generator is initially slower than the system. Since motoring can happen during a large reactive-power flow, the real power has to be measured at low power factors. Figure 17 presents the use of two reverse-power protection relays: 32-1 and 32-2. The 32-1 protection relay supervises the generator tripping of devices that can wait until the unit starts to motor. Over-speeding on large steam-turbine units can be avoided by delaying main and field breaker tripping until motoring happens for non-electrical and selected electrical conditions. Protection relay 32-1 needs to be delayed for roughly 3 seconds, while relay 32-2 needs to be delayed by roughly 20 seconds. Time delay would be based on generator response during generator power swings. Protection relay 32-2 operates directly for motoring situations that were not started by lockout relay 86NE — for example, governor control malfunction.

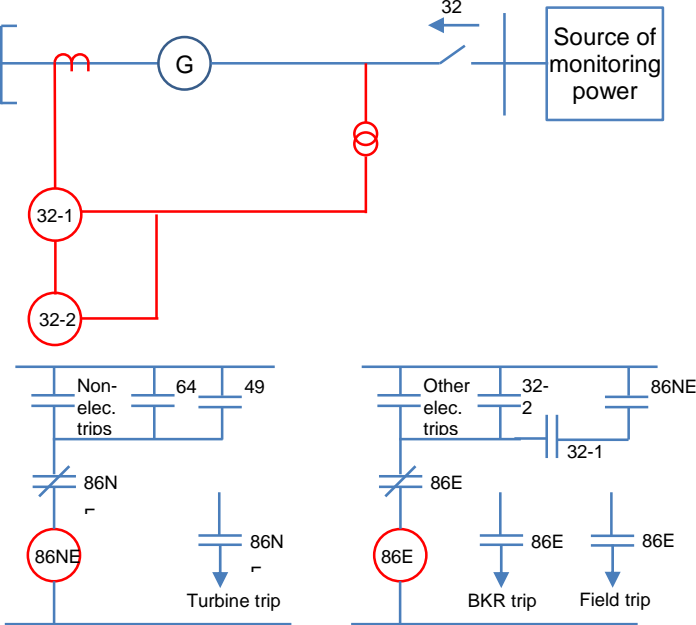

Figure 17. Reverse power relay 32-1 stops load rejection before prime mover shutdown for selected trips. Relay 32-2 trips if motoring is not accompanied by AN 86NE operation

Loss-of-Field Protection

Loss of excitation can partly be discovered within the excitation system itself by monitoring for loss of field voltage or current. For generators that operate in parallel with power system, the preferred way is to monitor field loss at the generator terminals. When a generator loses excitation power, it seems to the system as an inductive load, and the machine starts to absorb a considerable amount of VARs. Field loss may be sensed by monitoring for VAR flow or apparent impedance at the generator terminals.

The power diagram in Figure 18 presents characteristic with a representative setting, a generator thermal capability curve, and an example of the trajectory following an excitation loss. The first diagram quadrant is applicable for lagging power factor operation (generator provides VARs). The trajectory starts at point A and continues into the leading power factor zone (4th quadrant) and can surpass the unit thermal capability. A trip delay of roughly 0.2-0.3 seconds is suggested to prevent unnecessary trips due to other transient conditions. A second high speed trip zone might be included for serious under-excitation situations.

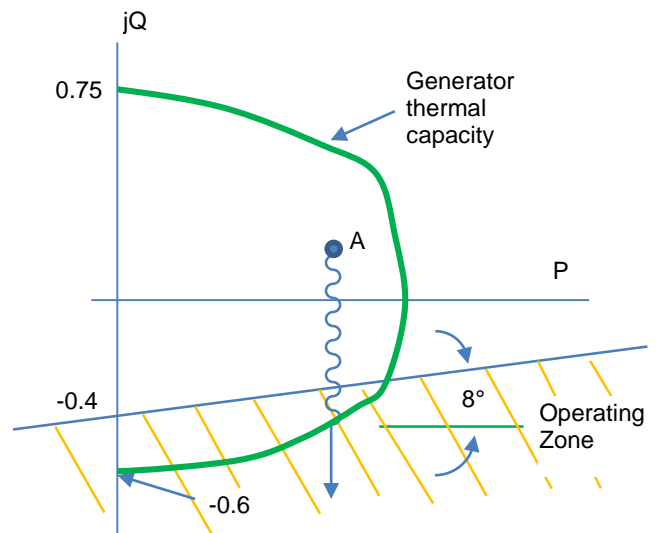

Figure 18. Field loss - the power trajectory shifts from point A into the fourth quadrant. Once impedance relaying is applied to detect excitation loss, the trip zone is commonly marked by a mho circle centered about the X axis, offset from the R axis by $X'_d/2$. Typically, two zones are used, a high speed zone and a time delayed zone.

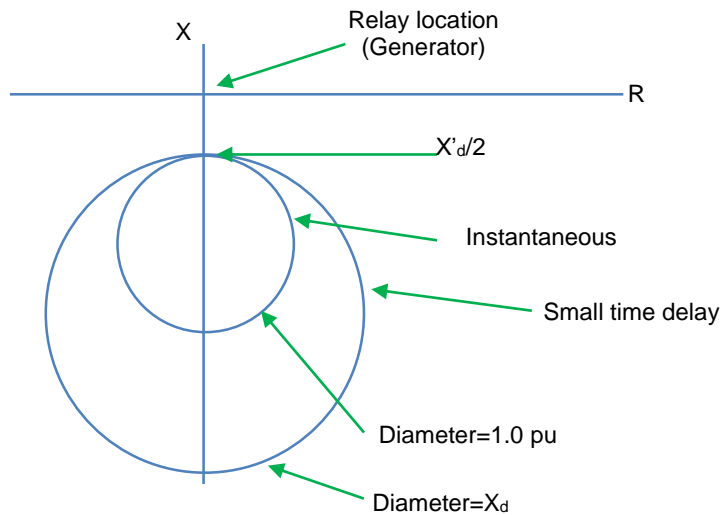

Figure 19. Excitation loss using impedance relay

With complete excitation loss, the unit will finally work as an induction generator with a positive slip. Since the unit is operating above synchronous speed, excessive currents can flow in the rotor which can lead to overheating of elements that are not made for such operation. This heating cannot be discovered by thermal relay 49, which is typically installed to discover stator overloads. Rotor thermal capability can also be surpassed for a partial excitation reduction due to an operator error or regulator malfunction. In the case a unit is initially producing reactive power and then draws reactive power upon loss of excitation, the reactive swings can considerably depress the voltage. Also, the voltage will oscillate and adversely affect sensitive loads. In the case, the unit is big in comparison to the external reactive sources, system instability can happen.

Thermal Protection

Figure 20 presents the relay that is connected to a resistance-temperature detector, embedded in a stator slot. Protection relay models are available for either copper or platinum RTDs. The protection relay is equipped with a constant-current source to generate a voltage across the RTD and includes the means to measure that voltage using separate leads. The protection relays have trip and alarm set points, and can provide readout of present temperature.

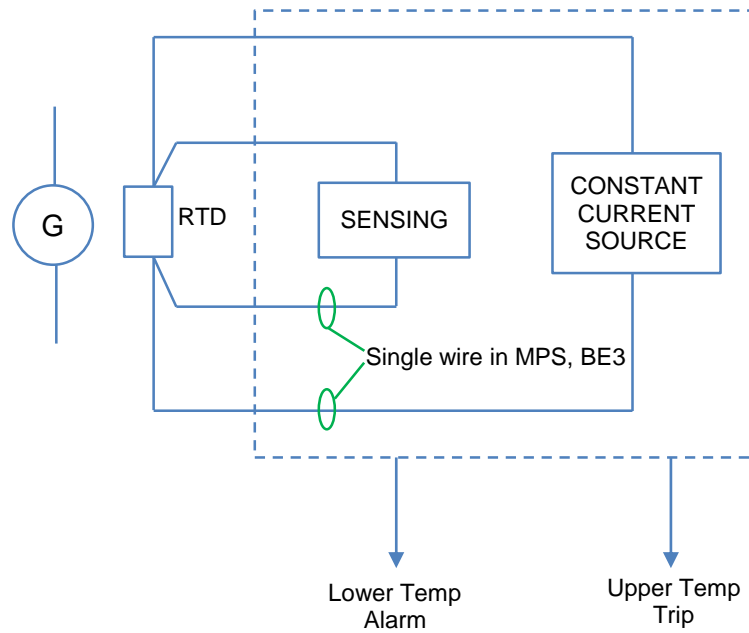

Figure 20. Generator stator temperature protection

Loss of VT Detection

Typically, two methods used to discover loss of VTs. These are:

- Voltage balance between two VTs
- Voltage-current comparison logic.

Figure 21 presents the application of two sets of VTs on the generator terminals, with the 60FL comparing the output of the two VTs. One set supplies the voltage regulator while the other supplies the relays. If the potential reduces or is lost from VT No. 1, the relay disables the voltage regulator. In the case source No. 2 fails, relay tripping of the 21, 27, 59N, and 47 is blocked. In certain installations 25, 32, and 40 elements are also blocked. Over-excitation relay (24), phase overvoltage (59), and frequency relaying (81), do not have to be blocked, since potential loss leads toward non-operation of these functions.

A second way of discovering fuse loss is by comparing voltage and current as shown in the Figure 22. In the case of a single phase or two phase fuse loss, voltage imbalance happens without the corresponding current imbalance that would exist during a fault. In the case of a three phase fuse loss, total voltage loss happens without the corresponding three phase current flow that would happen during a fault. To stop 60FL from being declared during loss of station power, it may be required to

allow a 3 phase 60F to be declared only when low level of load current exists.

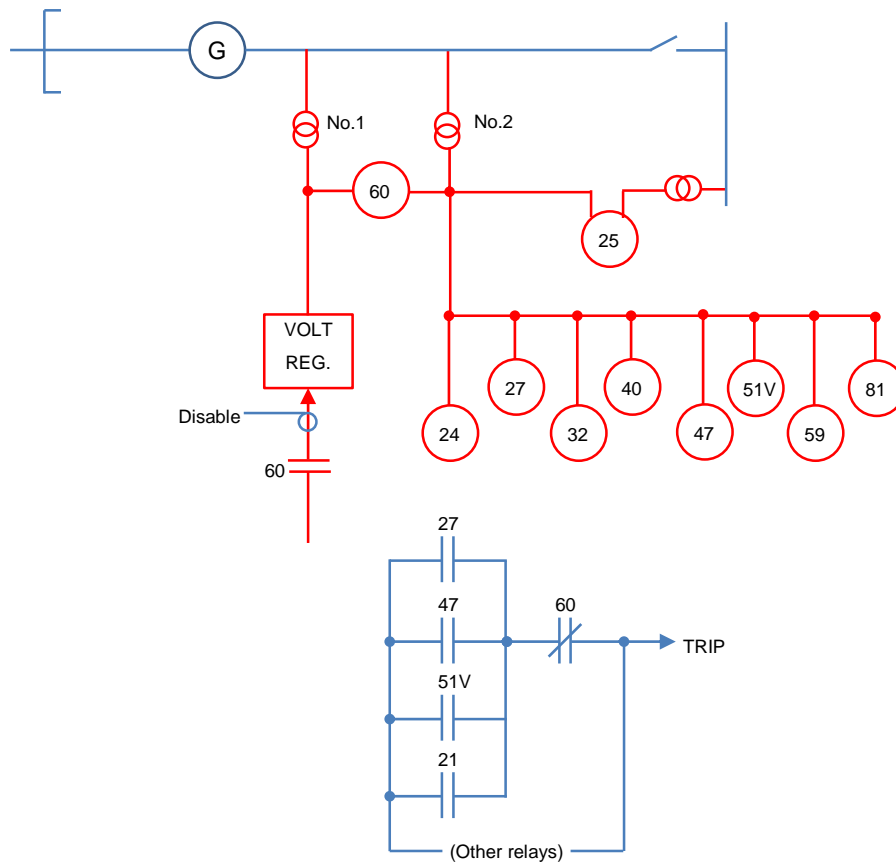

Figure 21. Different voltage protection elements; Voltage-balance relay (60) discovers potential supply failure

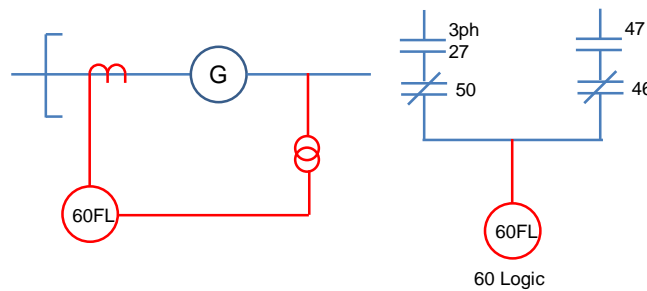

Figure 22. Loss of fuse detection, optional arrangement

Over/Under Voltage and Over-excitation Protection

Over-excitation can happen due to bigger than rated voltage, or rated or lower voltage at less than nominal frequency. For a certain flux level, the machine voltage output will be proportional to frequency. Since maximum flux level is designed for normal frequency and voltage, when a machine is at decreased speed, maximum voltage is proportionately decreased. A volts/hertz protection relay (24) reacts to

excitation level as it impacts thermal stress to the generator (and to any transformer tied to that generator). IEEE C50.13 standard defines that a generator needs to permanently withstand 105% of rated excitation at full load. Once the unit is offline, and with voltage-regulator control at decreased frequency, the generator can be overexcited in the case the regulator does not include an over-excitation limiter. Over-excitation can also happen, especially with the unit off line, in the case the regulator is out of operation or defective. In the case voltage balance supervision (60) is not installed and a fuse blows on the regulator ac potential input, the regulator would cause over-excitation. Loss of AC potential may also fool the operator into developing excessive excitation. The 24 protection relay can only protect for over-excitation that is caused by erroneous voltage indication in situations the 24 relay is connected to an AC potential source different than that used for the regulator. Figure 23 presents the relation among relay inverse squared characteristics and generator and transformer withstand capability. The transformer and generator manufacturers need to provide the specific capabilities of particular units.

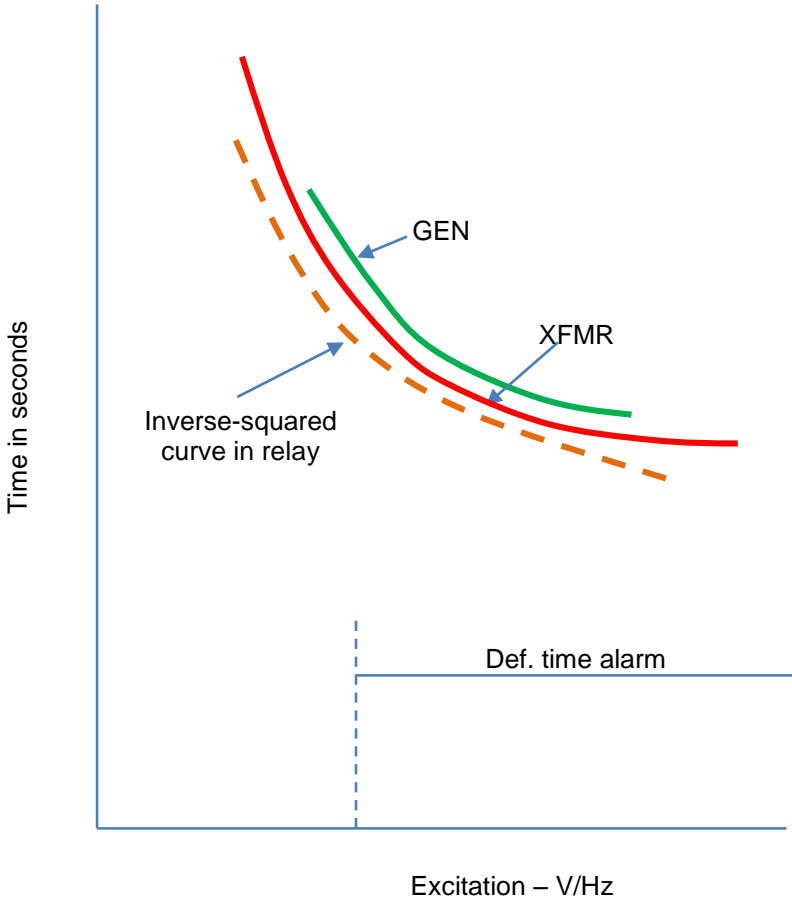

Figure 23. Combined transformer/generator over-excitation protection using both the inverse squared tripping

Phase over (59) and under (27) voltage protection relaying also serves as a backup for excitation system issues. Under-voltage relaying also serves as fault detection relaying since faults tend to decrease the voltage.

Off-Frequency Service

Diesel engines can be operated off rated frequency, and minimal protection is needed. Typically, turbine controls provide protection for off frequency situations, but protection relaying needs to be installed to protect the turbine and generator during control system failure. Frequency relays are typically installed with steam-turbine units, especially to minimize turbine blade fatiguing. Standard IEEE C37.106 addresses abnormal frequency service and presents typical frequency operating limits developed by different generator manufacturers. The simplest relay installation would be a single under-frequency stage, but a multiple stage and multiple set point scheme may be beneficial. Each set point may be programmed to recognize either over-frequency or under-frequency. Another typical need for frequency relaying is the detection of generation that has become isolated from the larger power network. When a generator is connected to larger power network, generator frequency is held closely to system frequency. Upon islanding, the generator frequency considerably changes since the governor operates to adjust generator power output to local load. In the case the generator frequency differs from nominal, islanding is declared and either the generator is tripped or the point of common coupling with the utility is switched off.

Inadvertent Energization Protection

Inadvertent energization can happen from a breaker interrupter flashover or a breaker close initiation while the unit is at standstill or at low speed. The quick acceleration can do considerable damage, especially if the generator is not quickly de-energized. While relays installed for other purposes may finally respond, they are typically not considered dependable for responding to such an energization. Figure 24 and Figure 25 show two arrangements of detecting the energization of a machine at standstill or at a speed considerably lower than nominal. This could be caused by single-phase energization due to breaker-interrupter flashover or 3 phase

surges, it can still give fast tripping for generator faults, since the 67 relays do not have to be coordinated with external protection. Figure 25 presents the operating range for phase A current (I_a) with respect to phase B to C voltage. This range is fixed by the 60 degree characteristic angle and the ± 45 degree limits set on the operating zone.

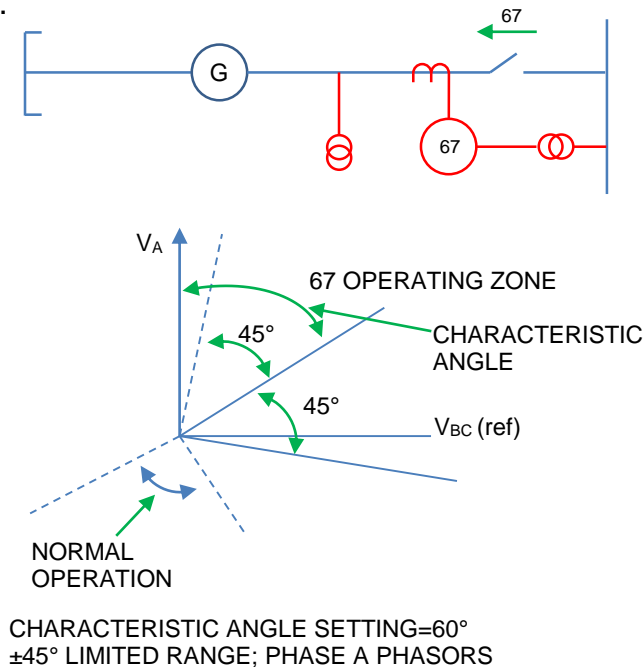

Figure 25. Directional overcurrent relays sense inadvertent energization

Negative Sequence Protection

Negative sequence stator currents, created by fault or load unbalance, create double frequency currents into the rotor that may finally overheat elements that are not made to sustain such currents. Series unbalances, such as untransposed transmission lines, generate some negative-sequence current (I_2) flow. The biggest series unbalance is an open phase, such as an open breaker pole. ANSI C50.13-1977 standard defines a continuous withstand of 5 to 10% of rated current which is dependent on the generator size. These values can be surpassed with an open phase on a heavily-loaded generator. Relays protect against this situation, providing negative sequence inverse-time protection shaped to match the generator short-time withstand capability in the case a protracted fault happens. This is an unlikely scenario, since other fault sensing relays tend to clear faults faster, even if primary protection fails. Figure 26 presents the 46 relay connection. CTs on either side of the generator can be installed, since the relay protects for situations external to the

generator. Typically, relay alarm unit notifies the operator to the existence of a dangerous condition.

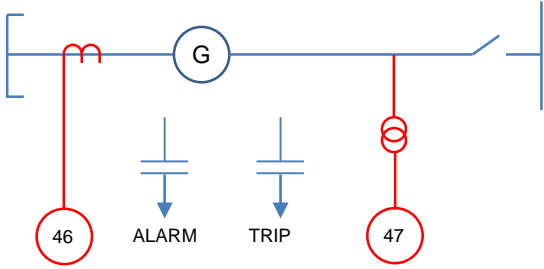

Figure 26. Negative-sequence current relay (46) protects against rotor overheating caused by a series unbalance or protracted external fault. Negative sequence voltage relay (47) also responds

Negative sequence voltage (47) protection, while not as typically installed, is also one of the methods to detect system imbalance as well as, in some cases, a generator misconnection to a system to which it is being paralleled.

Out of Step Generator Protection

Once a generator pulls out of synchronism with the system, current will increase relatively slowly in comparison to the instantaneous change in current associated with a fault. The out-of-step protection relay uses impedance methods to detect this situation. The protection relay will detect an apparent load impedance swing since impedance moves from Zone 1 to Zone 2 (as shown in Figure 27). The time needed for the load impedance to traverse from Zone 1 to Zone 2 is used to decide if an out of step condition is happening. Moving impedance is recognized as a swing rather than a fault, so adequate fault detection relaying may be blocked.

Selective Tripping and Sequential Tripping

For some generators, it is a common practice to selectively trip the prime mover, the field, and the generator breaker which depends on the type of fault that is detected. For example, in the case generator is protected by a 51V and an 87G, and only the 51V operates, it may be assumed that the fault is external to the generator. Therefore, the 51V only trips the generator breaker and quickly pulls back the

excitation governor and prime mover set points. Nevertheless, if there is no 87G, the 51V trips the complete unit. Sequential tripping used for orderly shutdown is also associated with this concept. To prevent generator overspeeding during shutdown, sometimes the prime mover is first tripped and then the main breaker is tripped. This is done only after a reverse power relay checks the prime mover has stopped supplying torque to the generator.

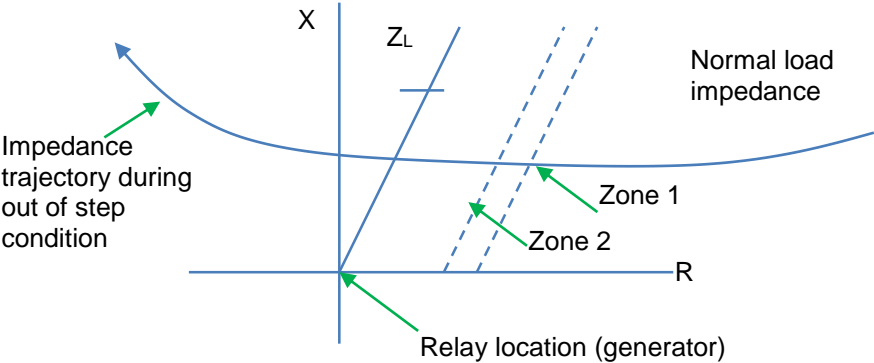

Figure 27. Out of step relaying (78)

Auto Synchronizing and Synchronism Check

Prior to connecting a generator to the power network, it is crucial that the generator and system frequency, voltage magnitude, and phase angle be in alignment. This is known as synchronism checking. Typical parameters are presented in Figure 28. Typical installations call for no more than 6 RPM error, 2% voltage amplitude difference, and no more than 10° phase angle error before closing the breaker. Auto synchronizing (25A) function refers to a system to automatically bring a generator into synchronism with the power network. This process involves sending voltage and speed raise and lower commands to the voltage regulator and prime mover governor. When the system is in synchronism, the auto-synchronizing relay is designed to send a close command in advance of the zero phase angle error point to compensate for breaker close delays. The 25 relay, which is typically set to supervise the 25A and manual synchronizing function, typically is set less tight than the 25A so as to coordinate with the actions of the 25A.

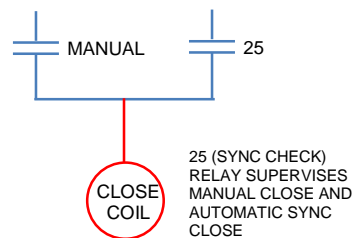
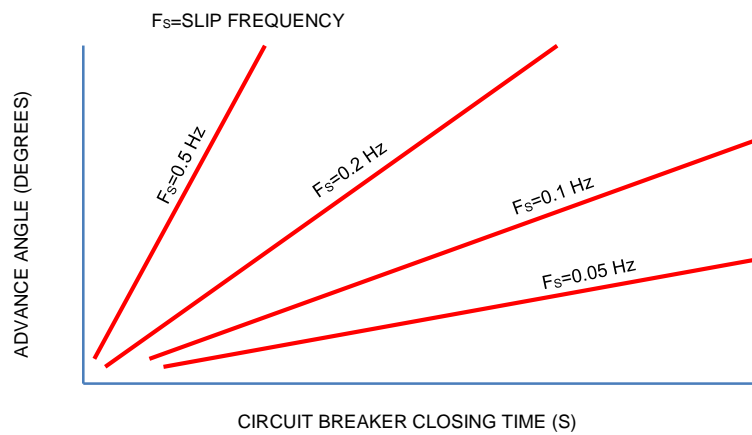
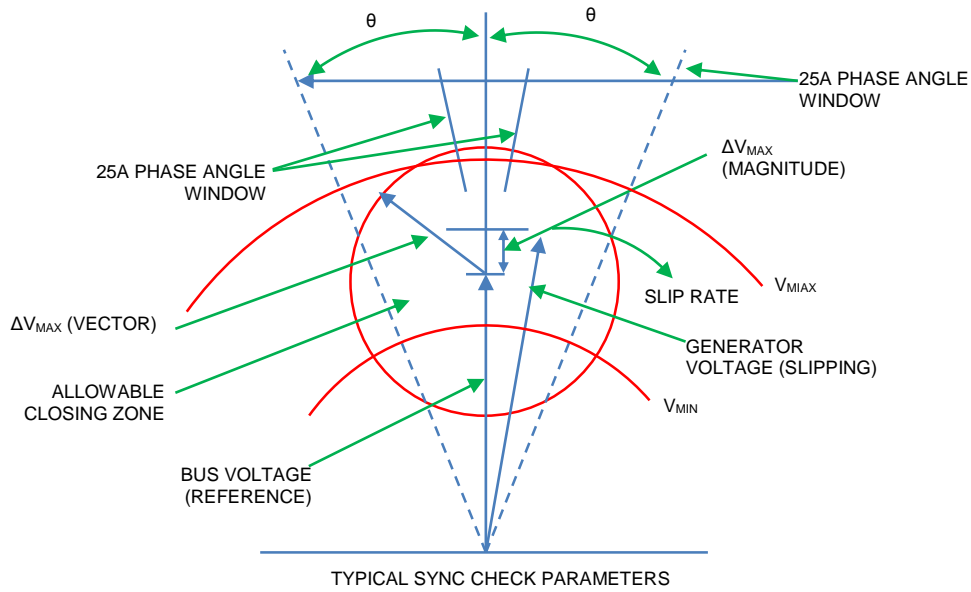

Figure 28. Synchronizing parameters: slip, advance angle, and breaker closing time

Application Examples

Figure 29 through Figure 33 show protection application examples. Figure 29 shows bare-minimum protection, with only overcurrent protection. Generators with such minimum protection are not common in an era of microprocessor-based multifunction protection relays. Such protection would be encountered only on very small (<50kVA)

generators that are typically used for standby power that is never paralleled with the power network or other generators. It may seem as a disadvantage to use CTs on the neutral side, since the protection relays may trip faster with CTs on the terminal side. The increase in speed would be the result of a bigger current contribution from external sources. Nevertheless, in the case CTs are installed on the generator terminal side, there will be no protection before putting the generator on line. This is not suggested since a generator with an internal fault could be destroyed when the field is applied.

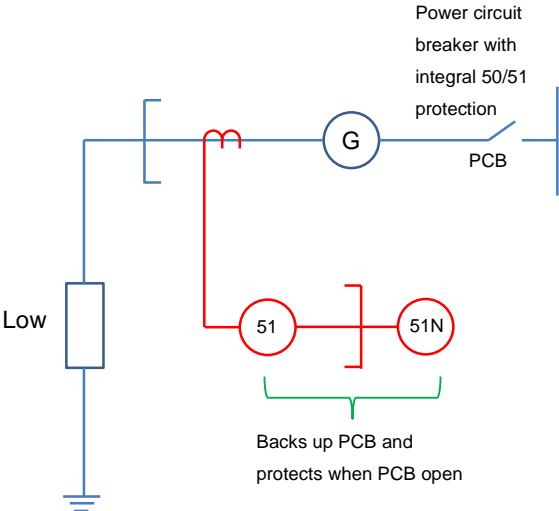
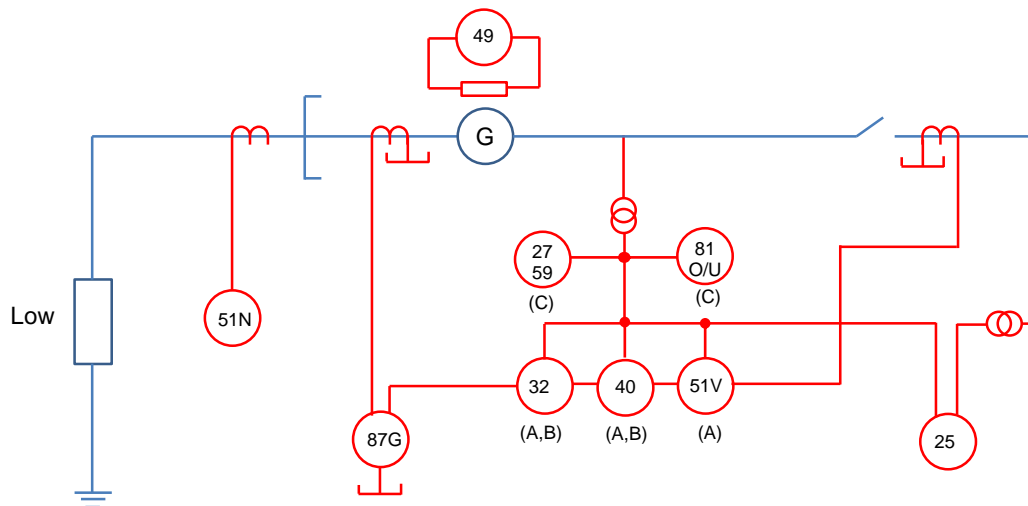

Figure 29. Generator bare minimum protection (low impedance earthing)

Figure 30 presents the suggested minimum protection with low-resistance earthing. It uses differential protection, which gives fast, selective response, but differential protection becomes less typical as generator size decreases below 2MVA, on 480V units and on generators that never work in parallel with other generators. The differential relay reacts to fault contributions from both the generator and the external network. While the differential relay is quick, the generator field slow decay will cause the generator to continue supplying current into a fault. Nevertheless, fast relay operation will interrupt the external source contribution, which may be bigger than the generator contribution. Quick disconnection from the external source allows quick restoration of normal voltage to loads and may reduce damage and repair expenses.



- (A) Connect to neutral side CTs if no external power source or no 87B.
- (B) Omit if no external power source
- (C) Less critical

Figure 30. Recommended minimum protection example (low impedance earthing)

The differential relay (87G) may protect for earth faults which depends on the earthing impedance. The 51N protection relay presented in Figure 30 provides back-up protection for the 87G or will be the primary protection in the case the differential relay (87G) is not sensitive enough for the ground current level.

The 51V voltage-controlled or voltage-restrained time overcurrent relay is shown on the CT on the high voltage/system side of the generator, as shown in Figure 30. This allows the protection relay to sense system contributions to a generator fault. It gives back-up for the differential relay (87G) and for external relays and breakers. Since it is supervising CTs on the generator system side, it will not give any back-up coverage prior to having the unit on line. In the case there is no external source, no 87G, or if it is desired that the 51V provide generator protection while the breaker is open, connect the 51V to the neutral-side CTs. Figure 30 presents three relays sharing the same CTs with a differential relay. This is fine with solid state and numeric protection relays, because their low burden will not considerably degrade the differential relay protection quality. The typical CT is not a likely failure point of all connected relaying. A CT wiring error or CT short is unlikely to disable both the 87G and 51V relays. Rather, a shorted CT or defective connection will unbalance the differential circuit and cause the 87G to operate. Independent CTs need to be used to give improved back-up protection, even though this seems to be a minimal benefit. Nevertheless, a separate CT is used for the 51N protection relay that gives protection

Figure 32 presents minimum basic protection for a high impedance earthed generator. It is different from Figure 30 only in the earth relay protection and the earthing method. The voltage elements 59N/27-3N give the only earth protection, since the earth fault current is too small for phase differential relay (87G) operation. The 59N protection relay will not be selective if other generators are in parallel, since all the 59N protection relays will detect an earth fault and operate at the same time. If three Phase-Ground Y-Y VTs were installed in Figure 32, the 27 and 59 could give additional extra fault protection, and an extra generator terminal 59N earth shift relay could be used.

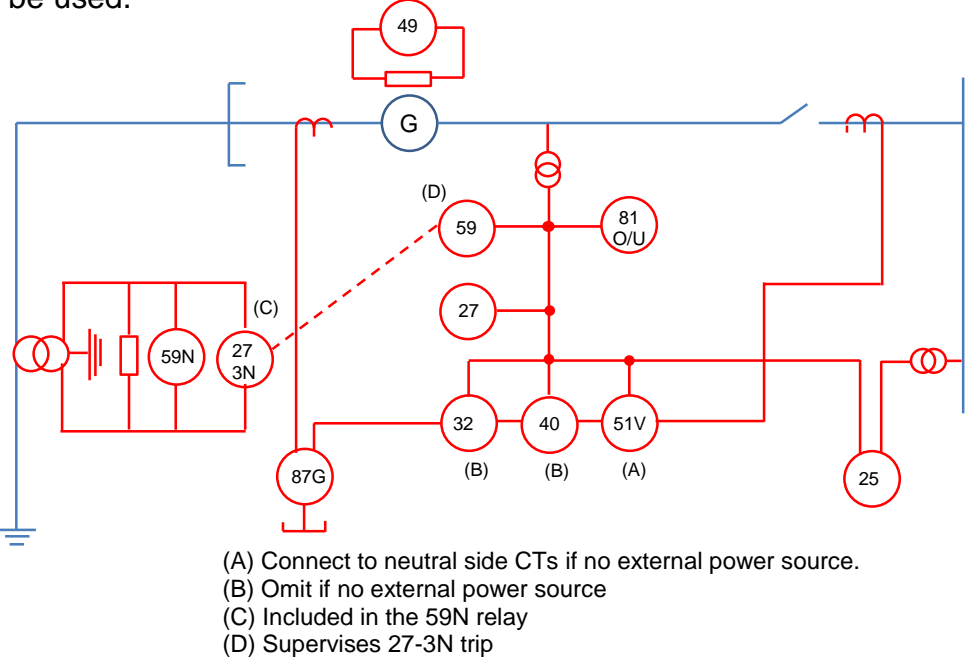

Figure 32. Recommended minimum protection (high resistance earthing)

Modern relays typically include a third harmonic under-voltage function (27-3N), that gives supervision of the earthing system, protects for faults near the generator neutral, and senses a shorted or open connection in the generator earth connection or in the distribution transformer secondary circuit. Figure 33 presents the application of extra relays for extended protection: over-excitation relay (24), negative sequence overcurrent and overvoltage relay (46 and 47), ground-overcurrent relay (51GN), voltage-balance relay (60), field-ground relay (64F), frequency relay (81) and the 27/50/ 62 relay combination for inadvertent energization protection. Relay 51GN gives an additional means of discovering stator earth faults or faults in the generator connections or faults in the delta transformer windings. Differential relay 87T and sudden-pressure relay 63 protect the unit step-up transformer. Relay 51N gives backup for external earth faults and for faults in the high voltage transformer windings

and leads. This protection relay may also react to an open phase condition or a breaker-interrupter flashover that energizes the generator. The 51N protection relay will be very slow for the flashover case, since it must be set to coordinate with external protection relays and is a last resort backup for external faults. Figure 33 presents wye-connected VTs, adequate with an isolated-phase bus.

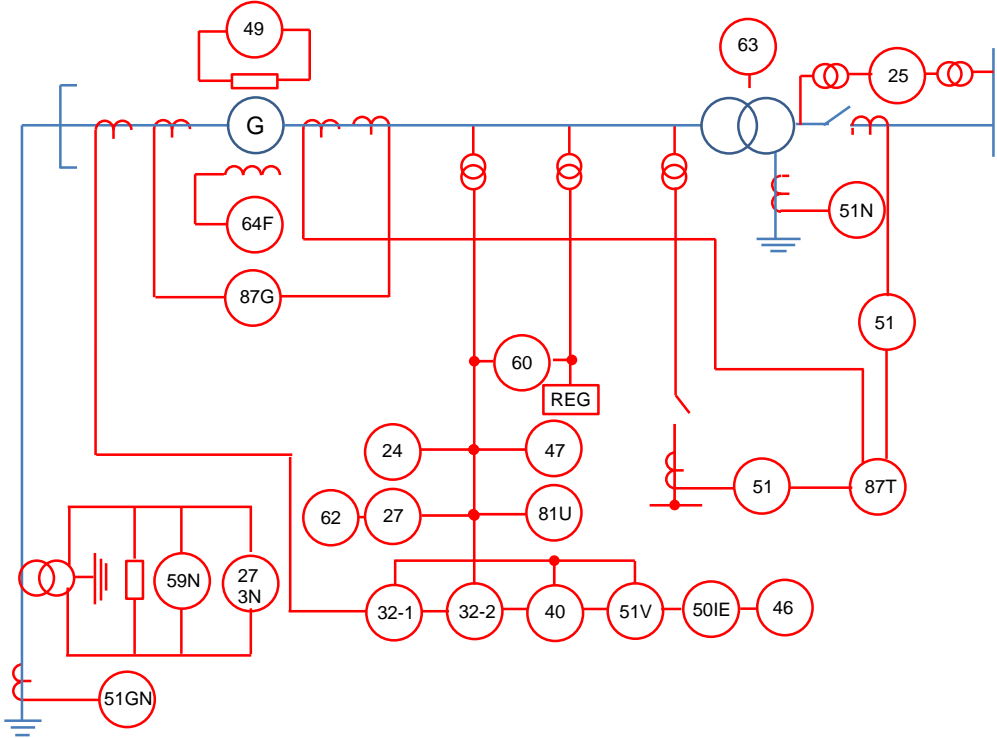

Figure 33. Extended protection (high resistance earthing)