

---

# Basic Tools for Electrical Protection and Short Circuit

Course No: E04-039

Credit: 4 PDH

---

Manuel Gooding, P.E.

---

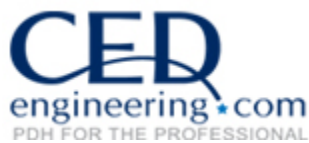

Continuing Education and Development, Inc.  
22 Stonewall Court  
Woodcliff Lake, NJ 07677

P: (877) 322-5800  
[info@cedengineering.com](mailto:info@cedengineering.com)

---

---

# *Basic Tools for Electrical Protection and Short Circuit*

---

# Basic Tools for Electrical Protection and Short Circuit

## Table of Contents

---

Introduction.....	3
Overview of Overcurrent Protection .....	3
Nature of overload and short circuits.....	4
Symmetrical Components .....	4
Vector “a” .....	6
Mathematical Properties of Vector “a” .....	6
Application of operator “a” Vector to Solution of an Unbalanced System.....	7
Impedance components .....	11
Transformers .....	13
Synchronous Machinery .....	13
Application of Symmetrical Components to protection system.....	15
Short Circuit Current Calculations .....	15
Per Unit System Calculations .....	17
Conversion to a new Base.....	19
Calculation tools .....	21
Examples.....	23
Short Circuit Calculation Procedures .....	28
Step 1 and 2 .....	28
Preparing Single line diagram – Location of Fault Points.....	28
Step 3 .....	29
Preparation of Impedance Diagram.....	29
Impedance Value Calculations.....	30
Impedance Diagrams .....	33
Calculations.....	34
Introduction to Protective Devices .....	36
Selection Considerations .....	36
Table of Figures .....	39

# Basic Tools for Electrical Protection and Short Circuit

## Introduction

---

This course deals with the description and solution of overcurrent and fault (short circuit) events in electrical circuits, mainly currents of high magnitude that occur in electrical systems and that affect system components.

The course will describe the basic physics of overcurrents and their effects in electrical components. Overcurrents of fault magnitude will be discussed including basic methodology for calculation of short circuits. Symmetrical Components will be presented for the engineer to have a basic knowledge of short circuit calculation basis.

Calculation of short circuit fault currents will have the following purposes:

- To evaluate fault currents to establish if the protective components and system components can withstand such large currents
- To obtain values of fault currents to set the short time of protective devices
- To provide information on the magnitude of the fault at several points of the system to set up proper protective device coordination

Reference to commercially available software will be made to permit the engineer who is interested, to further pursue this short circuit studies, initiating the search for modern study tools.

## Overview of Overcurrent Protection

---

To determine whether a current qualifies as overload current, we must understand the concept of overcurrent. Overcurrent is defined as the amount of current that, flowing in appropriately designed equipment, will result in loss, damage, or both. The current flowing in such a manner is more than the equipment design and of the correct design value.

The design value of current for equipment is termed as the rated value of current for such equipment.

The cause of an overcurrent is an anomaly in the proper function of the equipment, system or an accidental or unexpected connection event. This anomaly is an abnormal condition such as a locked rotor in a motor (motor overload); an unexpected event as an accidental contact

## Basic Tools for Electrical Protection and Short Circuit

with ground of an active phase of a feeder (short circuit to ground); or simply an internal electrical element failure, such as in an insulation failure in a transformer.

Overcurrent phenomena are complex events. When a circuit changes from a steady state condition to a completely different electrical state, the electrical components react in different ways. Resistors overheat, capacitors act as shorts and inductors oppose the change, acting almost as open circuits. As the change continues, the opposition to change produces oscillating waveforms that add to the complexity of the analysis of the event. Analysis of these changing conditions, its physics and mathematical interpretation, are all part of the tasks that an engineer must tackle in order to understand how to protect the circuits, and in many cases, the personnel who work around the electrical system.

### Nature of overload and short circuits

The study of the nature of overload and short circuit conditions will involve the following elements:

- Waveforms of short circuit currents
- Source of Short Circuit currents
- Methods for calculation of Short Circuits
- Setting of Protection devices
- Rating of electrical equipment

The above listed items will be addressed in the following parts of this course. Knowledge of supporting mathematical tools and vectors is important in the analysis of the mathematics of short circuit calculations and will be briefly reviewed below.

### Symmetrical Components

Analysis of an AC circuit that has a perfect sine wave system, such as a three-phase system with a  $120^\circ$  phase angle between phases and equal voltage magnitudes, is referred to as an analysis of a symmetrical AC system.

## Basic Tools for Electrical Protection and Short Circuit

When a short circuit or occurs, the waveforms produced in the electrical system are of much higher magnitude and would normally decrease with time. **Figure 1** below shows the shape of a typical short circuit wave.

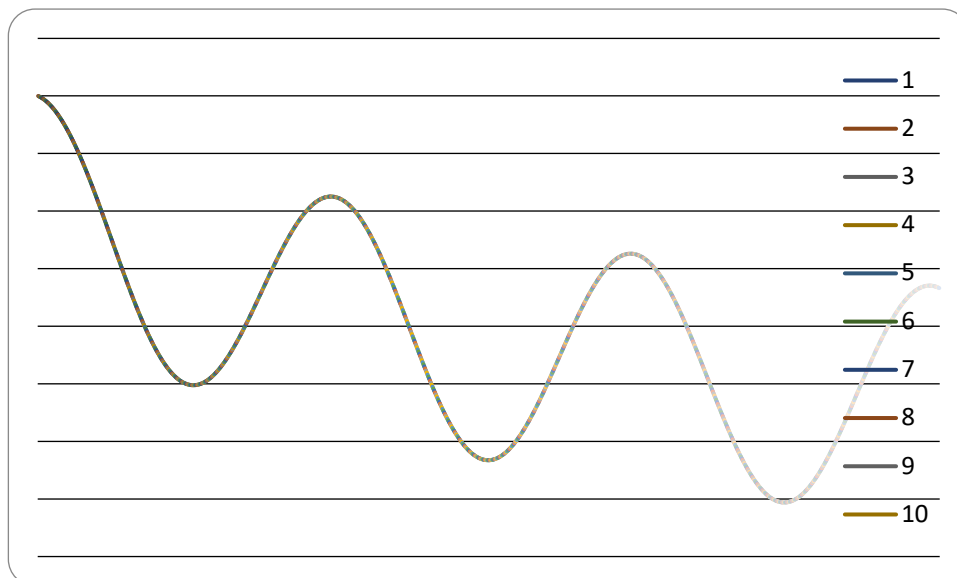

**Figure 1** – Typical Short Circuit waveform

The analysis of a wave, such as the one above, is done with the help of a method called Symmetrical Components originally presented by Dr. Charles L. Fortescue in his 1918 paper titled “Method of Symmetrical Coordinates Applied to the Solution of Polyphase Networks”.

The principle of this method applied, to an unbalanced system represented by three phase circuit vectors, is that this unbalanced system of vectors can be resolved into three sets of vectors. Each set has three vectors that are equal in magnitude and its vectors are either spaced  $120^\circ$  or zero.

Each set of the resulting vectors is called a symmetrical component of the original unbalanced set.

The name of symmetrical vectors is because the angles that separate a vector from the next, when taken in sequence, are equal.

When using this analysis, the engineer will can predict the behavior of a power system during an unbalanced event.

## Basic Tools for Electrical Protection and Short Circuit

### Vector “a”

---

The vector “a” is a unitary (magnitude = 1) vector that has unit length and has an angle of 120° in the counterclockwise direction. It can be written as

- $1\angle 120$
- $e^{j120}$
- $-\frac{1}{2} + j\frac{\sqrt{3}}{2}$

When a vector V is multiplied by vector “a” it only changes its rotation. Since the magnitude of “a” is 1 or unitary, the magnitude of vector V remains unchanged. See **Figure 2** below, where Vector V is shown in relation to vector aV.

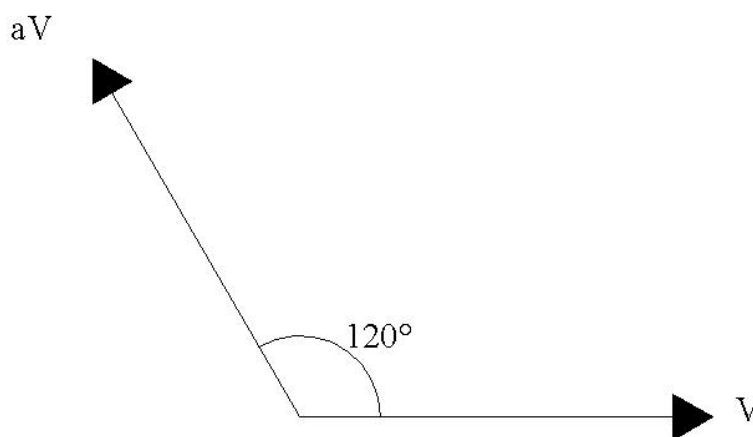

**Figure 2 – 120 degree separated vectors**

### Mathematical Properties of Vector “a”

---

We list below some of the most useful properties of vector “a”:

- $a = 1\angle 120 = -\frac{1}{2} + j\frac{\sqrt{3}}{2}$
- $a^2 = 1\angle 240$
- $a^4 = a$
- $a^5 = a^2$

The operator A can be used in matrix format, and it is:

## Basic Tools for Electrical Protection and Short Circuit

$$A = \begin{bmatrix} 1 & 1 & 1 \\ 1 & a^2 & a \\ 1 & a & a^2 \end{bmatrix}$$

### Application of operator “a” Vector to Solution of an Unbalanced System

In this application we have an unbalanced, three phase voltage system. It can be expressed by three vectors.

$V_a, V_b, V_c$

These vectors are shown below in Figure 3.

Applying the symmetrical component concepts, we can represent any three-vector system by three vectors systems that are equal in magnitude and separated by either  $120^\circ$  or zero.

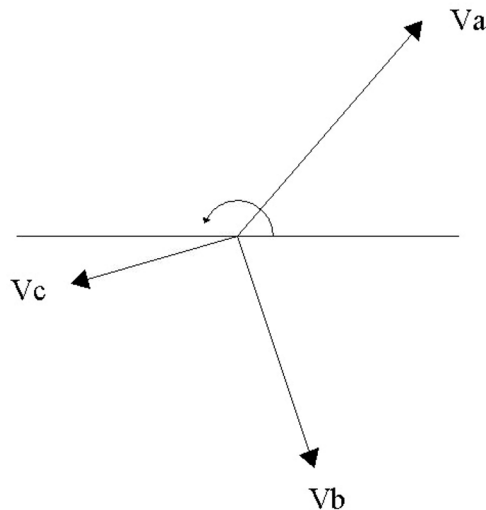

**Figure 3 – Unbalanced Vectors**

This system of vectors is also represented by the following symmetrical system equations in which  $V_0$ ,  $V_1$ , and  $V_2$  are the zero, positive and negative sequence symmetrical components of the vector system:



## Basic Tools for Electrical Protection and Short Circuit

### Equation 1

$$V_0 = \frac{1}{3} (V_a + V_b + V_c)$$

### Equation 2

$$V_1 = \frac{1}{3} (V_a + aV_b + a^2V_c)$$

### Equation 3

$$V_2 = \frac{1}{3} (V_a + a^2V_b + aV_c)$$

In determining the rotation, the original vectors  $V_a$ ,  $V_b$  and  $V_c$  rotate counterclockwise, which is defined as positive, indicating that the system is rotating in a positive sequence.

Equation 1 is called the zero-sequence vector system and its value is  $V_0 = V_{0a} = V_{0b} = V_{0c}$

Equation 2 represents the positive sequence components system. Vector  $V_a$  cuts the axis first on rotation, then  $aV_b$  120 degrees later and then  $a^2V_c$  240 degrees later. Since all cross the axis in the same way that the original three vectors, the system of vectors is rotating in a positive sequence.

Also note that:

- $V_a = V_{1a}$  is identified as the positive sequence component of  $V_a$
- $aV_b = V_{1b}$  is identified as the positive sequence component of  $V_b$
- $a^2V_c = V_{1c}$  is identified as the positive sequence component of  $V_c$

## Basic Tools for Electrical Protection and Short Circuit

See Figure 4 below.

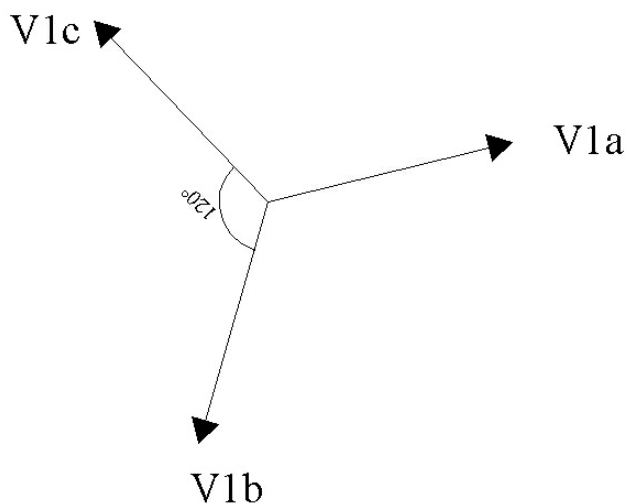

**Figure 4 – Positive sequence vectors**

Equation 3 represents the negative sequence components system. Vector  $V_a$  cuts the axis first on rotation, then  $aV_c$  120 degrees later, and then  $a^2V_b$  240 degrees later. Since all cross the axis in an a, c, b way they are rotating counterclockwise or in a negative sequence.

Also note that:

- $V_a = V_{2a}$  is identified as the negative sequence component of  $V_a$
- $aV_b = V_{2b}$  is identified as the negative sequence component of  $V_b$
- $a^2V_c = V_{2c}$  is identified as the negative sequence component of  $V_c$

Also, the unbalanced system vectors can be written as function of the symmetrical component vectors as follows:

### Equation 4

$$V_a = V_{a0} + V_{a1} + V_{a2} = V_0 + V_1 + V_2$$

## Basic Tools for Electrical Protection and Short Circuit

### Equation 5

$$V_b = V_{b0} + V_{b1} + V_{b2} = V_0 + a^2V_1 + aV_2$$

### Equation 6

$$V_c = V_{c0} + V_{c1} + V_{c2} = V_0 + aV_1 + a^2V_2$$

Another property of symmetrical components is that the above equations can be used to solve line to neutral voltages; however, the delta or line to line voltage vectors are in a closed triangle, hence, the zero-sequence vector component is zero. As you can see in the zero-sequence equation (Equation 1), the value of this component is the vectorial sum of the three phases or line to line voltage which by Kirchhoff voltage law is zero.

The symmetrical component resolution applied to currents follows similar analysis as above.

If the three phase currents are

$I_a$ ,  $I_b$ , and  $I_c$ , the symmetrical component equations are:

### Equation 7:

$$I_0 = I_{a0} = \frac{1}{3} (I_a + I_b + I_c)$$

### Equation 8:

$$I_1 = I_{a1} = \frac{1}{3} (I_a + aI_b + a^2I_c)$$

### Equation 9:

$$I_2 = I_{a2} = \frac{1}{3} (I_a + a^2I_b + aI_c)$$

Also:

### Equation 10

$$I_a = I_{a0} + I_{a1} + I_{a2} = I_0 + I_1 + I_2$$

## Basic Tools for Electrical Protection and Short Circuit

### Equation 11

$$I_b = I_{b0} + I_{b1} + I_{b2} = I_0 + a^2 I_1 + a I_2$$

### Equation 12

$$I_c = I_{c0} + I_{c1} + I_{c2} = I_0 + a I_1 + a^2 I_2$$

The Zero sequence current (of the line currents entering) in a delta system is also zero per Kirchhoff current law. Using the same reasoning, the zero sequence currents entering a star three phase system do not have a zero-sequence component.

Relationships between zero sequence components, and delta and wye components in three phase systems are compiled at the end of the course for reference.

### Impedance components

---

Sequence impedances are defined by  $Z_0$ ,  $Z_1$ , and  $Z_2$ , which are the zero, positive and negative sequence impedances of the system. These impedances are the same per phase, except in the case of a fault or unbalance.

Additionally, there are specific components for equipment such as transformers, motors, etc. Some of these components are presented in the following paragraphs.

As with other parameters, unbalanced impedances can be resolved into symmetrical components.

The equations that apply to a system of three unbalanced impedances such as in a wye configuration, each branch with an impedance of  $Z_a$ ,  $Z_b$ , and  $Z_c$  for phase a, b and c are as follows:

$$Z_0 = \frac{1}{3}(Z_a + Z_b + Z_c)$$

$$Z_1 = \frac{1}{3}(Z_a + aZ_b + a^2Z_c)$$

$$Z_2 = \frac{1}{3}(Z_a + a^2Z_b + aZ_c)$$

## Basic Tools for Electrical Protection and Short Circuit

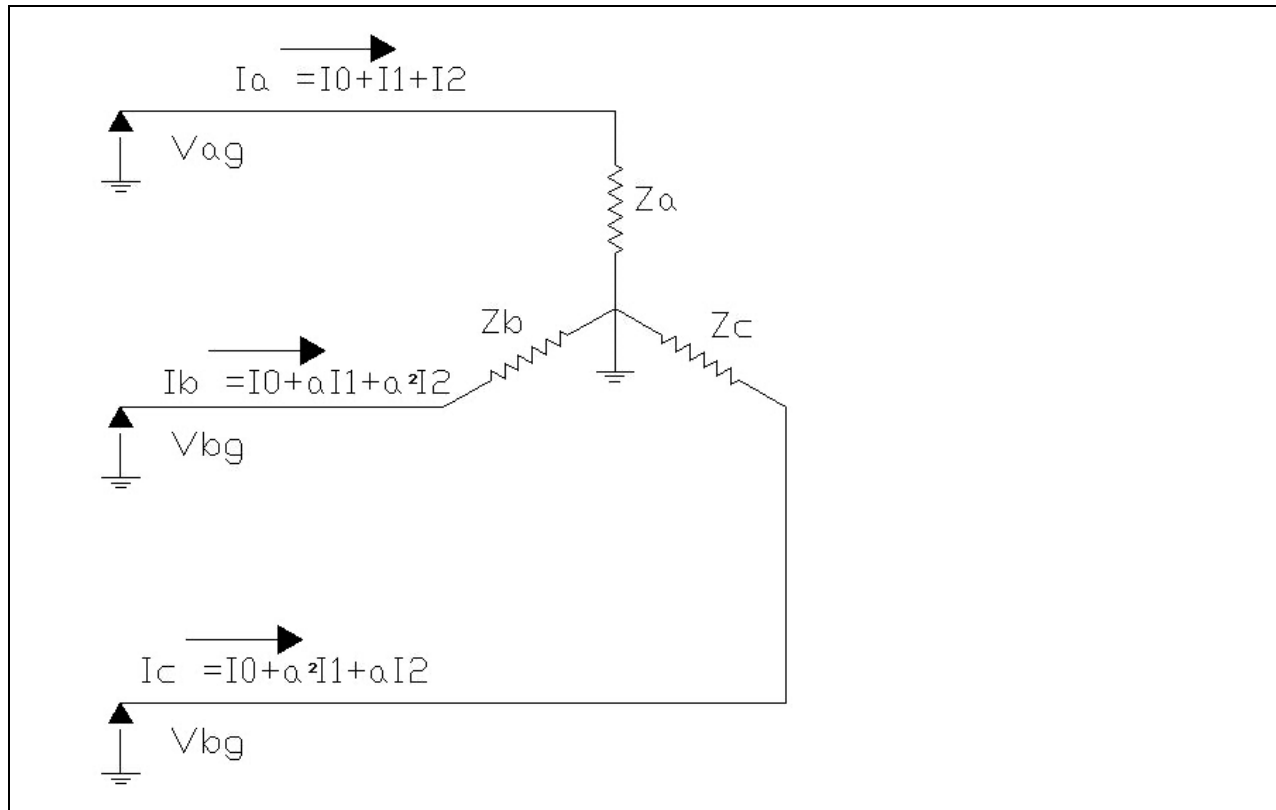

**Figure 5 Unbalance Impedances**

Applying the above symmetrical relations and Ohm's law we can write:

$$V_0 = \frac{1}{3}(V_{ag} + V_{bg} + V_{cg}) = I_0 Z_0 + I_1 Z_1 + I_2 Z_2$$

$$V_1 = \frac{1}{3}(V_{ag} + aV_{bg} + a^2V_{cg}) = I_0 Z_0 + aI_1 Z_1 + a^2I_2 Z_2$$

$$V_2 = \frac{1}{3}(V_{ag} + a^2V_{bg} + aV_{cg}) = I_0 Z_0 + a^2I_1 Z_1 + aI_2 Z_2$$

When the impedances are such that

$$Z_a = Z_b = Z_c$$

Then,

$$Z_1 = Z_2 = 0$$

## Basic Tools for Electrical Protection and Short Circuit

And,

$$Z_0 = Z_a$$

This condition is when the impedances are symmetrical, and the voltages will then be:

$$V_0 = I_0 Z_0$$

$$V_1 = I_1 Z_0$$

$$V_2 = I_2 Z_0$$

### Transformers

---

It is important to note that the positive sequence impedance of a transformer equals the leakage impedance. It is measured using a short-circuit test. The leakage impedance does not change, even if the phase sequence is altered from RYB to RBY. Therefore, the negative sequence impedance of transformer is the same as the positive sequence impedance.

The resistance is considered very small and is usually neglected. Positive and zero sequence reactances are normally equal for all transformers. However, zero reactances are different depending on the type of transformer.

Three phase, core type transformers exhibit zero sequence reactances that are equivalent to a closed delta winding due to its magnetic design.

For all other types of transformers, the zero-sequence reactance is infinite or equal to the other reactances.

Calculation of the zero reactances depends on the physical characteristics of the transformer. These operations are not in the scope of this short course but can be found in abundant available literature.

### Synchronous Machinery

---

Normally synchronous rotating equipment, such as generators and synchronous motors, specify three reactances:

## Basic Tools for Electrical Protection and Short Circuit

- Sub transient Reactance =  $X_d''$
- Transient Reactance =  $X_d'$
- Synchronous Reactance =  $X_d$

These reactances are normally used to calculate short circuits at various times as the short circuit progresses:

Reactance	Description	Application
Sub transient Reactance $X_d''$	Allows highest initial fault current value. Generator manufacturers supply two values: <ul style="list-style-type: none"> <li>• <math>X_{dv}''</math> – Rated voltage, Saturated, smaller magnitude</li> <li>• <math>X_{di}''</math> – Rated current, unsaturated, larger magnitude</li> <li>• Only reactance value assigned to induction motors and generator fault calculations</li> </ul>	Fault calculations: <ul style="list-style-type: none"> <li>• High speed relays</li> <li>• Normally <math>X_{dv}''</math> is used for a conservative estimate</li> </ul>
Transient Reactance $X_d'$	Next in magnitude, for a synchronous generator, it is the reactance value after about 0.1 s of the start of a fault	Stability calculations: Low speed relays
Synchronous Reactance $X_d$	Reactance value after steady state conditions	Sustained fault calculations

## Basic Tools for Electrical Protection and Short Circuit

### Application of Symmetrical Components to protection system

There are many protection relays that use the symmetrical component vectors to detect system faults. The following table indicates a few of these components:

Device	Application
Negative-sequence relay	This relay provides protection for large generators, as well as smaller generators in back up units, such as in peaking plants.
Positive sequence relay	Used by many relays in the industry reliably implemented in directional applications
Instrument transformer zero sequence quantity detection	Ground fault detection
HBC pilot wire relay	Positive sequence filter implementation to initiate breaker high speed tripping

### Short Circuit Current Calculations

Short-circuit calculations involves complex calculations, in order to simplify the calculations methods have been developed to obtain acceptable short circuit values that can be used in the proper assessment of the short circuit. This will permit the protection engineer to set the protective devices as well as evaluate the proper settings of electrical equipment.

The most elemental knowledge needed to calculate short circuit values is the well-known Ohms Law:

#### Equation 13

$$I = \frac{V}{Z}$$



## Basic Tools for Electrical Protection and Short Circuit

In which  $I$  is the value of the current,  $V$  the system voltage at the source, and  $Z$  the impedance. The impedance is measured from the point of the short circuit back to the rest of the system, including the generating equipment as well as the motors, which on short circuit conditions become short time generators, including the impedance of the source.

Impedance values used in this calculation are based on the proper equipment ratings.

Additional information needed include the maximum available short circuit from the sources, normally utility connections. The value used for impedance in the sources is the Sub transient Reactance  $X''$ .

The reason for using this value is that the short circuit ratings of distribution protective equipment are based on the maximum AC component current during the first cycle of the short circuit.

The basic Ohms Law equation for the source becomes:

### Equation 14

$$I = \frac{E}{X''}$$

For high voltage (above 600V) breakers, the ratings use asymmetrical current values based on ANSI Standard C37.5-1979. After 1964, ratings use ANSI Standard C37.010-1979 which is based on symmetrical current ratings.

The difference in the use of the Standards is that in the later Standard the short circuit contributions of large induction motors, alternating decay from generators closely connected to the network and the exponential decay of the DC component of the short-circuit have been taken into consideration. This introduces more accurate values to the short-circuit contributions available in a short-circuit event.

One of the purposes of calculations is to simplify the structure of the circuit to be used in the calculations. One of the areas is the reduction of the multiple sources. A simplification is to

## Basic Tools for Electrical Protection and Short Circuit

reduce all the circuit parameters to a per unit method. Use of the per unit method simplify short circuit systems that involve several voltage levels. Another simplification of the network is to reduce the network to single impedance. Once these simplifications are accomplished, the calculations can be done using Thevenin theorem.

### Per Unit System Calculations

The Per Unit system as well as the Percent System is used to express electrical magnitudes in a simplified way. One of the immediate advantages is that it allows the engineer to compare magnitudes in a common base, obtaining a better perspective of the system.

The Per Unit value is a ratio of a parameter such as voltage to a chosen base of the same parameter:

$$\text{PerUnit Voltage} = \frac{\text{Voltage}}{\text{Base Voltage}}$$

This could be used for any electrical parameter:

$$\text{PerUnit Value} = \frac{\text{Number}}{\text{Base Number}}$$

As an example, if we have a 480 V system and the voltage across an electronic device is 465V, we can use the per unit value to compare the value of the voltages.

If we chose 480 V as the base voltage, then:

$$\text{PerUnit Voltage} = \frac{465}{480} = 0.969$$

The per unit value of the voltage being evaluated is 0.969

## Basic Tools for Electrical Protection and Short Circuit

The selected base voltage is selected by convenience; sometimes it is the main bus voltage or the utility voltage.

We can use this system to compare conditions.

If we have a system measuring 13400 V and a 2300 V starting voltage in a motor, we can compare to a system that measures 12500V and has a 2100 V starting voltage at the motor:

Per unit of the first case:

$$\text{PerUnit Voltage} = \frac{2300}{13400} = 0.171$$

Per unit of the second case:

$$\text{PerUnit Voltage} = \frac{2100}{12500} = 0.168$$

The percent system is also practical for comparison. To obtain percent values, the per unit value is multiplied by 100.

$$\text{PerCent Value} = \frac{\text{Number}}{\text{Base Number}} (100)$$

A word of caution, if you are using these systems, it is very important to divide the percent value by 100 to obtain per unit values.

The per unit value is used for all the electrical parameters in a system.

The most common per unit values chosen as base are the Base KVA (Also known as base S) and the base Voltage. The other parameters can be derived from these two values.

The percent current would be derived using Ohms law:

$$S = KVA = \frac{VI}{1000}$$

## Basic Tools for Electrical Protection and Short Circuit

$$I = \frac{KVA}{V} (1000)$$

The base line current for a three-phase system is:

$$PerCent I = \frac{Base KVA (1000)}{\sqrt{3} (Base Voltage)}$$

Base impedance can be calculated as follows:

$$PerUnit Impedance = \frac{Base Voltage}{\sqrt{3} (Base Current)}$$

### Conversion to a new Base

---

When a per unit value of a parameter is expressed in a given KVA base sometimes its value in a different base is necessary.

As an example, if the value of a transformer per unit reactance is known in a per unit KVA base and its value in another KVA base is needed, the following expressions can be used: p.u.  
Ohms<sub>old</sub>

If the base voltages are the same for both systems:

$$PU Ohms = \frac{Actual Ohms}{Base Ohms}$$

$$\frac{PU Ohms_{old}}{PU Ohms_{new}} = \frac{Base Ohms_{new}}{Base Ohms_{old}}$$

## Basic Tools for Electrical Protection and Short Circuit

$$Base\ Ohms_{old} = \frac{(1000)Base\ KV^2}{Base\ KVA_{old}}$$

$$Base\ Ohms_{new} = \frac{(1000)Base\ KV^2}{Base\ KVA_{new}}$$

$$\frac{Base\ Ohms_{old}}{Base\ Ohms_{new}} = \frac{\frac{(1000)Base\ KV^2}{Base\ KVA_{old}}}{\frac{(1000)Base\ KV^2}{Base\ KVA_{new}}}$$

With the same base voltage :

$$\frac{Base\ Ohms_{old}}{Base\ Ohms_{new}} = \frac{Base\ KVA_{new}}{Base\ KVA_{old}}$$

### Equation 15

$$\frac{PU\ Ohms_{old}}{PU\ Ohms_{new}} = \frac{Base\ KVA_{old}}{Base\ KVA_{new}}$$

Equation 15 can be used when a reactance from a transformer, based on a different base as the one required is to be calculated.

As an example, if a 1000 KVA transformer with an impedance of 8% is to be converted to a 10000 KVA base, the following calculation can be done:

First convert the percent value of the reactance of PU:

$$X_{pu} = \frac{8}{100} = .08$$

$$\frac{PU\ Ohms_{old}}{PU\ Ohms_{new}} = \frac{Base\ KVA_{old}}{Base\ KVA_{new}}$$

## Basic Tools for Electrical Protection and Short Circuit

$$PU\ Ohms_{new} = PU\ Ohms_{old} \frac{Base\ KVA_{new}}{Base\ KVA_{old}}$$

Replacing values into the previous relation:

$$PU\ Ohms_{new} = 0.08 \frac{10000}{1000} = 0.8$$

### Calculation tools

---

One of the most important calculation tools that is required to perform short circuit calculations is the single line diagram. From this diagram, the impedance diagrams are prepared for calculation of short circuit currents at the required points.

The impedances in the impedance diagram are expressed in values of

- Per unit
- Percent
- Ohms per phase

Independently of the value used, the important fact is that all the impedances must be expressed in the same unit system: Either per unit, Percent or Ohms per phase.

Information to be aware:

- Transformers ( with impedances of more than 4% ) , rotating machines, reactors: Although their impedance has a resistance value, their reactance component is much larger, so it can be neglected
- Cables, buses, open wire lines: The resistance must be included in the value of the impedance
- If the value of reactance to resistance is more than 4 the short-circuit calculation will have an error of less than 3% if the resistance value is neglected. This is usually the case for systems above 600V
- Utility System: Expressed with a single reactance value that indicates the available short circuit. However, depending on the X/R ratio, the resistance should be also

## Basic Tools for Electrical Protection and Short Circuit

included. Remember that it could be neglected if X/R is less than 4, (normal utility value is 5 to 12). Value for the utility could also be given as:

- Reactance in Ohms per phase (or impedance) for a given voltage
- Three-phase available short circuit KVA
- Three-phase short circuit current at a given voltage
- Per cent or per unit reactance on a given base (KVA)

The following tables give approximate values to calculate the motor KVA for various conditions:

Equipment	Type	Specification	KVA
Motors	All	All	$\frac{(V_{rated} I_{rated})}{1000}$
Motor	Induction	>100 HP or less	Rated HP
Motor	Induction	<1000 HP	0.95 rated HP
Motor	Induction	$\geq 1000$ HP	0.9 rated HP
Motor	Synchronous	0.8 PF	Rated HP
Motor	Synchronous	1.0 PF	0.8 Rated HP

**Table 1**

## Basic Tools for Electrical Protection and Short Circuit

### Examples

#### Example 1

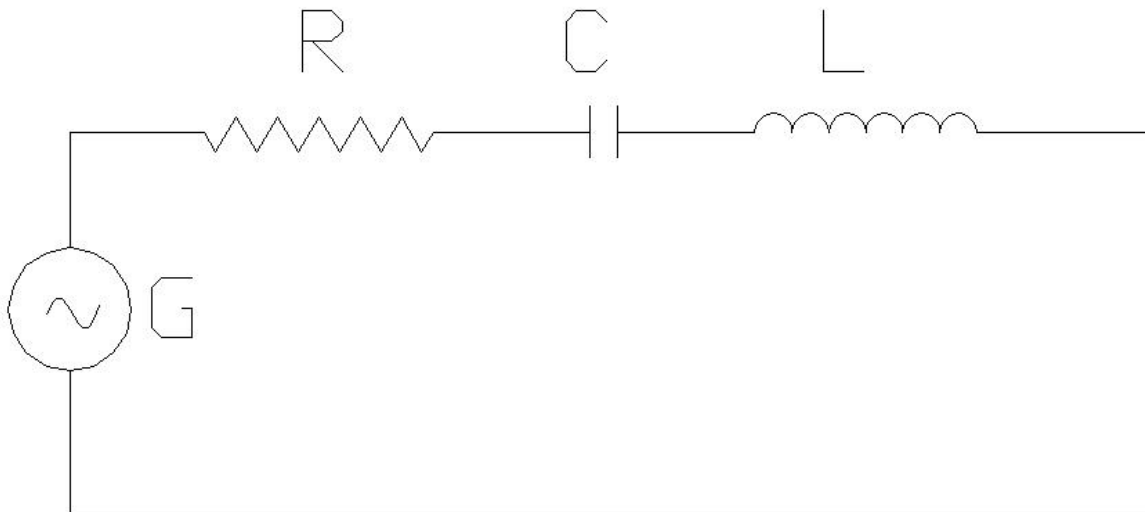

**Figure 6 RLC Circuit**

The values for the components are:

$$R = 4 \Omega,$$

$$L = 15.915 \text{ mHy}$$

$$C = 884.1 \mu\text{Fd}$$

$$V = 100\text{V}$$

1. Find  $Z$ ,  $I$ , and  $S$  Between the Generator "G" terminals.
2. Calculate  $Z$ ,  $R$  and  $X$  per-unit on bases of  $V_{\text{base}} = 100 \text{ V}$  and  $S_{\text{base}} = 1000 \text{ V}$ .

1) The  $Z$ ,  $I$  and  $S$  values are calculated below:

a) The values for  $X_L$  and  $X_C$  are calculated as follows:

$$\text{i) } X_L = 2\pi fL = 2\pi 60(15.915)10^{-3} = 6\Omega$$

$$\text{ii) } X_C = \frac{1}{2\pi fC} = \frac{1}{2\pi 60(0.0008841)} = 3\Omega$$

b) The impedance  $Z$  viewed from the generator terminal is:



## Basic Tools for Electrical Protection and Short Circuit

$$Z = 4 + j6 - j3 = 4 + j3 = 5 \angle 36.9$$

c) The current is calculated as follows:

$$I = \frac{V}{Z} = \frac{100}{5 \angle 36.9} = 20 \angle -36.9$$

d) Power then is:

$$S = V I^* = 100 \angle 0 (20 \angle -36.9)^* = 2000 \angle 36.9 = 1200 + j 1600$$

2) The per unit values are then:

$$a) \text{ Base Ohms} = \frac{(1000) \text{Base KV}^2}{\text{Base KVA}} = \frac{(1000)100^2}{1000} = 10000 \text{ ohms}$$

$$Z_{p.u.} = \frac{5}{10000} = 0.00005 \text{ ohm}$$

b) Per Unit value of the reactance and resistance is as follows:

$$Z = 4 + j3$$

$$Z_{p.u.} = \frac{Z}{Z_{base}} = \frac{4 + j3}{1000} = .004 + .003j$$

$$X_{p.u.} = 0.003$$

$$R_{p.u.} = 0.004$$

## Basic Tools for Electrical Protection and Short Circuit

### Example 2

In this example we are going to use a short circuit case.

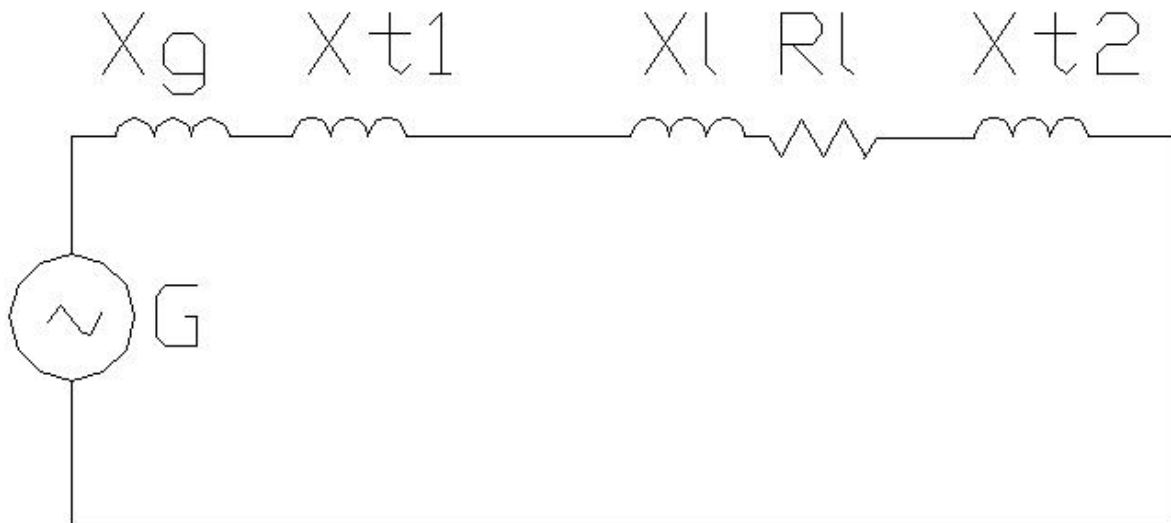

**Figure 7 Fault example**

The system parameters are as follows:

Description	Base MVA	Base Voltage	Impedance p.u.
Generator	100	26 KV	$j0.20$
Transformer 1 (GSU)	100	26/69 KV	$J0.10$
Transformer line	50	69 KV	$0.1 + j0.4$
Transformer 2	20	69/13.8	$J0.05$

The system is as indicated a generator connected to a Step-up Transformer. The power output from the secondary of the transformer is delivered to the substation load transformer via transmission line.

The problem postulates that there is a three-phase fault at the terminals of the secondary of the load transformer.

## Basic Tools for Electrical Protection and Short Circuit

The single one-line representation is given in figure 7 above. This single line assumes that the fault is a symmetrical event, thus the system can be represented with a single line as shown.

As you can see in the table above, the p.u. values are given in different base values, the first task is to make all these values uniform to the same base. The selected base is arbitrary, normally selected for system and calculation convenience. In this case, the selected base is 100 MVA.

We can use the relationships presented in the Section Conversion to a New Base above.

$$X_{g_{\text{new}}} = \frac{\text{MVA base old}}{\text{MVA base new}} X_{g_{\text{old}}}$$

$$X_{g_{\text{new}}} = \frac{100}{100} 0.20 = 0.20 \text{ Ohm}$$

$$X_{t1_{\text{new}}} = \frac{100}{100} 0.10 = 0.10 \text{ Ohm}$$

$$R_{t1_{\text{new}}} = \frac{50}{100} 0.10 = 0.05 \text{ Ohm}$$

$$X_{t1_{\text{new}}} = \frac{50}{100} 0.40 = 0.20 \text{ Ohm}$$

The circuit net impedance per unit is:

$$Z_{\text{total}} = 0.05 + j0.5$$

$$Z_{\text{p.u.}} = .502 \angle 84.3$$

The current can be calculated as follows:

## Basic Tools for Electrical Protection and Short Circuit

The per unit value of the voltage at the generator is 1 p.u. since the generator voltage is equal to the generator base voltage, the current is by Ohms law:

$$I_{p.u.} = \frac{1}{.502} = 1.99A \approx 2 A$$

To calculate the fault currents at different points in the circuit we first calculate the base current at those points.

The base current at the generator terminals is

$$I_{BASE} = \frac{Base\ MVA}{\sqrt{3}KVA} = \frac{100}{\sqrt{3}(26)} = 11.32\ KA$$

The current at the secondary of the GSU transformer is:

$$I_{BASE} = \frac{Base\ MVA}{\sqrt{3}KVA} = \frac{100}{\sqrt{3}(69)} = 6.95\ KA$$

The current at the secondary of the load transformer is:

$$I_{BASE} = \frac{Base\ MVA}{\sqrt{3}KVA} = \frac{100}{\sqrt{3}(13.8)} = 15.54\ KA$$

Multiplying these values per the P.U. current value we obtain the current fault values as:

$$I_{Fault\ g} = 6.95\ KA (2) = 22,645.4\ A$$

$$I_{Fault\ T2} = 15.54\ KA (2) = 31,083.41\ A$$

## Basic Tools for Electrical Protection and Short Circuit

### Short Circuit Calculation Procedures

---

The following procedures are recommended as guidance to perform Short Circuit calculations.

Step	Procedure
1	Prepare single line diagram
2	Indicate in the single line diagram location of short-circuit points
3	Prepare impedance diagram using single line diagram
4	Solve impedance network for each short circuit point separately

**Table 2**

### Step 1 and 2

#### Preparing Single line diagram – Location of Fault Points

---

This task requires that all the main system components be included. Each component must have its pertinent parameters indicated. These parameters include those specified above in

#### **Calculation Tools.**

The following is an example of an imaginary single line diagram indicating the parameters for the pertinent components as well as the points where the short-circuit calculations are to be performed.

## Basic Tools for Electrical Protection and Short Circuit

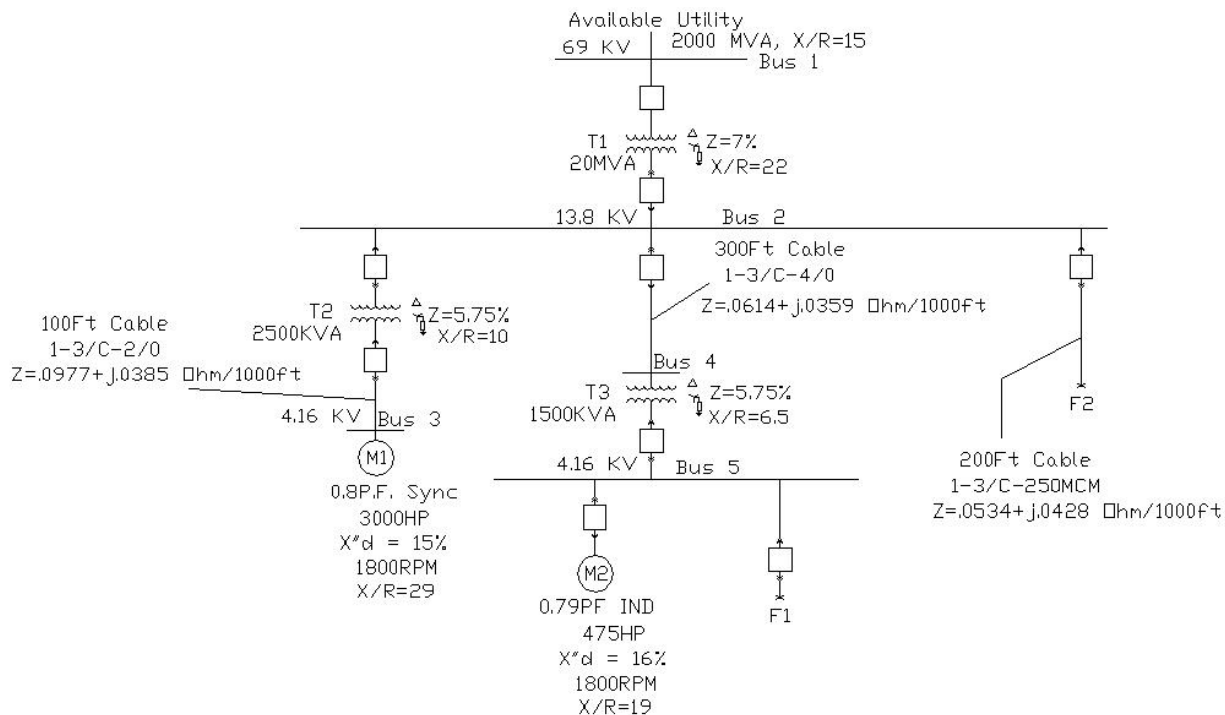

**Figure 8 - Typical Single Line Diagram**

### Step 3

#### Preparation of Impedance Diagram

The Impedance diagram is obtained from the Single line diagram. There are two diagrams of importance. The diagrams show in that one uses the first cycle impedances and the second reflects the 1.5 to 4 cycle impedance values.

There are two main activities to perform

- The first is to determine the impedance values for each of the two diagrams
- The second is to locate the impedances in the diagram drawing the values using the single line diagram as main referenced point

Part of the first activity is to use a practical system of values for the impedances. At this point we refer to the per unit system, applicable in our system because it has several voltage levels.

## Basic Tools for Electrical Protection and Short Circuit

### Impedance Value Calculations

---

First, we choose the base per unit value. In our case we choose 20MVA or 20,000 KVA.

We will present the calculations in the table below:

<b>Calculations Table</b>				
<b>Parameter</b>	<b>Data</b>		<b>First Cycle</b>	<b>1.5 to 4 cycles</b>
		<b>Per unit</b>	<b>1</b>	<b>1.5</b>
<b>Base KVA Utility</b>	20000			
Utility KVA	2000000			
Utility X/R	15			
<i>Z pu</i>		0.01		
<i>Angle in rad</i>		1.5		
<i>Degrees</i>		86.2		
<i>R</i>		0.0007		
<i>X</i>		0.01		
<b>Transformer T1</b>				

## Basic Tools for Electrical Protection and Short Circuit

Parameter	Data		First Cycle	1.5 to 4 cycles
KVA	20000			
Z %	7.0000			
X/R	22			
Z		0.07		
<i>Angle in radians</i>		1.5254		
R		0.003		
X		0.07		
<b>Transformer T2</b>				
KVA	2500			
Z %	5.75			
X/R	10			
Z		0.46		
<i>Angle in radians</i>		1.4711		
R		0.046		
X		0.46		
<b>Transformer T3</b>				
KVA	1500			
Z %	5.75			
X/R	6.5			
Z		0.77		
<i>Angle in radians</i>		1.4181		
R		0.117		
X		0.76		
<b>Cable 1</b>				
Voltage KV	4.16			
Length	100			
R per 200 ft	0.0977			
X per 100 ft	0.03895			
<i>R pu</i>		0.011291		
<i>X pu</i>		0.004501		
<b>Cable 2</b>				
Voltage KV	13.8			
Length	300			
R per 100 ft	0.0614			
X per 1000 ft	0.0359			



## Basic Tools for Electrical Protection and Short Circuit

Parameter	Data		First Cycle	1.5 to 4 cycles
$R_{pu}$		0.001934		
$X_{pu}$		0.001131		
<b>Motor 1</b>				
HP	3000			
$X''d \%$	15			
X/R	29			
PF	0.8			
KVA		2400		
R		0.043	0.043	0.065
$x''pu$		1.25		
Z			1.25	1.875
<b>Motor 2</b>				
HP	475			
$X''d \%$	16			
X/R	19			
PF	0.79			
KVA		375.25		
R		0.449	0.449	1.346
$x''pu$		8.527648 235		
Z			10.23317 788	25.58294 47
<b>Motor 3</b>				
HP	500			
$X''d \%$	16.7			
X/R	19.2			
PF	0.79			
KVA		395		
R		0.440	0.440	1.321
$x''pu$		8.455696 203		
Z			10.14683 544	25.36708 861

**Table 3 – Short-circuit Parameter Calculations**

# Basic Tools for Electrical Protection and Short Circuit

## Impedance Diagrams

Impedance diagrams are based on the important impedances at the moment of the fault. The one cycle and 1.5 cycle impedance values calculated in the impedance table above, give the value of the impedances that change value from the 1 cycle to 1.5 cycle events.

These diagrams are presented below and illustrate the method used to connect the impedances in the diagram.

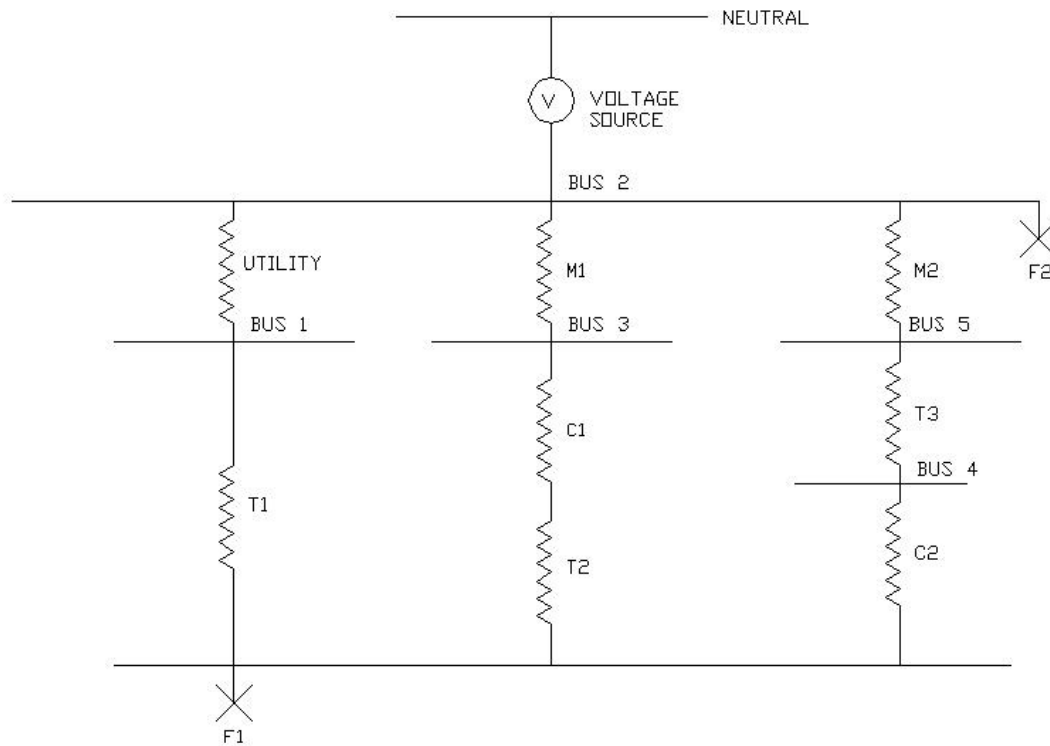

Figure 9 - Impedance diagram 1

## Basic Tools for Electrical Protection and Short Circuit

### Calculations

Next, we solve the impedance diagram for the 1 cycle fault at F1. The reader is encouraged to solve for 1.5 cycles. In order to solve for 1.5 cycles, the parameters for 1.5 replace the 1 cycle values.

The following tables show the calculations for the short circuit using the impedance diagram in Figure 9 - Impedance diagram 1.

<i>Current and Impedance values</i>		
<i>KVA<sub>B</sub></i>	<i>KV<sub>B</sub></i>	<i>I<sub>B</sub></i>
20000	13.8	836.7
20000	0.48	24056.3
20000	4.15	2782.4

**Table 4 - Per unit calculated values**

	<b>Branch</b>	<b>Values</b>	<b>R</b>	<b>X</b>	<b>Z</b>	<b>Degrees</b>
1	U <sub>t</sub> + T <sub>1</sub>	(0.0007 + j0.01) + (0.003 + j0.07)	0.0037	0.0799	0.0800	87.35
2	M <sub>1</sub> + C <sub>1</sub> + T <sub>2</sub>	(0.043 + j1.25) + (0.0113 + j0.0045) + (0.046 + j0.46)	0.1002	1.7122	1.7151	1.5124
3	M <sub>2</sub> + T <sub>3</sub> + C <sub>2</sub>	(0.449 + j10.23) + (0.117 + j0.76) + (0.117 + j0.76)	0.5673	10.9921	11.0067	1.5192
4	1 parallel with 2		0.00371	0.07634	0.076433	1.5223
5	4 parallel with 3	<b>Total impedance</b>	<b>0.00368</b>	<b>0.07582</b>	<b>0.0759</b>	<b>1.5222</b>
6	$I_{sc} = \frac{I_b}{Z_{total}} = \frac{836.7}{.0759} = 11,023.35 \text{ A}$					

**Table 5 - Impedance and short circuit calculations**

## Basic Tools for Electrical Protection and Short Circuit

The impedance value for this configuration at point 1 is calculated to be 11,023.35 A

Short-circuit currents are calculated to decide and evaluate the size of fuses, circuit breakers, and other protective devices. Each device is specified using various types of currents. The following are common current types used in specifying the protective device:

- interrupting duty
- momentary duty
- close and latch duty
- breaking duty

The methodology for calculating these currents is specified in ANSI standard application guides. These currents are used for evaluating fuses and circuit breakers. The nominal ratings for these devices are listed under ANSI standards.

From the European standards, the International Electrotechnical Commission (IEC) also defines calculating procedures for their rated protective devices.

Additionally, it is important to evaluate the capacity of various devices to sustain a fault event. For example, some devices, such as transformers, should be selected to withstand the available fault magnitude. Currents are related to the thermal capability of transformers. Also, during a fault, electromagnetic forces applied to the transformer produce mechanical stresses to the internal bracing of the transformer components. Both thermal and mechanical withstand capabilities must be taken into consideration when evaluating the adequacy of a transformer in the event of a fault.

Other components such as conductors and grid systems must be evaluated to determine if the short circuit produced thermal energy is adequately dissipated during the fault.

## Basic Tools for Electrical Protection and Short Circuit

### Introduction to Protective Devices

---

Faults in a power system are isolated by opening a device that interrupts the flow of current coming from the energy source. The isolation or protection device is located as close to the equipment where protection is desired.

At the beginning of the course, we indicated that we would present adjustment and setting of protective devices as well as the basic techniques of protective device selection, principles of operation and settings.

In order to do this, we will first briefly describe the most common protection devices and then present some techniques for setting these devices.

### Selection Considerations

---

When selecting protective devices, the device characteristics include the protective device selector.

These characteristics are normally described in a graphical form using a log-log coordinate system. The curves present on the abscissa (X-axis) current in Amperes In per unit in the following figure. The ordinate (Y-axis) represents time in seconds.

When a fault occurs, the device will trip if the current reaches a point between the minimum and maximum clearing times.

## Basic Tools for Electrical Protection and Short Circuit

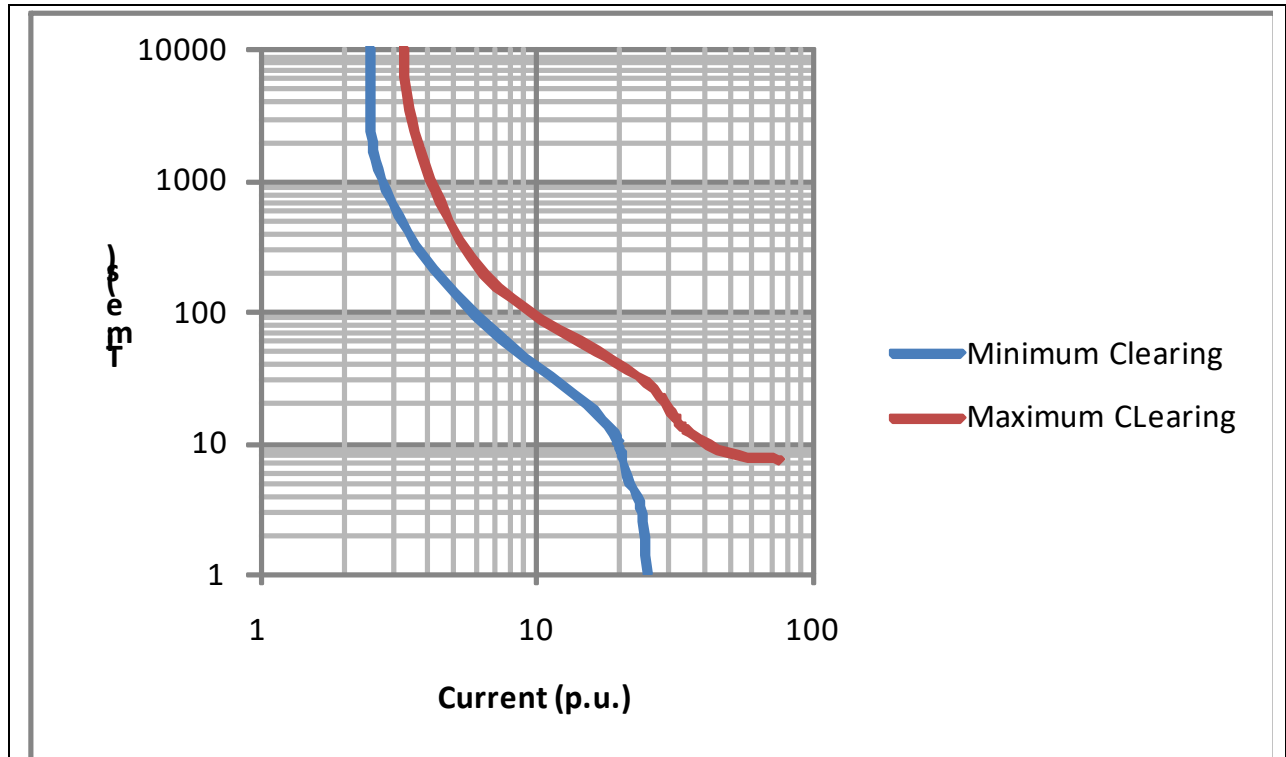

Figure 10 – Time –Current curve for a low voltage breaker.

## Basic Tools for Electrical Protection and Short Circuit

The protection engineer uses these curves to perform coordination between several protection devices located in the circuit. The main purpose of coordination is to isolate the fault area without interruption of service or power to the rest of the components of the system.

To perform coordination between protection devices, the curve of the device that trips first must be located to the left of the curve used by the next tripping device. That way the fault actuates the protection device that isolates the fault in the smallest area possible.

Following the above technique, you can accomplish a coordination task where the trip that is closer to the fault has to trip sooner than the one farther. The curves are used to select the trip point on the protective device. The trip point is defined by both the trip time and the magnitude of the fault at the base of the protective device. The engineer must select the appropriate curve to set the protective device for tripping.

One topic that is important to understand is that the NEC insists on selective coordination at very short time levels. This is basically accomplished by looking at the bottom of the curve (usually 0.1 second) and making sure that

1. The curves do not overlap
2. That if they overlap the devices are selectively coordinated by test (such as UL or the manufacturer)

Use of available quality software for both short circuit calculations and coordination is great help to the designer, however, the results must be reasoned and interpreted to make sure that individual and equipment protection is truly accomplished, including compliance with the safety codes such as the National Electrical Code, Fire (NFPA) codes, national and local codes. Signature by a Professional Engineer is a requirement in most of the cases.

## Basic Tools for Electrical Protection and Short Circuit

### Table of Figures

---

<b>Figure 1</b> – Typical Short Circuit waveform.....	5
Figure 2 – 120 degree separated vectors .....	6
Figure 3 – Unbalanced Vectors .....	7
Figure 4 – Positive sequence vectros.....	9
Figure 5 Unbalance Impedances.....	12
Figure 6 RLC Circuit.....	23
Figure 7 Fault example .....	25
Figure 8 - Typical Single Line Diagram .....	29
Figure 9 - Impedance diagram 1 .....	33
Figure 10 – Time –Current curve for a low voltage breaker.....	37