Capacitance

Course No: E04-004

Credit: 4 PDH

A. Bhatia



Continuing Education and Development, Inc.
22 Stonewall Court
Woodcliff Lake, NJ 07677

P: (877) 322-5800
info@cedengineering.com

CHAPTER 3

CAPACITANCE

LEARNING OBJECTIVES

Upon completion of this chapter you will be able to:

1. Define the terms "capacitor" and "capacitance."
2. State four characteristics of electrostatic lines of force.
3. State the effect that an electrostatic field has on a charged particle.
4. State the basic parts of a capacitor.
5. Define the term "farad".
6. State the mathematical relationship between a farad, a microfarad, and a picofarad.
7. State three factors that affect the value of capacitance.
8. Given the dielectric constant and the area of and the distance between the plates of a capacitor, solve for capacitance.
9. State two types of power losses associated with capacitors.
10. Define the term "working voltage" of a capacitor, and compute the working voltage of a capacitor.
11. State what happens to the electrons in a capacitor when the capacitor is charging and when it is discharging.
12. State the relationship between voltage and time in an RC circuit when the circuit is charging and discharging.
13. State the relationship between the voltage drop across a resistor and the source voltage in an RC circuit.
14. Given the component values of an RC circuit, compute the RC time constant.
15. Use the universal time constant chart to determine the value of an unknown capacitor in an RC circuit.
16. Calculate the value of total capacitance in a circuit containing capacitors of known value in series.
17. Calculate the value of total capacitance in a circuit containing capacitors of known value in parallel.
18. State the difference between different types of capacitors.
19. Determine the electrical values of capacitors using the color code.

CAPACITANCE

In the previous chapter you learned that inductance is the property of a coil that causes electrical energy to be stored in a magnetic field about the coil. The energy is stored in such a way as to oppose any change in current. CAPACITANCE is similar to inductance because it also causes a storage of energy. A CAPACITOR is a device that stores electrical energy in an ELECTROSTATIC FIELD. The energy is stored in such a way as to oppose any change in voltage. Just how capacitance opposes a change in voltage is explained later in this chapter. However, it is first necessary to explain the principles of an electrostatic field as it is applied to capacitance.

Q1. Define the terms "capacitor" and "capacitance."

THE ELECTROSTATIC FIELD

You previously learned that opposite electrical charges attract each other while like electrical charges repel each other. The reason for this is the existence of an electrostatic field. Any charged particle is surrounded by invisible lines of force, called electrostatic lines of force. These lines of force have some interesting characteristics:

- They are polarized from positive to negative.
- They radiate from a charged particle in straight lines and do not form closed loops.
- They have the ability to pass through any known material.
- They have the ability to distort the orbits of tightly bound electrons.

Examine figure 3-1. This figure represents two unlike charges surrounded by their electrostatic field. Because an electrostatic field is polarized positive to negative, arrows are shown radiating away from the positive charge and toward the negative charge. Stated another way, the field from the positive charge is pushing, while the field from the negative charge is pulling. The effect of the field is to push and pull the unlike charges together.

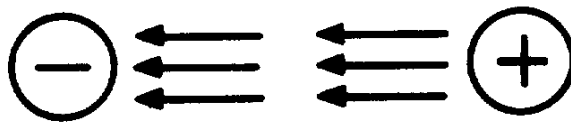

Figure 3-1.—Electrostatic field attracts two unlike charged particles.

In figure 3-2, two like charges are shown with their surrounding electrostatic field. The effect of the electrostatic field is to push the charges apart.

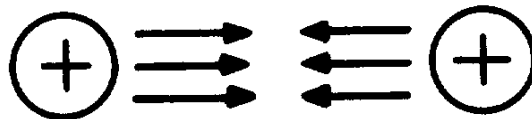

Figure 3-2.—Electrostatic field repels two like charged particles.

If two unlike charges are placed on opposite sides of an atom whose outermost electrons cannot escape their orbits, the orbits of the electrons are distorted as shown in figure 3-3. Figure 3-3(A) shows the normal orbit. Part (B) of the figure shows the same orbit in the presence of charged particles. Since the electron is a negative charge, the positive charge attracts the electrons, pulling the electrons closer to the positive charge. The negative charge repels the electrons, pushing them further from the negative charge. It is this ability of an electrostatic field to attract and to repel charges that allows the capacitor to store energy.

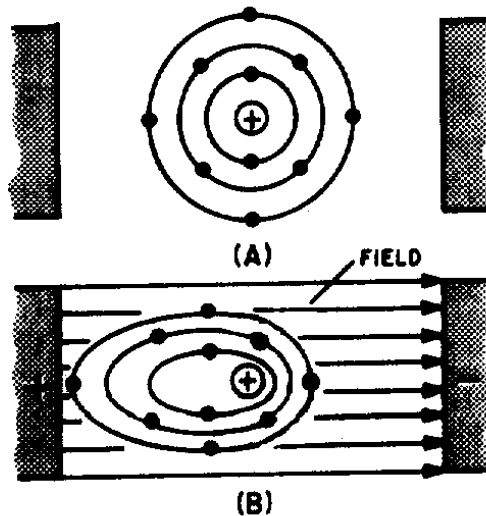

Figure 3-3.—Distortion of electron orbital paths due to electrostatic force.

- Q2. State four characteristics of electrostatic lines of force.
- Q3. An electron moves into the electrostatic field between a positive charge and a negative charge. Toward which charge will the electron move?

THE SIMPLE CAPACITOR

A simple capacitor consists of two metal plates separated by an insulating material called a dielectric, as illustrated in figure 3-4. Note that one plate is connected to the positive terminal of a battery; the other plate is connected through a closed switch (S1) to the negative terminal of the battery. Remember, an insulator is a material whose electrons cannot easily escape their orbits. Due to the battery voltage, plate A is charged positively and plate B is charged negatively. (How this happens is explained later in this chapter.) Thus an electrostatic field is set up between the positive and negative plates. The electrons on the negative plate (plate B) are attracted to the positive charges on the positive plate (plate A).

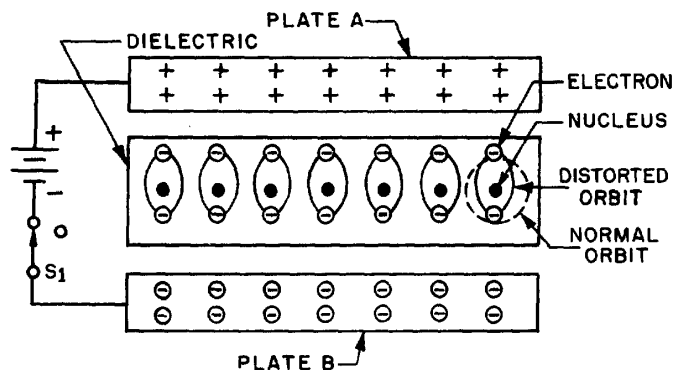

Figure 3-4.—Distortion of electron orbits in a dielectric.

Notice that the orbits of the electrons in the dielectric material are distorted by the electrostatic field. The distortion occurs because the electrons in the dielectric are attracted to the top plate while being repelled from the bottom plate. When switch S1 is opened, the battery is removed from the circuit and the charge is retained by the capacitor. This occurs because the dielectric material is an insulator, and the electrons in the bottom plate (negative charge) have no path to reach the top plate (positive charge). The distorted orbits of the atoms of the dielectric plus the electrostatic force of attraction between the two plates hold the positive and negative charges in their original position. Thus, the energy which came from the battery is now stored in the electrostatic field of the capacitor. Two slightly different symbols for representing a capacitor are shown in figure 3-5. Notice that each symbol is composed of two plates separated by a space that represents the dielectric. The curved plate in (B) of the figure indicates the plate should be connected to a negative polarity.

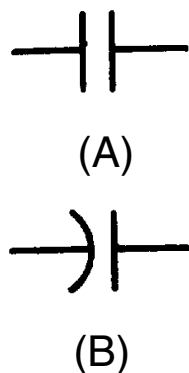

Figure 3-5.—Circuit symbols for capacitors.

Q4. What are the basic parts of a capacitor?

THE FARAD

Capacitance is measured in units called FARADS. A one-farad capacitor stores one coulomb (a unit of charge (Q) equal to 6.28×10^{18} electrons) of charge when a potential of 1 volt is applied across the terminals of the capacitor. This can be expressed by the formula:

$$C(\text{farads}) = \frac{Q(\text{coulombs})}{E(\text{volts})}$$

The farad is a very large unit of measurement of capacitance. For convenience, the microfarad (abbreviated μF) or the picofarad (abbreviated pF) is used. One (1.0) microfarad is equal to 0.000001 farad or 1×10^{-6} farad, and 1.0 picofarad is equal to 0.000000000001 farad or 1.0×10^{-12} farad. Capacitance is a physical property of the capacitor and does not depend on circuit characteristics of voltage, current, and resistance. A given capacitor always has the same value of capacitance (farads) in one circuit as in any other circuit in which it is connected.

Q5. Define the term "farad."

Q6. What is the mathematical relationship between a farad, a microfarad, and a picofarad.

FACTORS AFFECTING THE VALUE OF CAPACITANCE

The value of capacitance of a capacitor depends on three factors:

- The area of the plates.
- The distance between the plates.
- The dielectric constant of the material between the plates.

PLATE AREA affects the value of capacitance in the same manner that the size of a container affects the amount of water that can be held by the container. A capacitor with the large plate area can store more charges than a capacitor with a small plate area. Simply stated, "the larger the plate area, the larger the capacitance".

The second factor affecting capacitance is the DISTANCE BETWEEN THE PLATES. Electrostatic lines of force are strongest when the charged particles that create them are close together. When the charged particles are moved further apart, the lines of force weaken, and the ability to store a charge decreases.

The third factor affecting capacitance is the DIELECTRIC CONSTANT of the insulating material between the plates of a capacitor. The various insulating materials used as the dielectric in a capacitor differ in their ability to respond to (pass) electrostatic lines of force. A dielectric material, or insulator, is rated as to its ability to respond to electrostatic lines of force in terms of a figure called the DIELECTRIC CONSTANT. A dielectric material with a high dielectric constant is a better insulator than a dielectric material with a low dielectric constant. Dielectric constants for some common materials are given in the following list:

Material	Constant
Vacuum	1.0000
Air	1.0006
Paraffin paper	3.5
Glass	5 to 10
Mica	3 to 6
Rubber	2.5 to 35
Wood	2.5 to 8
Glycerine (15°C)	56
Petroleum	2
Pure water	81

Notice the dielectric constant for a vacuum. Since a vacuum is the standard of reference, it is assigned a constant of one. The dielectric constants of all materials are compared to that of a vacuum. Since the dielectric constant of air has been determined to be approximately the same as that of a vacuum, the dielectric constant of AIR is also considered to be equal to one.

The formula used to compute the value of capacitance is:

$$C = 0.2249 \left(\frac{KA}{d} \right)$$

Where C = capacitance in picofarads

A = area of one plate, in square inches

d = distance between the plates, in inches

K = dielectric constant of the insulating material

0.2249 = a constant resulting from conversion from Metric to English units.

Example: Find the capacitance of a parallel plate capacitor with paraffin paper as the dielectric.

Given: $K = 3.5$
 $d = 0.05$ inch
 $A = 12$ square inches

Solution: $C = 0.2249 \left(\frac{KA}{d} \right)$
 $C = 0.2249 \left(\frac{3.5 \times 12}{0.05} \right)$
 $C = 189$ picofarads

By examining the above formula you can see that capacitance varies directly as the dielectric constant and the area of the capacitor plates, and inversely as the distance between the plates.

- Q7. State three factors that affect the capacitance of a capacitor.*
- Q8. A parallel plate capacitor has the following values: $K = 81$, $d = .025$ inches, $A = 6$ square inches. What is the capacitance of the capacitor?*

VOLTAGE RATING OF CAPACITORS

In selecting or substituting a capacitor for use, consideration must be given to (1) the value of capacitance desired and (2) the amount of voltage to be applied across the capacitor. If the voltage applied across the capacitor is too great, the dielectric will break down and arcing will occur between the capacitor plates. When this happens the capacitor becomes a short-circuit and the flow of direct current through it can cause damage to other electronic parts. Each capacitor has a voltage rating (a working voltage) that should not be exceeded.

The working voltage of the capacitor is the maximum voltage that can be steadily applied without danger of breaking down the dielectric. The working voltage depends on the type of material used as the dielectric and on the thickness of the dielectric. (A high-voltage capacitor that has a thick dielectric must have a relatively large plate area in order to have the same capacitance as a similar low-voltage capacitor having a thin dielectric.) The working voltage also depends on the applied frequency because the losses, and the resultant heating effect, increase as the frequency increases.

A capacitor with a voltage rating of 500 volts dc cannot be safely subjected to an alternating voltage or a pulsating direct voltage having an effective value of 500 volts. Since an alternating voltage of 500 volts (rms) has a peak value of 707 volts, a capacitor to which it is applied should have a working voltage of at least 750 volts. In practice, a capacitor should be selected so that its working voltage is at least 50 percent greater than the highest effective voltage to be applied to it.

CAPACITOR LOSSES

Power loss in a capacitor may be attributed to dielectric hysteresis and dielectric leakage. Dielectric hysteresis may be defined as an effect in a dielectric material similar to the hysteresis found in a magnetic material. It is the result of changes in orientation of electron orbits in the dielectric because of the rapid reversals of the polarity of the line voltage. The amount of power loss due to dielectric hysteresis depends upon the type of dielectric used. A vacuum dielectric has the smallest power loss.

Dielectric leakage occurs in a capacitor as the result of LEAKAGE CURRENT through the dielectric. Normally it is assumed that the dielectric will effectively prevent the flow of current through the capacitor. Although the resistance of the dielectric is extremely high, a minute amount of current does flow. Ordinarily this current is so small that for all practical purposes it is ignored. However, if the leakage through the dielectric is abnormally high, there will be a rapid loss of charge and an overheating of the capacitor.

The power loss of a capacitor is determined by loss in the dielectric. If the loss is negligible and the capacitor returns the total charge to the circuit, it is considered to be a perfect capacitor with a power loss of zero.

Q9. Name two types of power losses associated with a capacitor.

Q10.

a. Define the term "working voltage" of a capacitor.

b. What should be the working voltage of a capacitor in a circuit that is operating at 600 volts?

CHARGING AND DISCHARGING A CAPACITOR

CHARGING

In order to better understand the action of a capacitor in conjunction with other components, the charge and discharge actions of a purely capacitive circuit are analyzed first. For ease of explanation the capacitor and voltage source shown in figure 3-6 are assumed to be perfect (no internal resistance), although this is impossible in practice.

In figure 3-6(A), an uncharged capacitor is shown connected to a four-position switch. With the switch in position 1 the circuit is open and no voltage is applied to the capacitor. Initially each plate of the capacitor is a neutral body and until a difference of potential is impressed across the capacitor, no electrostatic field can exist between the plates.

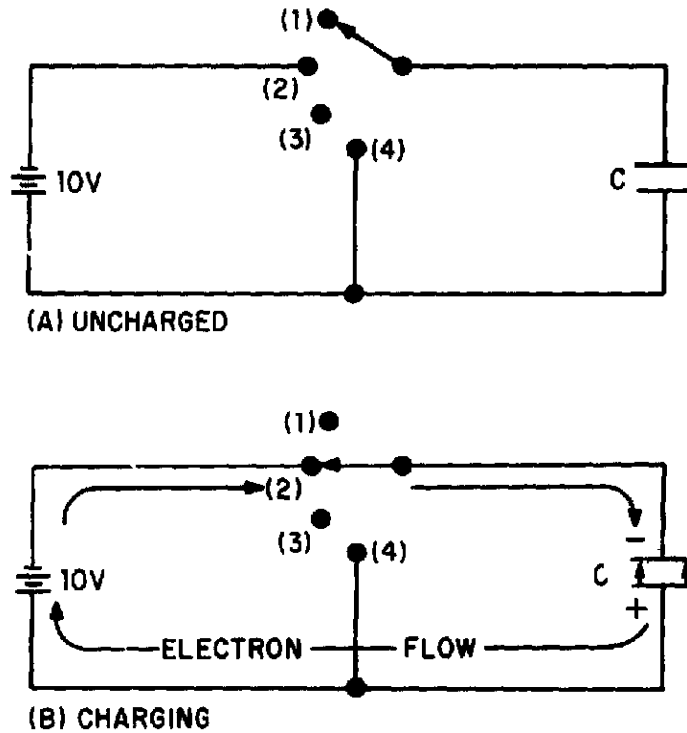

Figure 3-6.—Charging a capacitor.

To CHARGE the capacitor, the switch must be thrown to position 2, which places the capacitor across the terminals of the battery. Under the assumed perfect conditions, the capacitor would reach full charge instantaneously. However, the charging action is spread out over a period of time in the following discussion so that a step-by-step analysis can be made.

At the instant the switch is thrown to position 2 (fig. 3-6(B)), a displacement of electrons occurs simultaneously in all parts of the circuit. This electron displacement is directed away from the negative terminal and toward the positive terminal of the source (the battery). A brief surge of current will flow as the capacitor charges.

If it were possible to analyze the motion of the individual electrons in this surge of charging current, the following action would be observed. See figure 3-7.

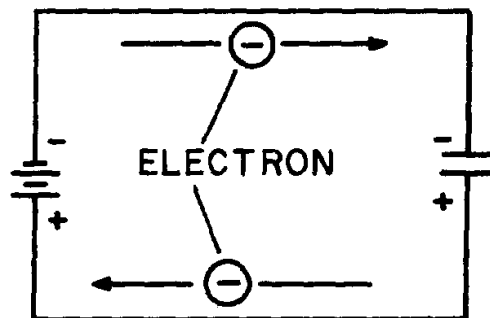

Figure 3-7.—Electron motion during charge.

At the instant the switch is closed, the positive terminal of the battery extracts an electron from the bottom conductor. The negative terminal of the battery forces an electron into the top conductor. At this same instant an electron is forced into the top plate of the capacitor and another is pulled from the bottom plate. Thus, in every part of the circuit a clockwise DISPLACEMENT of electrons occurs simultaneously.

As electrons accumulate on the top plate of the capacitor and others depart from the bottom plate, a difference of potential develops across the capacitor. Each electron forced onto the top plate makes that plate more negative, while each electron removed from the bottom causes the bottom plate to become more positive. Notice that the polarity of the voltage which builds up across the capacitor is such as to oppose the source voltage. The source voltage (emf) forces current around the circuit of figure 3-7 in a clockwise direction. The emf developed across the capacitor, however, has a tendency to force the current in a counterclockwise direction, opposing the source emf. As the capacitor continues to charge, the voltage across the capacitor rises until it is equal to the source voltage. Once the capacitor voltage equals the source voltage, the two voltages balance one another and current ceases to flow in the circuit.

In studying the charging process of a capacitor, you must be aware that NO current flows THROUGH the capacitor. The material between the plates of the capacitor must be an insulator. However, to an observer stationed at the source or along one of the circuit conductors, the action has all the appearances of a true flow of current, even though the insulating material between the plates of the capacitor prevents the current from having a complete path. The current which appears to flow through a capacitor is called DISPLACEMENT CURRENT.

When a capacitor is fully charged and the source voltage is equaled by the counter electromotive force (cemf) across the capacitor, the electrostatic field between the plates of the capacitor is maximum. (Look again at figure 3-4.) Since the electrostatic field is maximum the energy stored in the dielectric is also maximum.

If the switch is now opened as shown in figure 3-8(A), the electrons on the upper plate are isolated. The electrons on the top plate are attracted to the charged bottom plate. Because the dielectric is an insulator, the electrons can not cross the dielectric to the bottom plate. The charges on both plates will be effectively trapped by the electrostatic field and the capacitor will remain charged indefinitely. You should note at this point that the insulating dielectric material in a practical capacitor is not perfect and small leakage current will flow through the dielectric. This current will eventually dissipate the charge. However, a high quality capacitor may hold its charge for a month or more.

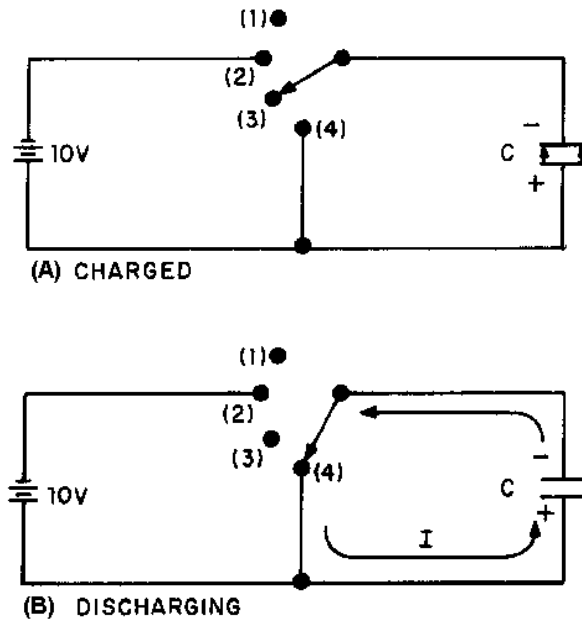

Figure 3-8.—Discharging a capacitor.

To review briefly, when a capacitor is connected across a voltage source, a surge of charging current flows. This charging current develops a cemf across the capacitor which opposes the applied voltage. When the capacitor is fully charged, the cemf is equal to the applied voltage and charging current ceases. At full charge, the electrostatic field between the plates is at maximum intensity and the energy stored in the dielectric is maximum. If the charged capacitor is disconnected from the source, the charge will be retained for some period of time. The length of time the charge is retained depends on the amount of leakage current present. Since electrical energy is stored in the capacitor, a charged capacitor can act as a source emf.

DISCHARGING

To DISCHARGE a capacitor, the charges on the two plates must be neutralized. This is accomplished by providing a conducting path between the two plates as shown in figure 3-8(B). With the switch in position (4) the excess electrons on the negative plate can flow to the positive plate and neutralize its charge. When the capacitor is discharged, the distorted orbits of the electrons in the dielectric return to their normal positions and the stored energy is returned to the circuit. It is important for you to note that a capacitor does not consume power. The energy the capacitor draws from the source is recovered when the capacitor is discharged.

Q11. State what happens to the electrons in a capacitor circuit when (a) the capacitor is charging and (b) the capacitor is discharging.

CHARGE AND DISCHARGE OF AN RC SERIES CIRCUIT

Ohm's law states that the voltage across a resistance is equal to the current through the resistance times the value of the resistance. This means that a voltage is developed across a resistance ONLY WHEN CURRENT FLOWS through the resistance.

A capacitor is capable of storing or holding a charge of electrons. When uncharged, both plates of the capacitor contain essentially the same number of free electrons. When charged, one plate contains more free electrons than the other plate. The difference in the number of electrons is a measure of the charge on the capacitor. The accumulation of this charge builds up a voltage across the terminals of the capacitor, and the charge continues to increase until this voltage equals the applied voltage. The charge in a capacitor is related to the capacitance and voltage as follows:

$$Q = CE,$$

in which Q is the charge in coulombs, C the capacitance in farads, and E the emf across the capacitor in volts.

CHARGE CYCLE

A voltage divider containing resistance and capacitance is connected in a circuit by means of a switch, as shown at the top of figure 3-9. Such a series arrangement is called an RC series circuit.

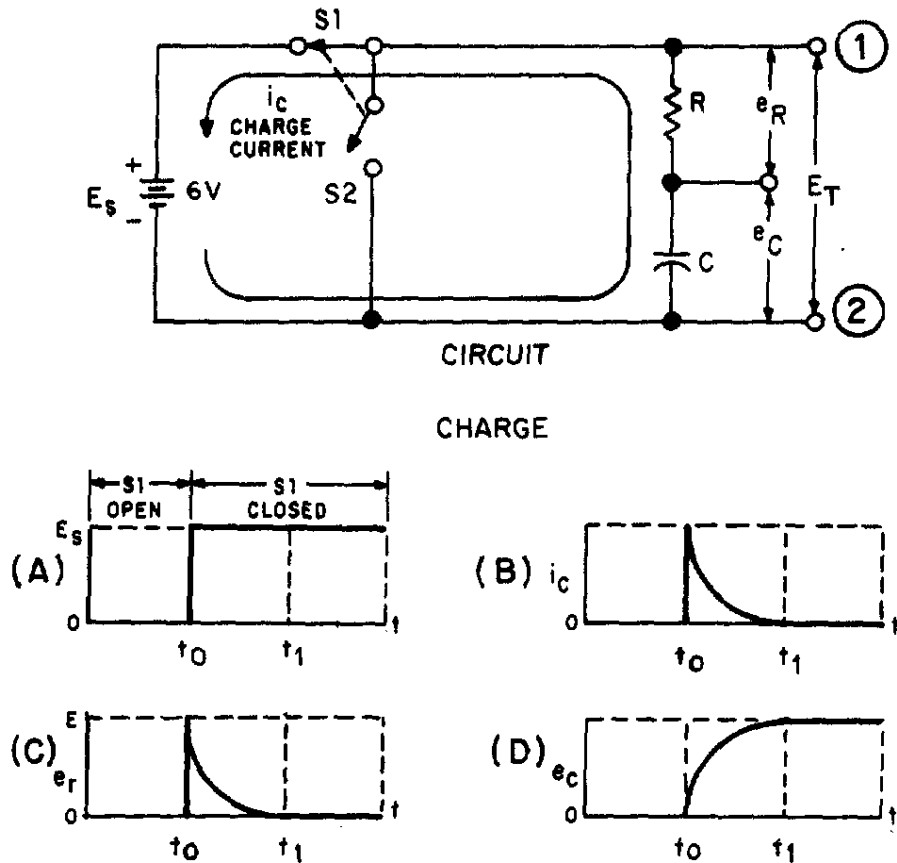

Figure 3-9.—Charge of an RC series circuit.

In explaining the charge and discharge cycles of an RC series circuit, the time interval from time t_0 (time zero, when the switch is first closed) to time t_1 (time one, when the capacitor reaches full charge or discharge potential) will be used. (Note that switches S_1 and S_2 move at the same time and can never both be closed at the same time.)







When switch S1 of the circuit in figure 3-9 is closed at t_0 , the source voltage (E_s) is instantly felt across the entire circuit. Graph (A) of the figure shows an instantaneous rise at time t_0 from zero to source voltage ($E_s = 6$ volts). The total voltage can be measured across the circuit between points 1 and 2. Now look at graph (B) which represents the charging current in the capacitor (i_c). At time t_0 , charging current is MAXIMUM. As time elapses toward time t_1 , there is a continuous decrease in current flowing into the capacitor. The decreasing flow is caused by the voltage buildup across the capacitor. At time t_1 , current flowing in the capacitor stops. At this time, the capacitor has reached full charge and has stored maximum energy in its electrostatic field. Graph (C) represents the voltage drop (e) across the resistor (R). The value of e_r is determined by the amount of current flowing through the resistor on its way to the capacitor. At time t_0 the current flowing to the capacitor is maximum. Thus, the voltage drop across the resistor is maximum ($E = IR$). As time progresses toward time t_1 , the current flowing to the capacitor steadily decreases and causes the voltage developed across the resistor (R) to steadily decrease. When time t_1 is reached, current flowing to the capacitor is stopped and the voltage developed across the resistor has decreased to zero.

You should remember that capacitance opposes a change in voltage. This is shown by comparing graph (A) to graph (D). In graph (A) the voltage changed instantly from 0 volts to 6 volts across the circuit, while the voltage developed across the capacitor in graph (D) took the entire time interval from time t_0 to time t_1 to reach 6 volts. The reason for this is that in the first instant at time t_0 , maximum current flows through R and the entire circuit voltage is dropped across the resistor. The voltage impressed across the capacitor at t_0 is zero volts. As time progresses toward t_1 , the decreasing current causes progressively less voltage to be dropped across the resistor (R), and more voltage builds up across the capacitor (C). At time t_1 , the voltage felt across the capacitor is equal to the source voltage (6 volts), and the voltage dropped across the resistor (R) is equal to zero. This is the complete charge cycle of the capacitor.

As you may have noticed, the processes which take place in the time interval t_0 to t_1 in a series RC circuit are exactly opposite to those in a series LR circuit.

For your comparison, the important points of the charge cycle of RC and LR circuits are summarized in table 3-1.

Table 3-1.—Summary of Capacitive and Inductive Characteristics

		TIME ZERO (t_0)	TIME BETWEEN t_0 AND t_1	TIME ONE (t_1)
CIRCUIT CURRENT		MAXIMUM	DECREASING	ZERO
		ZERO	INCREASING	MAXIMUM
VOLTAGE DEVELOPED ACROSS THE RESISTOR		MAXIMUM	DECREASING	ZERO
		ZERO	INCREASING	MAXIMUM
VOLTAGE DEVELOPED ACROSS CAPACITOR/ INDUCTOR		ZERO	INCREASING	MAXIMUM
		MAXIMUM	DECREASING	ZERO

DISCHARGE CYCLE

In figure 3-10 at time t_0 , the capacitor is fully charged. When S1 is open and S2 closes, the capacitor discharge cycle starts. At the first instant, circuit voltage attempts to go from source potential (6 volts) to zero volts, as shown in graph (A). Remember, though, the capacitor during the charge cycle has stored energy in an electrostatic field.

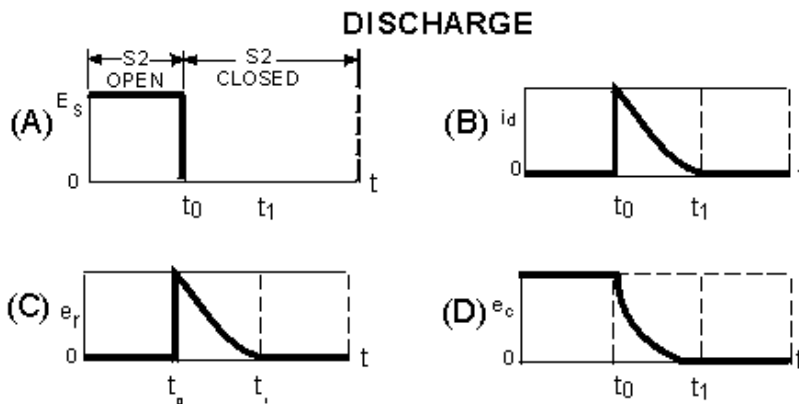
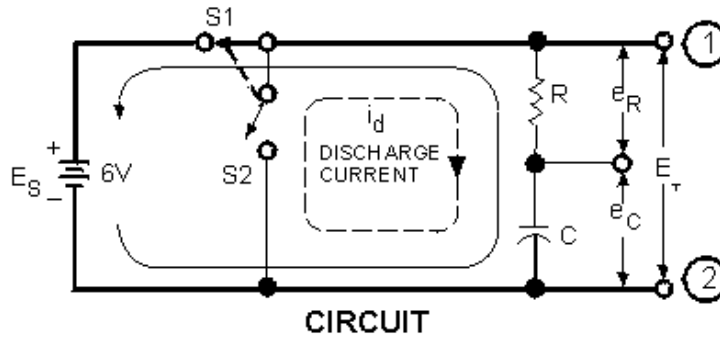

Figure 3-10.—Discharge of an RC Series circuit.

Because S2 is closed at the same time S1 is open, the stored energy of the capacitor now has a path for current to flow. At t_0 , discharge current (i_d) from the bottom plate of the capacitor through the resistor (R) to the top plate of the capacitor (C) is maximum. As time progresses toward t_1 , the discharge current steadily decreases until at time t_1 it reaches zero, as shown in graph (B).

The discharge causes a corresponding voltage drop across the resistor as shown in graph (C). At time t_0 , the current through the resistor is maximum and the voltage drop (e_r) across the resistor is maximum. As the current through the resistor decreases, the voltage drop across the resistor decreases until at t_1 it has reached a value of zero. Graph (D) shows the voltage across the capacitor (e_c) during the discharge cycle. At time t_0 the voltage is maximum and as time progresses toward time t_1 , the energy stored in the capacitor is depleted. At the same time the voltage across the resistor is decreasing, the voltage (e) across the capacitor is decreasing until at time t_1 the voltage (e_c) reaches zero.

By comparing graph (A) with graph (D) of figure 3-10, you can see the effect that capacitance has on a change in voltage. If the circuit had not contained a capacitor, the voltage would have ceased at the instant S1 was opened at time t_0 . Because the capacitor is in the circuit, voltage is applied to the circuit until the capacitor has discharged completely at t_1 . The effect of capacitance has been to oppose this change in voltage.

- Q12. At what instant does the greatest voltage appear across the resistor in a series RC circuit when the capacitor is charging?
- Q13. What is the voltage drop across the resistor in an RC charging circuit when the charge on the capacitor is equal to the battery voltage?

RC TIME CONSTANT

The time required to charge a capacitor to 63 percent (actually 63.2 percent) of full charge or to discharge it to 37 percent (actually 36.8 percent) of its initial voltage is known as the TIME CONSTANT (TC) of the circuit. The charge and discharge curves of a capacitor are shown in figure 3-11. Note that the charge curve is like the curve in figure 3-9, graph (D), and the discharge curve like the curve in figure 3-9, graph (B).

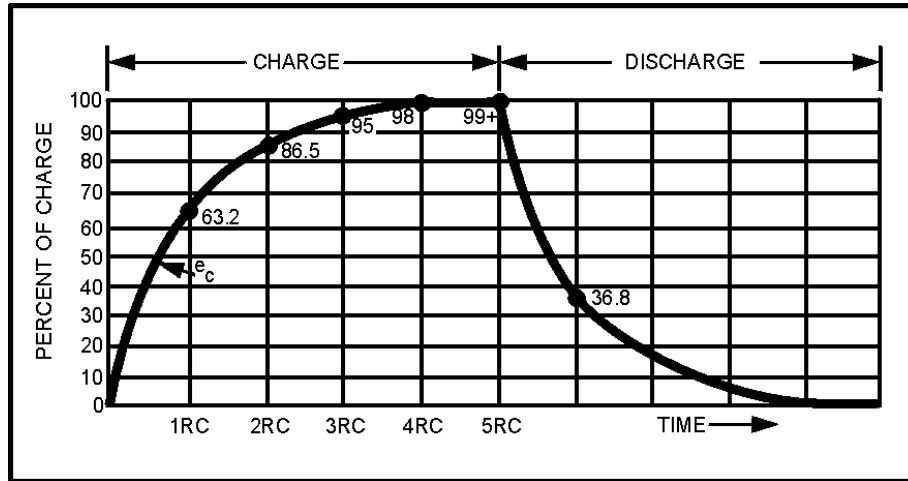

Figure 3-11.—RC time constant.

The value of the time constant in seconds is equal to the product of the circuit resistance in ohms and the circuit capacitance in farads. The value of one time constant is expressed mathematically as $t = RC$. Some forms of this formula used in calculating RC time constants are:

$$t \text{ (in seconds)} = R \text{ (in ohms)} \times C \text{ (in farads)}$$

$$t \text{ (in seconds)} = R \text{ (in megohms)} \times C \text{ (in microfarads)}$$

$$t \text{ (in microseconds)} = R \text{ (in ohms)} \times C \text{ (in microfarads)}$$

$$t \text{ (in microseconds)} = R \text{ (in megohms)} \times C \text{ (in picofarads)}$$

Q14. What is the RC time constant of a series RC circuit that contains a 12-megohm resistor and a 12-microfarad capacitor?

UNIVERSAL TIME CONSTANT CHART

Because the impressed voltage and the values of R and C or R and L in a circuit are usually known, a UNIVERSAL TIME CONSTANT CHART (fig. 3-12) can be used to find the time constant of the circuit. Curve A is a plot of both capacitor voltage during charge and inductor current during growth. Curve B is a plot of both capacitor voltage during discharge and inductor current during decay.

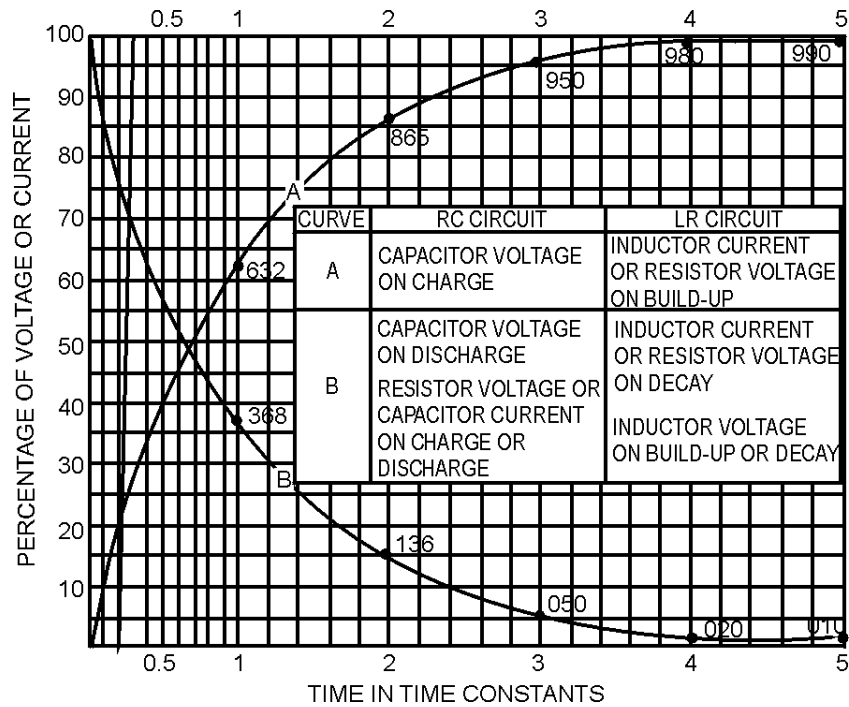

Figure 3-12.—Universal time constant chart for RC and RL circuit.

The time scale (horizontal scale) is graduated in terms of the RC or L/R time constants so that the curves may be used for any value of R and C or L and R. The voltage and current scales (vertical scales) are graduated in terms of percentage of the maximum voltage or current so that the curves may be used for any value of voltage or current. If the time constant and the initial or final voltage for the circuit in question are known, the voltages across the various parts of the circuit can be obtained from the curves for any time after the switch is closed, either on charge or discharge. The same reasoning is true of the current in the circuit.

The following problem illustrates how the universal time constant chart may be used.

An RC circuit is to be designed in which a capacitor (C) must charge to 20 percent (0.20) of the maximum charging voltage in 100 microseconds (0.0001 second). Because of other considerations, the resistor (R) must have a value of 20,000 ohms. What value of capacitance is needed?

Given: Percent of charge = 20% (.20)

$t = 100 \mu s$

$R = 20,000 \Omega$

Find: The capacitance of capacitor C.

Solution: Because the only values given are in units of time and resistance, a variation of the formula to find RC time is used:

$$RC = R \times C$$

where: 1 RC time constant = $R \times C$
and R is known.

Transpose the formula to:

$$C = \frac{RC}{R}$$

Find the value of RC by referring to the universal time constant chart in figure 3-12 and proceed as follows:

- Locate the 20 point on the vertical scale at the left side of the chart (percentage).
- Follow the horizontal line from this point to intersect curve A.
- Follow an imaginary vertical line from the point of intersection on curve A downward to cross the RC scale at the bottom of the chart.

Note that the vertical line crosses the horizontal scale at about .22 RC as illustrated below:

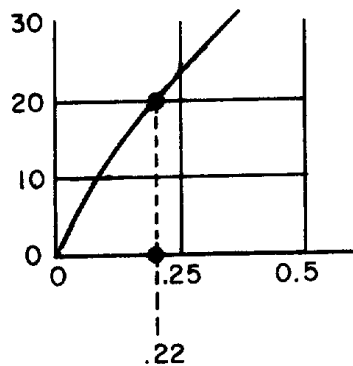

The value selected from the graph means that a capacitor (including the one you are solving for) will reach twenty percent of full charge in twenty-two one hundredths (.22) of one RC time constant. Remember that it takes $100 \mu s$ for the capacitor to reach 20% of full charge. Since $100 \mu s$ is equal to .22 RC (twenty-two one-hundredths), then the time required to reach one RC time constant must be equal to:

$$.22 RC = 100 \mu s$$

$$RC = \frac{1}{.22} \times 100 \mu s$$

$$RC = \frac{100 \mu s}{.22}$$

$$RC = 454.54 \mu s \text{ (rounded off to } 455 \mu s)$$

$$RC = 455 \mu s$$

Now use the following formula to find C:

$$C = \frac{RC}{R}$$
$$C = \frac{455 \mu s}{20,000 \text{ ohms}}$$
$$C = 0.0227 \mu F$$
$$C = .023 \mu F$$

To summarize the above procedures, the problem and solution are shown below without the step by step explanation.

Given: Percent of charge = 20% (.20)
t = 100 μs
R = 20,000 ohms

Transpose the RC time constant formula as follows:

$$R \times C = RC$$
$$C = \frac{RC}{R}$$

Find: RC

$$.22 RC = 100 \mu s$$
$$RC = \frac{100 \mu s}{.22}$$
$$RC = 455 \mu s$$

Substitute the R and RC values into the formula:

$$C = \frac{RC}{R}$$
$$C = \frac{455 \mu s}{20,000} \text{ ohms}$$
$$C = .023 \mu s$$

The graphs shown in figure 3-11 and 3-12 are not entirely complete. That is, the charge or discharge (or the growth or decay) is not quite complete in 5 RC or 5 L/R time constants. However, when the values reach 0.99 of the maximum (corresponding to 5 RC or 5 L/R), the graphs may be considered accurate enough for all practical purposes.

- Q15. A circuit is to be designed in which a capacitor must charge to 40 percent of the maximum charging voltage in 200 microseconds. The resistor to be used has a resistance of 40,000 ohms. What size capacitor must be used? (Use the universal time constant chart in figure 3-12.)*

CAPACITORS IN SERIES AND PARALLEL

Capacitors may be connected in series or in parallel to obtain a resultant value which may be either the sum of the individual values (in parallel) or a value less than that of the smallest capacitance (in series).

CAPACITORS IN SERIES

The overall effect of connecting capacitors in series is to move the plates of the capacitors further apart. This is shown in figure 3-13. Notice that the junction between C1 and C2 has both a negative and a positive charge. This causes the junction to be essentially neutral. The total capacitance of the circuit is developed between the left plate of C1 and the right plate of C2. Because these plates are farther apart, the total value of the capacitance in the circuit is decreased. Solving for the total capacitance (C_T) of capacitors connected in series is similar to solving for the total resistance (R_T) of resistors connected in parallel.

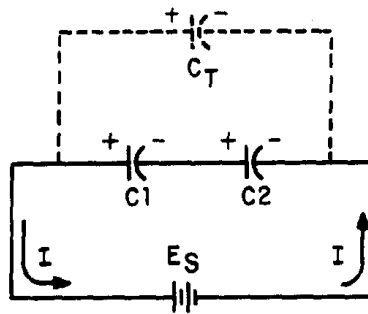

Figure 3-13.—Capacitors in series.

Note the similarity between the formulas for R_T and C_T :

$$R_T = \frac{1}{\frac{1}{R_1} + \frac{1}{R_2} + \dots + \frac{1}{R_n}}$$
$$C_T = \frac{1}{\frac{1}{C_1} + \frac{1}{C_2} + \dots + \frac{1}{C_n}}$$

If the circuit contains more than two capacitors, use the above formula. If the circuit contains only two capacitors, use the below formula:

$$C_T = \frac{C_1 \times C_2}{C_1 + C_2}$$

Note: All values for C_T , C_1 , C_2 , C_3 ,... C_n should be in farads. It should be evident from the above formulas that the total capacitance of capacitors in series is less than the capacitance of any of the individual capacitors.

Example: Determine the total capacitance of a series circuit containing three capacitors whose values are 0.01 μF , 0.25 μF , and 50,000 pF, respectively.

Given: $C_1 = 0.01 \mu s$
 $C_2 = 0.25 \mu s$
 $C_3 = 50,000 \text{ pF}$

Solution:

$$C_T = \frac{1}{\frac{1}{C_1} + \frac{1}{C_2} + \frac{1}{C_3}}$$

$$C_T = \frac{1}{\frac{1}{.01 \mu\text{F}} + \frac{1}{.25 \mu\text{F}} + \frac{1}{50,000 \text{ pF}}}$$

$$C_T = \frac{1}{\frac{1}{1 \times 10^{-8}} + \frac{1}{25 \times 10^{-8}} + \frac{1}{5 \times 10^{-8}}} \text{ F}$$

$$C_T = \frac{1}{100 \times 10^6 + 4 \times 10^6 + 20 \times 10^6} \text{ F}$$

$$C_T = \frac{1}{124 \times 10^6} \text{ F}$$

$$C_T = 0.008 \mu\text{F}$$

The total capacitance of $0.008 \mu\text{F}$ is slightly smaller than the smallest capacitor ($0.01 \mu\text{F}$).

CAPACITORS IN PARALLEL

When capacitors are connected in parallel, one plate of each capacitor is connected directly to one terminal of the source, while the other plate of each capacitor is connected to the other terminal of the source. Figure 3-14 shows all the negative plates of the capacitors connected together, and all the positive plates connected together. C_T , therefore, appears as a capacitor with a plate area equal to the sum of all the individual plate areas. As previously mentioned, capacitance is a direct function of plate area. Connecting capacitors in parallel effectively increases plate area and thereby increases total capacitance.

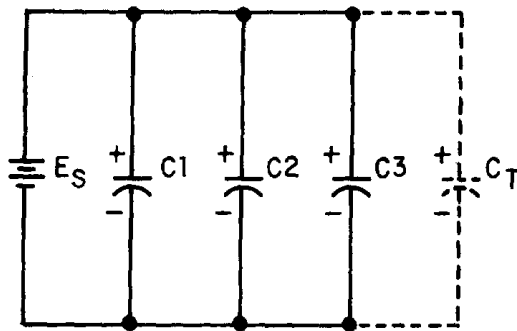

Figure 3-14.—Parallel capacitive circuit.

For capacitors connected in parallel the total capacitance is the sum of all the individual capacitances. The total capacitance of the circuit may be calculated using the formula:

$$C_T = C_1 + C_2 + C_3 + \dots + C_n$$

where all capacitances are in the same units.

Example: Determine the total capacitance in a parallel capacitive circuit containing three capacitors whose values are $0.03 \mu\text{F}$, $2.0 \mu\text{F}$, and $0.25 \mu\text{F}$, respectively.

Given: $C_1 = 0.03 \mu\text{F}$

$$C_2 = 2 \mu\text{F}$$

$$C_3 = 0.25 \mu\text{F}$$

Solution: $C_T = C_1 + C_2 + C_3$

$$C_T = 0.03 \mu\text{F} + 2.0 \mu\text{F} + 0.25 \mu\text{F}$$

$$C_T = 2.28 \mu\text{F}$$

- Q16. What is the total capacitance of a circuit that contains two capacitors ($10 \mu\text{F}$ and $0.1 \mu\text{F}$) wired together in series?*
- Q17. What is the total capacitance of a circuit in which four capacitors ($10 \mu\text{F}$, $21 \mu\text{F}$, $0.1 \mu\text{F}$ and $2 \mu\text{F}$) are connected in parallel?*

FIXED CAPACITOR

A fixed capacitor is constructed in such manner that it possesses a fixed value of capacitance which cannot be adjusted. A fixed capacitor is classified according to the type of material used as its dielectric, such as paper, oil, mica, or electrolyte.

A PAPER CAPACITOR is made of flat thin strips of metal foil conductors that are separated by waxed paper (the dielectric material). Paper capacitors usually range in value from about 300 picofarads to about 4 microfarads. The working voltage of a paper capacitor rarely exceeds 600 volts. Paper capacitors are sealed with wax to prevent the harmful effects of moisture and to prevent corrosion and leakage.

Many different kinds of outer covering are used on paper capacitors, the simplest being a tubular cardboard covering. Some types of paper capacitors are encased in very hard plastic. These types are very rugged and can be used over a much wider temperature range than can the tubular cardboard type. Figure 3-15(A) shows the construction of a tubular paper capacitor; part 3-15(B) shows a completed cardboard-encased capacitor.

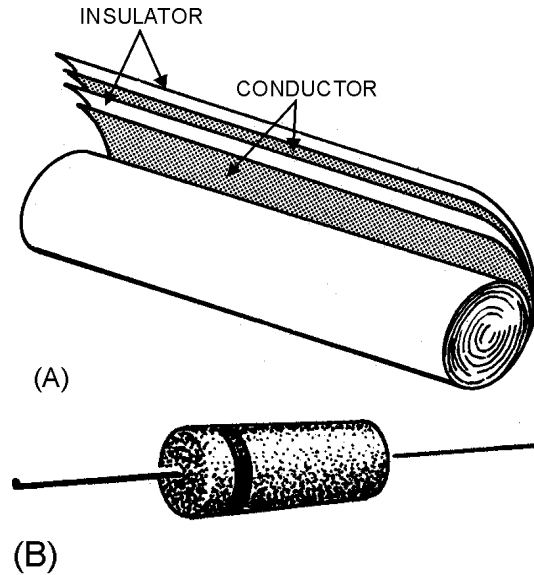

Figure 3-15.—Paper capacitor.

A MICA CAPACITOR is made of metal foil plates that are separated by sheets of mica (the dielectric). The whole assembly is encased in molded plastic. Figure 3-16(A) shows a cut-away view of a mica capacitor. Because the capacitor parts are molded into a plastic case, corrosion and damage to the plates and dielectric are prevented. In addition, the molded plastic case makes the capacitor mechanically stronger. Various types of terminals are used on mica capacitors to connect them into circuits. These terminals are also molded into the plastic case.

Mica is an excellent dielectric and can withstand a higher voltage than can a paper dielectric of the same thickness. Common values of mica capacitors range from approximately 50 picofarads to 0.02 microfarad. Some different shapes of mica capacitors are shown in figure 3-16(B).

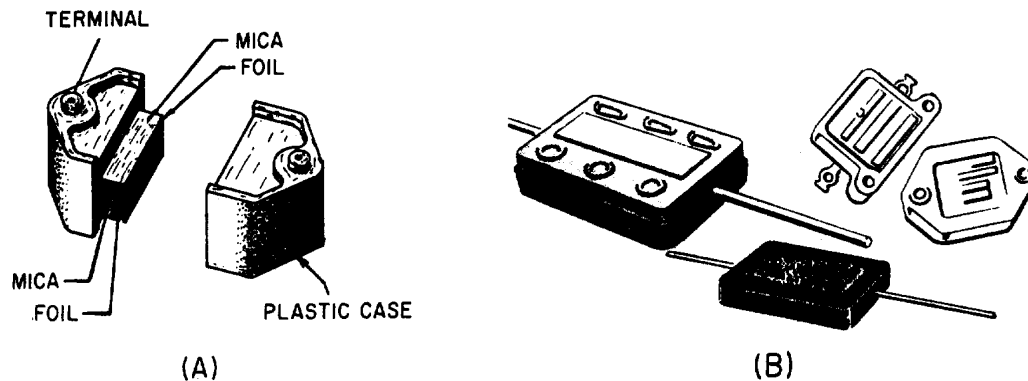

Figure 3-16.—Typical mica capacitors.

A CERAMIC CAPACITOR is so named because it contains a ceramic dielectric. One type of ceramic capacitor uses a hollow ceramic cylinder as both the form on which to construct the capacitor and as the dielectric material. The plates consist of thin films of metal deposited on the ceramic cylinder.

A second type of ceramic capacitor is manufactured in the shape of a disk. After leads are attached to each side of the capacitor, the capacitor is completely covered with an insulating moisture-proof coating. Ceramic capacitors usually range in value from 1 picofarad to 0.01 microfarad and may be used with voltages as high as 30,000 volts. Some different shapes of ceramic capacitors are shown in figure 3-17.

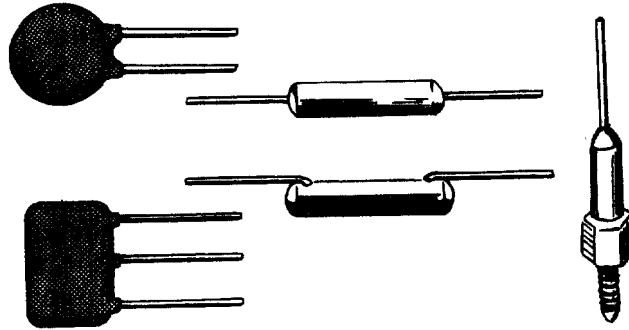
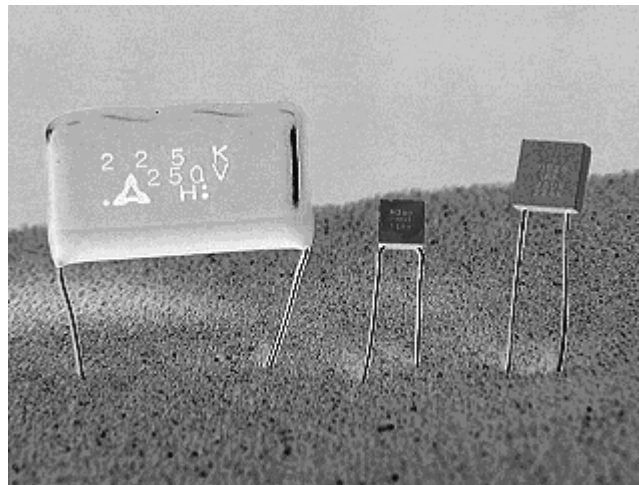

Figure 3-17.—Ceramic capacitors.



Examples of ceramic capacitors.

An ELECTROLYTIC CAPACITOR is used where a large amount of capacitance is required. As the name implies, an electrolytic capacitor contains an electrolyte. This electrolyte can be in the form of a liquid (wet electrolytic capacitor). The wet electrolytic capacitor is no longer in popular use due to the care needed to prevent spilling of the electrolyte.

A dry electrolytic capacitor consists essentially of two metal plates separated by the electrolyte. In most cases the capacitor is housed in a cylindrical aluminum container which acts as the negative terminal of the capacitor (see fig. 3-18). The positive terminal (or terminals if the capacitor is of the multisection type) is a lug (or lugs) on the bottom end of the container. The capacitance value(s) and the voltage rating of the capacitor are generally printed on the side of the aluminum case.

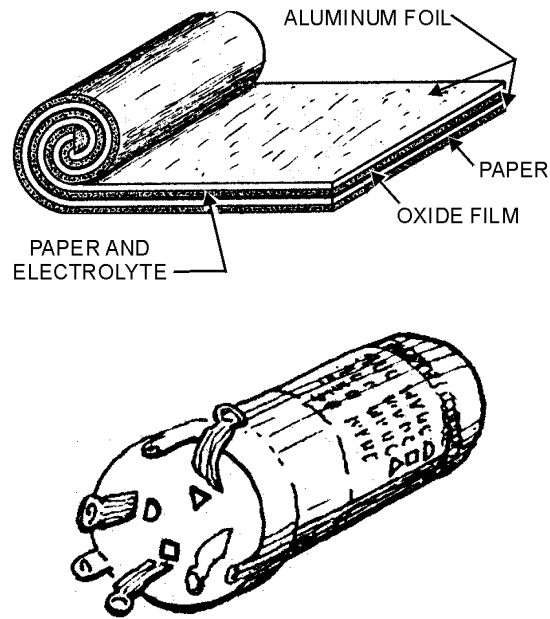

Figure 3-18.—Construction of an electrolytic capacitor.

An example of a multisection electrolytic capacitor is illustrated in figure 3-18(B). The four lugs at the end of the cylindrical aluminum container indicates that four electrolytic capacitors are enclosed in the can. Each section of the capacitor is electrically independent of the other sections. It is possible for one section to be defective while the other sections are still good. The can is the common negative connection to the four capacitors. Separate terminals are provided for the positive plates of the capacitors. Each capacitor is identified by an embossed mark adjacent to the lugs, as shown in figure 3-18(B). Note the identifying marks used on the electrolytic capacitor are the half moon, the triangle, the square, and no embossed mark. By looking at the bottom of the container and the identifying sheet pasted to the side of the container, you can easily identify the value of each section.

Internally, the electrolytic capacitor is constructed similarly to the paper capacitor. The positive plate consists of aluminum foil covered with an extremely thin film of oxide. This thin oxide film (which is formed by an electrochemical process) acts as the dielectric of the capacitor. Next to and in contact with the oxide is a strip of paper or gauze which has been impregnated with a paste-like electrolyte. The electrolyte acts as the negative plate of the capacitor. A second strip of aluminum foil is then placed against the electrolyte to provide electrical contact to the negative electrode (the electrolyte). When the three layers are in place they are rolled up into a cylinder as shown in figure 3-18(A).

An electrolytic capacitor has two primary disadvantages compared to a paper capacitor in that the electrolytic type is **POLARIZED** and has a **LOW LEAKAGE RESISTANCE**. This means that should the positive plate be accidentally connected to the negative terminal of the source, the thin oxide film dielectric will dissolve and the capacitor will become a conductor (i.e., it will short). The polarity of the terminals is normally marked on the case of the capacitor. Since an electrolytic capacitor is polarity sensitive, its use is ordinarily restricted to a dc circuit or to a circuit where a small ac voltage is superimposed on a dc voltage. Special electrolytic capacitors are available for certain ac applications, such as a motor starting capacitor. Dry electrolytic capacitors vary in size from about 4 microfarads to several thousand microfarads and have a working voltage of approximately 500 volts.

The type of dielectric used and its thickness govern the amount of voltage that can safely be applied to the electrolytic capacitor. If the voltage applied to the capacitor is high enough to cause the atoms of the

dielectric material to become ionized, arcing between the plates will occur. In most other types of capacitors, arcing will destroy the capacitor. However, an electrolytic capacitor has the ability to be self-healing. If the arcing is small, the electrolytic will regenerate itself. If the arcing is too large, the capacitor will not self-heal and will become defective.

OIL CAPACITORS are often used in high-power electronic equipment. An oil-filled capacitor is nothing more than a paper capacitor that is immersed in oil. Since oil impregnated paper has a high dielectric constant, it can be used in the production of capacitors having a high capacitance value. Many capacitors will use oil with another dielectric material to prevent arcing between the plates. If arcing should occur between the plates of an oil-filled capacitor, the oil will tend to reseal the hole caused by the arcing. Such a capacitor is referred to as a SELF-HEALING capacitor.

VARIABLE CAPACITOR

A variable capacitor is constructed in such manner that its value of capacitance can be varied. A typical variable capacitor (adjustable capacitor) is the rotor-stator type. It consists of two sets of metal plates arranged so that the rotor plates move between the stator plates. Air is the dielectric. As the position of the rotor is changed, the capacitance value is likewise changed. This type of capacitor is used for tuning most radio receivers. Its physical appearance and its symbol are shown in figure 3-19.

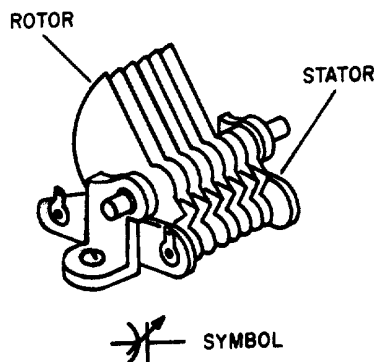

Figure 3-19.—Rotor-stator type variable capacitor.

Another type of variable capacitor (trimmer capacitor) and its symbol are shown in figure 3-20. This capacitor consists of two plates separated by a sheet of mica. A screw adjustment is used to vary the distance between the plates, thereby changing the capacitance.

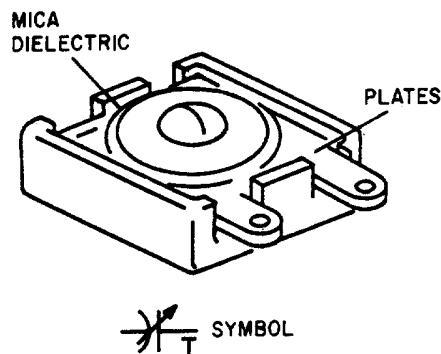

Figure 3-20.—Trimmer capacitor.

Q18.

- a. An oxide-film dielectric is used in what type of capacitor?
- b. A screw adjustment is used to vary the distance between the plates of what type of capacitor?

COLOR CODES FOR CAPACITORS

Although the capacitance value may be printed on the body of a capacitor, it may also be indicated by a color code. The color code used to represent capacitance values is similar to that used to represent resistance values. The color codes currently in use are the Joint Army-Navy (JAN) code and the Radio Manufacturers' Association (RMA) code.

For each of these codes, colored dots or bands are used to indicate the value of the capacitor. A mica capacitor, it should be noted, may be marked with either three dots or six dots. Both the three- and the six-dot codes are similar, but the six-dot code contains more information about electrical ratings of the capacitor, such as working voltage and temperature coefficient.

The capacitor shown in figure 3-21 represents either a mica capacitor or a molded paper capacitor. To determine the type and value of the capacitor, hold the capacitor so that the three arrows point left to right (>). The first dot at the base of the arrow sequence (the left-most dot) represents the capacitor TYPE. This dot is either black, white, silver, or the same color as the capacitor body. Mica is represented by a black or white dot and paper by a silver dot or dot having the same color as the body of the capacitor. The two dots to the immediate right of the type dot indicate the first and second digits of the capacitance value. The dot at the bottom right represents the multiplier to be used. The multiplier represents picofarads. The dot in the bottom center indicates the tolerance value of the capacitor.

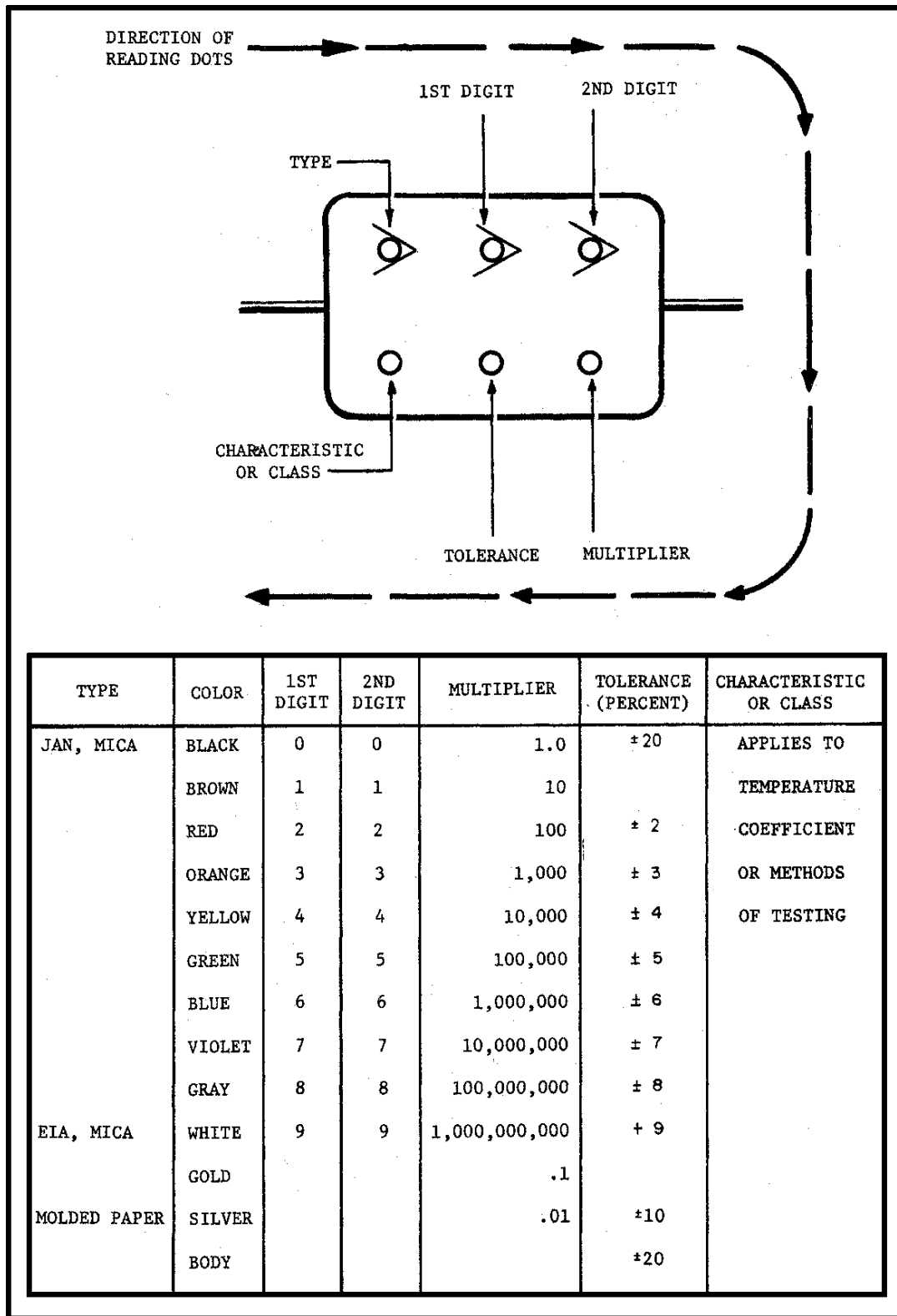
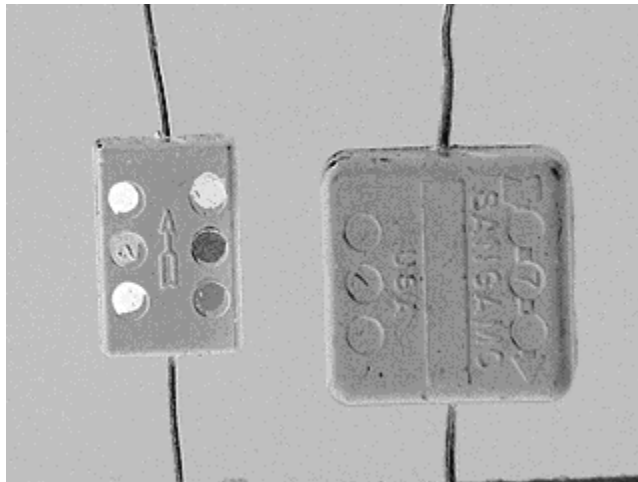
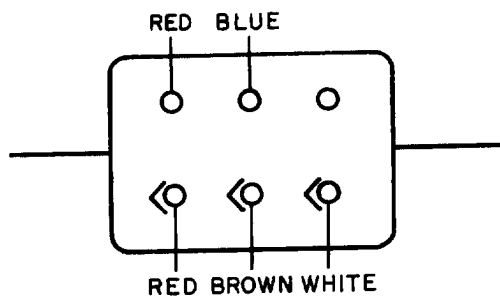

Figure 3-21.—6-dot color code for mica and molded paper capacitors.



Example of mica capacitors.



Example of mica capacitors.

To read the capacitor color code on the above capacitor:

1. Hold the capacitor so the arrows point left to right.

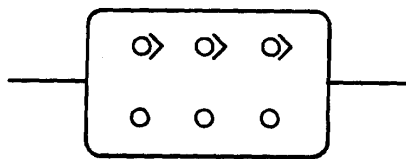

2. Read the first dot.

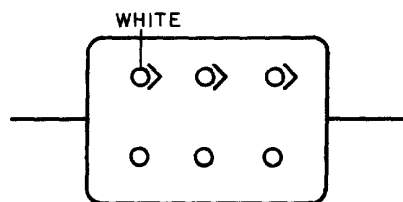

White = mica

3. Read the first digit dot.

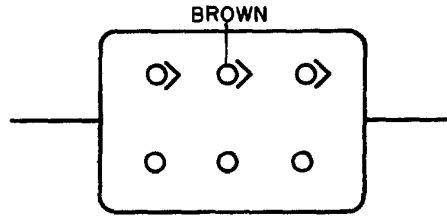

Brown = 1

4. Read the second digit dot and apply it to the first digit.

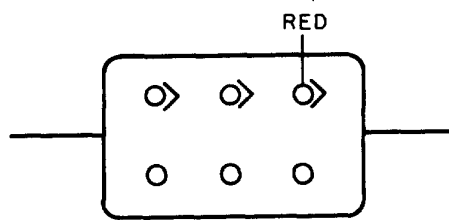

Red = 2 → 12

5. Read the multiplier dot and multiply the first two digits by multiplier. (Remember that the multiplier is in picofarads).

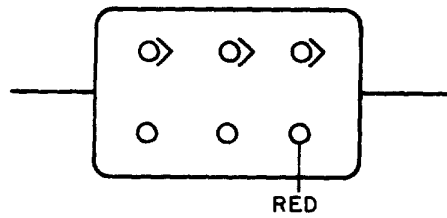

Red = 100 → 12 x 100 = 1200 pF

6. Lastly, read the tolerance dot.

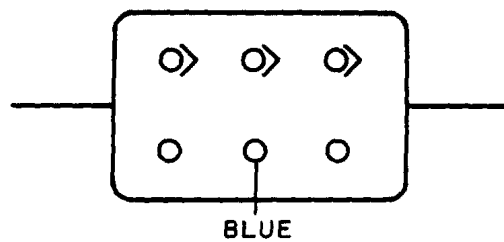

Blue = ±6%

According to the above coding, the capacitor is a mica capacitor whose capacitance is 1200 pF with a tolerance of $\pm 6\%$.

The capacitor shown in figure 3-22 is a tubular capacitor. Because this type of capacitor always has a paper dielectric, the type code is omitted. To read the code, hold the capacitor so the band closest to the end is on the left side; then read left to right. The last two bands (the fifth and sixth bands from the left) represent the voltage rating of the capacitor. This means that if a capacitor is coded red, red, red, yellow, yellow, yellow, it has the following digit values:

- red = 2
- red = 2
- red = $\times 100 \text{ pF}$
- yellow = $\pm 40\%$
- yellow = 4
- yellow = 4

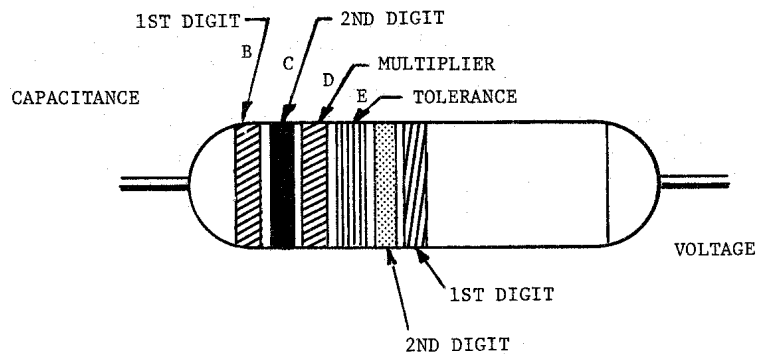

COLOR	CAPACITANCE			TOLERANCE (PERCENT)	VOLTAGE RATING	
	1ST DIGIT	2ND DIGIT	MULTIPLIER		1ST DIGIT	2ND DIGIT
BLACK	0	0	1	± 20	0	0
BROWN	1	1	10		1	1
RED	2	2	100		2	2
ORANGE	3	3	1,000	± 30	3	3
YELLOW	4	4	10,000	± 40	4	4
GREEN	5	5	100,000	± 5	5	5
BLUE	6	6	1,000,000		6	6
VIOLET	7	7			7	7
GRAY	8	8			8	8
WHITE	9	9		± 10	9	9

Figure 3-22.—6-band color code for tubular paper dielectric capacitors.

The six digits indicate a capacitance of 2200 pF with a ± 40 percent tolerance and a working voltage of 44 volts.

The ceramic capacitor is color coded as shown in figure 3-23 and the mica capacitor as shown in figure 3-24. Notice that this type of mica capacitor differs from the one shown in figure 3-21 in that the arrow is solid instead of broken. This type of mica capacitor is read in the same manner as the one shown in figure 3-21, with one exception: the first dot indicates the first digit. (Note: Because this type of capacitor is always mica, there is no need for a type dot.)

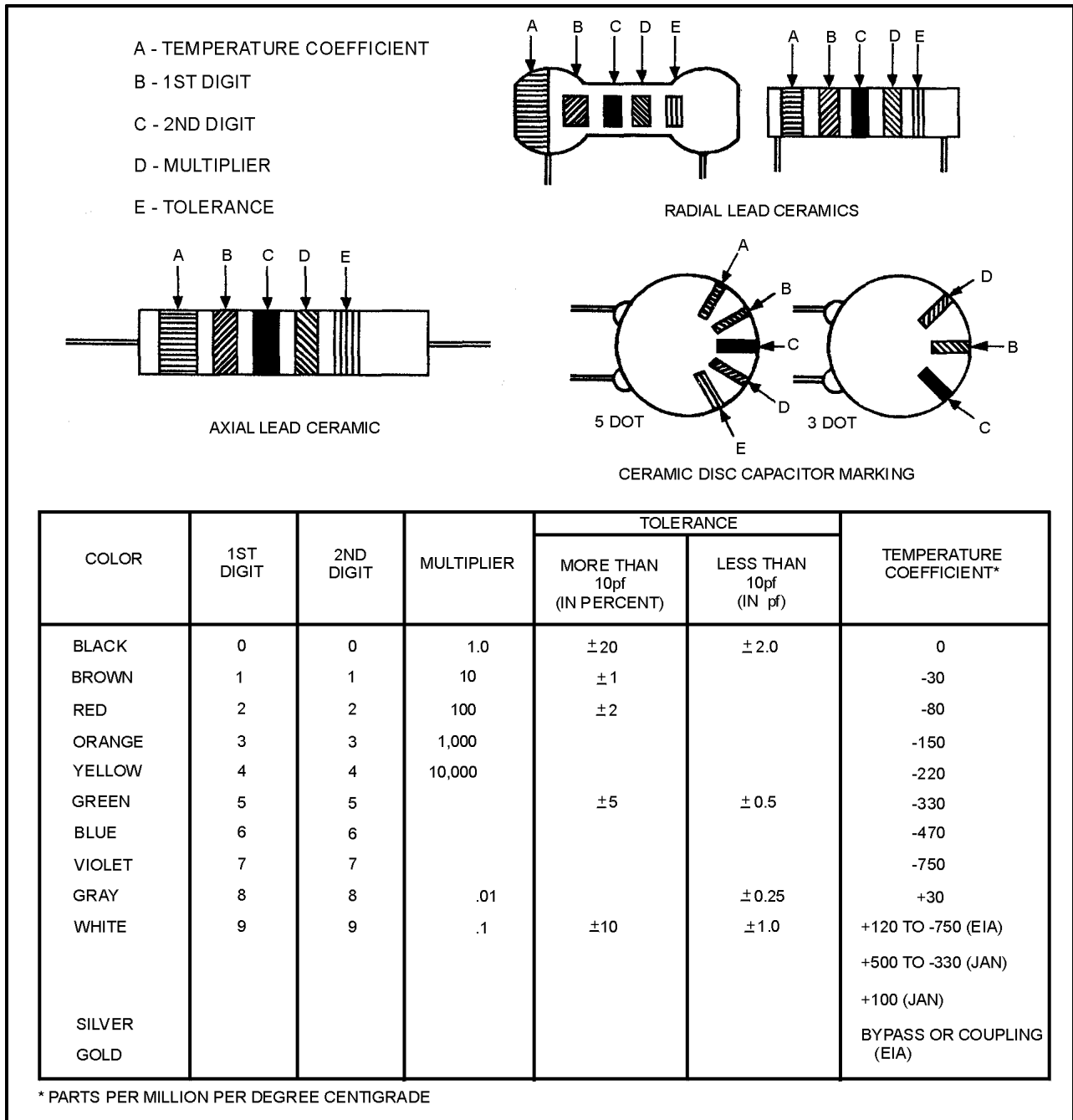
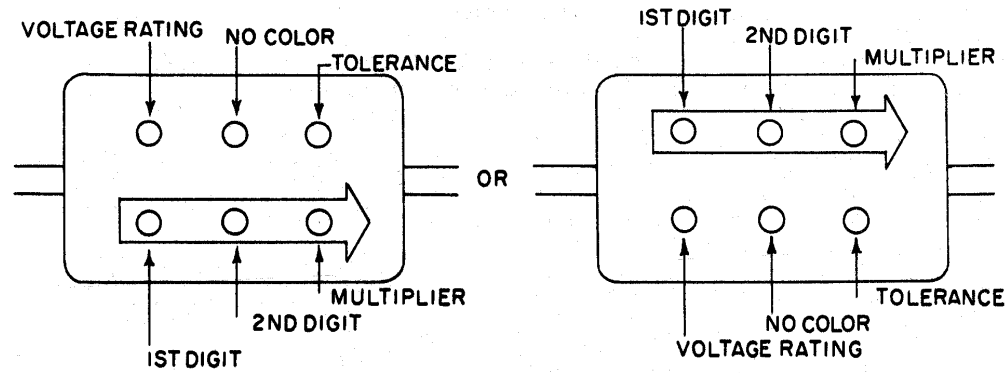

Figure 3-23.—Ceramic capacitor color code.



COLOR	1ST DIGIT	2ND DIGIT	MULTIPLIER	TOLERANCE (PERCENT)	VOLTAGE RATING
BLACK	0	0	1.0		
BROWN	1	1	10	± 1	100
RED	2	2	100	± 2	200
ORANGE	3	3	1,000	± 3	300
YELLOW	4	4	10,000	± 4	400
GREEN	5	5	100,000	± 5	500
BLUE	6	6	1,000,000	± 6	600
VIOLET	7	7	10,000,000	± 7	700
GRAY	8	8	100,000,000	± 8	800
WHITE	9	9	1,000,000,000	± 9	900
GOLD			.1		1000
SILVER			.01	± 10	2000
BODY				± 20	*

* WHERE NO COLOR IS INDICATED, THE VOLTAGE RATING MAY BE AS LOW AS 300 VOLTS.

Figure 3-24.—Mica capacitor color code.

Q19. Examine the three capacitors shown below. What is the capacitance of each?

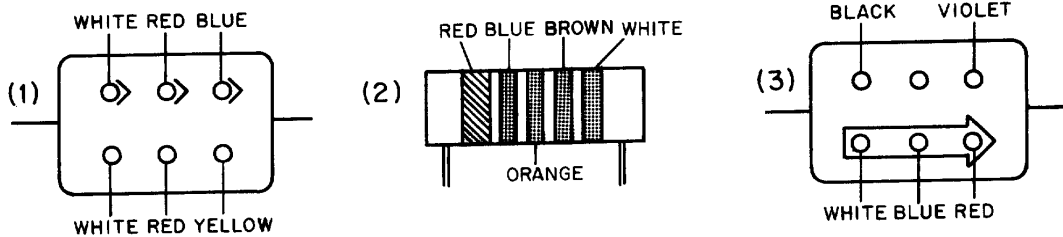

SUMMARY

Before going on to the next chapter, study the below summary to be sure that you understand the important points of this chapter.

THE ELECTROSTATIC FIELD—When a charged body is brought close to another charged body, the bodies either attract or repel one another. (If the charges are alike they repel; if the charges are opposite they attract). The field that causes this effect is called the **ELECTROSTATIC FIELD**. The amount by which two charges attract or repel each other depends upon the size of the charges and the distance between the charges. The electrostatic field (force between two charged bodies) may be represented by lines of force

drawn perpendicular to the charged surfaces. If an electron is placed in the field, it will move toward the positive charge.

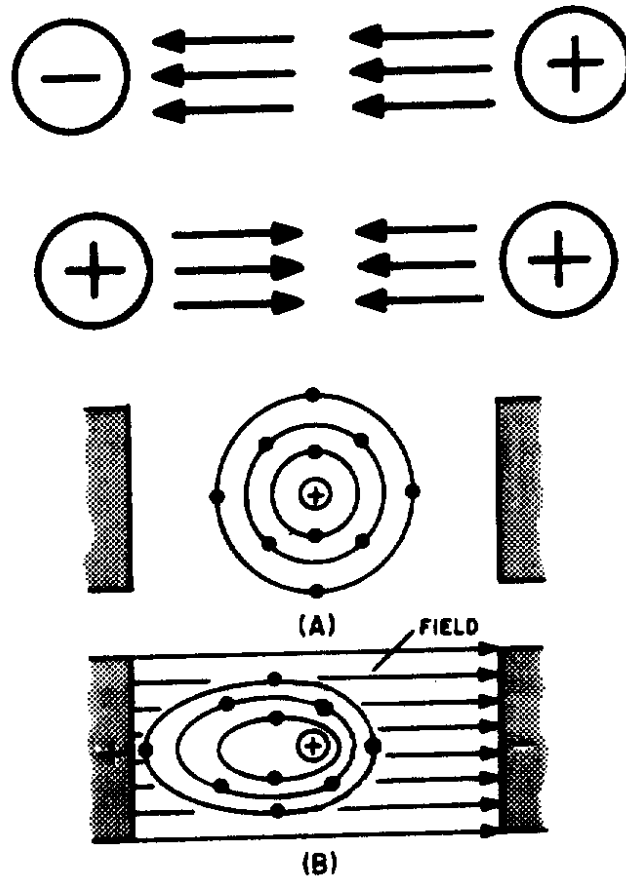

CAPACITANCE—Capacitance is the property of a circuit which OPPOSES any CHANGE in the circuit VOLTAGE. The effect of capacitance may be seen in any circuit where the voltage is changing. Capacitance is usually defined as the ability of a circuit to store electrical energy. This energy is stored in an electrostatic field. The device used in an electrical circuit to store this charge (energy) is called a CAPACITOR. The basic unit of measurement of capacitance is the FARAD (F). A one-farad capacitor will store one coulomb of charge (energy) when a potential of one volt is applied across the capacitor plates. The farad is an enormously large unit of capacitance. More practical units are the microfarad (μF) or the picofarad (pF).

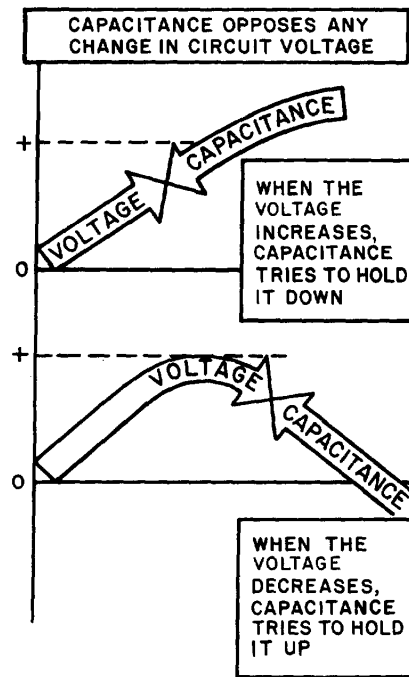

CAPACITOR—A capacitor is a physical device consisting of two pieces of conducting material separated by an insulating material. This insulating material is referred to as the **DIELECTRIC**. Because the dielectric is an insulator, NO current flows through the capacitor. If the dielectric breaks down and becomes a conductor, the capacitor can no longer hold a charge and is useless. The ability of a dielectric to hold a charge without breaking down is referred to as the dielectric strength. The measure of the ability of the dielectric material to store energy is called the dielectric constant. The dielectric constant is a relative value based on 1.0 for a vacuum.

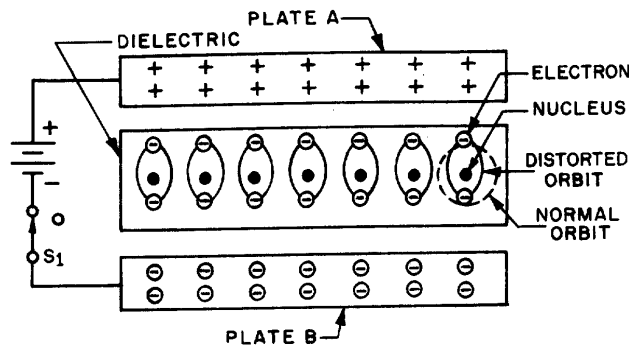

CAPACITORS IN A DC CIRCUIT—When a capacitor is connected to the terminals of a battery, each plate of the capacitor becomes charged. The plate connected to the positive terminal loses electrons. Because this plate has a lack of electrons, it assumes a positive charge. The plate connected to the negative terminal gains electrons. Because the plate has an excess of electrons, it assumes a negative charge. This process continues until the charge across the plates equals the applied voltage. At this point current ceases to flow in the circuit. As long as nothing changes in the circuit, the capacitor will hold its charge and there will be no current in any part of the circuit. If the leads of the capacitor are now shorted together, current again

flows in the circuit. Current will continue to flow until the charges on the two plates become equal. At this point, current ceases to flow. With a dc voltage source, current will flow in the circuit only long enough to charge (or discharge) the capacitor. Thus, a capacitor does NOT allow dc current to flow continuously in a circuit.

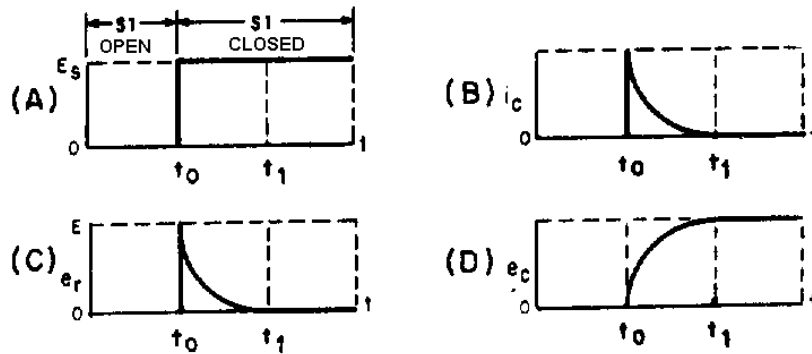
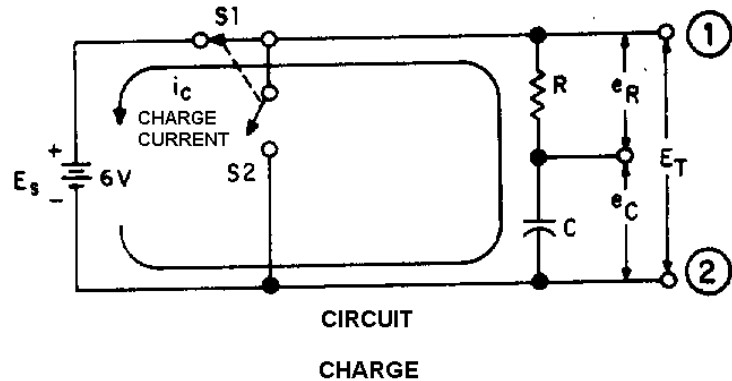
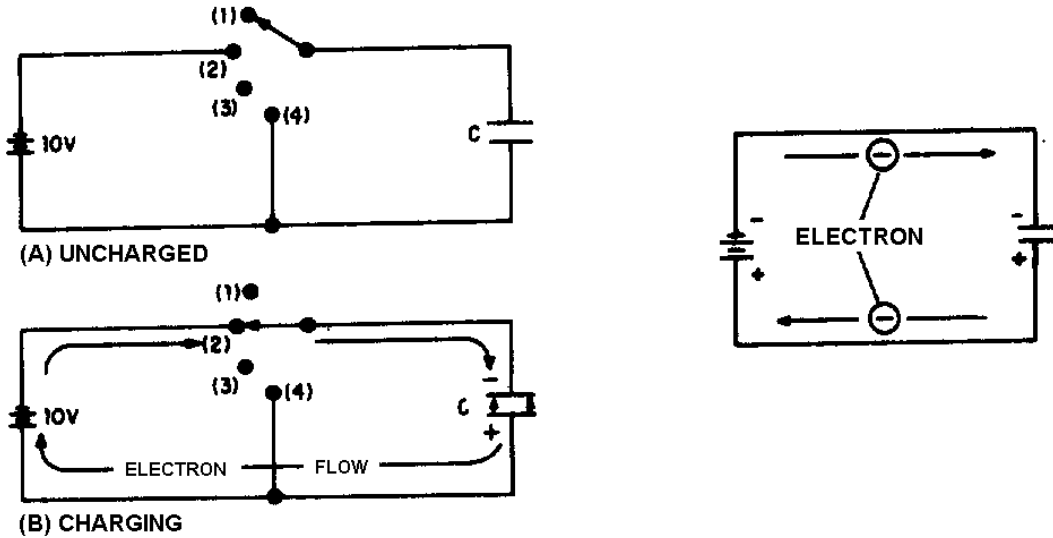

FACTORS AFFECTING CAPACITANCE—There are three factors affecting capacitance. One factor is the area of the plate surfaces. Increasing the area of the plate increases the capacitance. Another

factor is the amount of space between the plates. The closer the plates, the greater will be the electrostatic field. A greater electrostatic field causes a greater capacitance. The plate spacing is determined by the thickness of the dielectric. The third factor affecting capacitance is the dielectric constant. The value of the dielectric constant is dependent upon the type of dielectric used.

WORKING VOLTAGE—The working voltage of a capacitor is the maximum voltage that can be steadily applied to the capacitor without the capacitor breaking down (shorting). The working voltage depends upon the type of material used as the dielectric (the dielectric constant) and the thickness of the dielectric.

CAPACITOR LOSSES—Power losses in a capacitor are caused by dielectric leakage and dielectric hysteresis. Dielectric leakage loss is caused by the leakage current through the resistance in the dielectric. Although this resistance is extremely high, a small amount of current does flow. Dielectric hysteresis may be defined as an effect in a dielectric material similar to the hysteresis found in a magnetic material.

RC TIME CONSTANT—The time required to charge a capacitor to 63.2 percent of the applied voltage, or to discharge the capacitor to 36.8 percent of its charge. The time constant (t) is equal to the product of the resistance and the capacitance. Expressed as a formula:

$$t = RC$$

where t is in seconds, R is in ohms, and C is in farads.

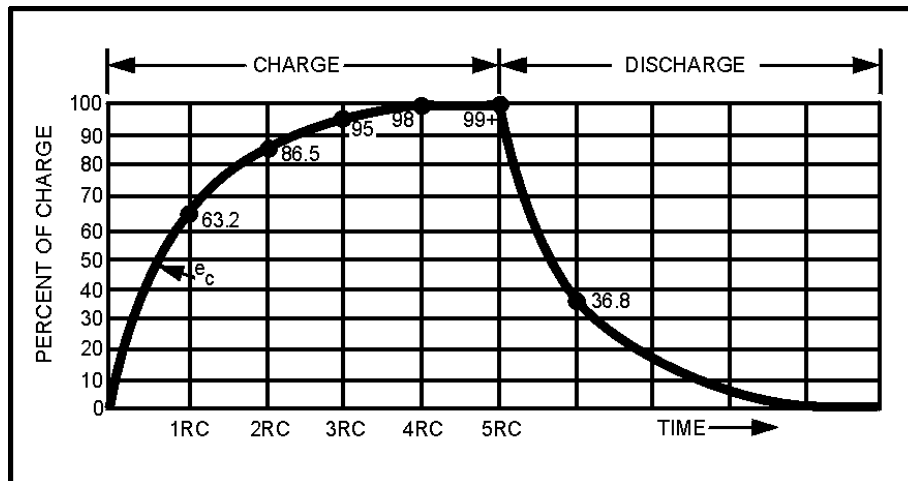

CAPACITORS IN SERIES—The effect of wiring capacitors in series is to increase the distance between plates. This reduces the total capacitance of the circuit. Total capacitance for series connected capacitors may be computed by the formula:

$$C_T = \frac{1}{\frac{1}{C_1} + \frac{1}{C_2} + \frac{1}{C_3} + \dots + \frac{1}{C_n}}$$

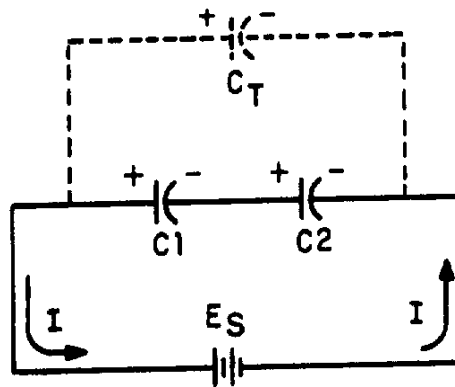

If an electrical circuit contains only two series connected capacitors, C_T may be computed using the following formula:

$$C_T = \frac{C_1 C_2}{C_1 + C_2}$$

CAPACITORS IN PARALLEL—The effect of wiring capacitors in parallel is to increase the plate area of the capacitors. Total capacitance (C_T) may be found using the formula:

$$C_T = C_1 + C_2 \dots + C_n$$

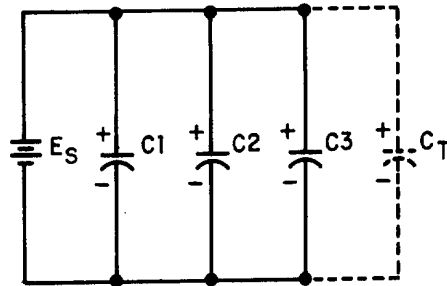

TYPES OF CAPACITORS—Capacitors are manufactured in various forms and may be divided into two main classes—fixed capacitors and variable capacitors. A fixed capacitor is constructed to have a constant or fixed value of capacitance. A variable capacitor allows the capacitance to be varied or adjusted.

ANSWERS TO QUESTIONS Q1. THROUGH Q19.

A1.

- a. A capacitor is a device that stores electrical energy in an electrostatic field.
- b. Capacitance is the property of a circuit which opposes changes in voltage.

A2.

- a. They are polarized from positive to negative.
- b. They radiate from a charged particle in straight lines and do not form closed loops.
- c. They have the ability to pass through any known material.
- d. They have the ability to distort the orbits of electrons circling the nucleus.

A3. Toward the positive charge.

A4. Two pieces of conducting material separated by an insulator.

A5. A farad is the unit of capacitance. A capacitor has a capacitance of 1 farad when a difference of 1 volt will charge it with 1 coulomb of electrons.

A6.

- a. One microfarad equals 10^{-6} farad.
- b. One picofarad equals 10^{-12} farad.

A7.

- a. The area of the plates.
- b. The distance between the plates.
- c. The dielectric constant of the material between the plates.

A8.

4372 picofarads

$$C = .2249 \left(\frac{KA}{d} \right)$$

$$C = .2249 \left(\frac{81 \times 6}{.025} \right)$$

$$C = 4372 \text{ (Rounded off)}$$

A9.

- a. *Hysteresis*
- b. *Dielectric leakage*

A10.

- a. *It is the maximum voltage the capacitor can work without risk of damage.*
- b. *900 volts.*

A11.

- a. *When the capacitor is charging, electrons accumulate on the negative plate and leave the positive plate until the charge on the capacitor is equal to the battery voltage.*
- b. *When the capacitor is discharging, electrons flow from the negatively charged plate to the positively charged plate until the charge on each plate is neutral.*

A12. *At the instant of the initiation of the action.*

A13. *Zero.*

A14.

144 seconds

$$t = R (\text{megohms}) \times C (\text{microfarads})$$

$$t = 12 \times 12$$

$$t = 144 \text{ seconds}$$

A15.

.01 microfarads 40% from the graph = .5

$$RC = \frac{200}{.5}$$

$$RC = 400 \text{ microseconds}$$

$$C = \frac{t}{R}$$

$$C = \frac{400 \mu s}{40,000 \Omega}$$

$$C = .01 \mu F = 10,000 \text{ pF}$$

A16.

. $1\mu\text{F}$

$$C_T = \frac{C_1 C_2}{C_1 + C_2}$$

$$C_T = \frac{10 \times 0.1}{10 + 0.1} \mu\text{F}$$

$$C_T = \frac{1}{10.1} \mu\text{F}$$

$$C_T = .099 \mu\text{F} \text{ or } 0.1\mu\text{F}$$

A17.

$33.1\mu\text{F}$

$$C_T = C_1 + C_2 + C_3 + C_4$$

$$C_T = 10 \mu\text{F} + 21 \mu\text{F} + 0.1 \mu\text{F} + 2 \mu\text{F}$$

$$C_T = 33.1 \mu\text{F}$$

A18.

a. *Electrolytic capacitor*

b. *Trimmer capacitor*

A19.

a. $26 \mu\text{F}$ or $260,000 \text{ pF}$

b. 630 pF

c. 9600 pF