

---

# Bridge Components and Elements (BIRM)

Course No: S02-010

Credit: 2 PDH

---

Mark Rossow, PhD, PE, Retired

---



Continuing Education and Development, Inc.  
9 Greyridge Farm Court  
Stony Point, NY 10980

P: (877) 322-5800

F: (877) 322-4774

[info@cedengineering.com](mailto:info@cedengineering.com)

---

# Table of Contents

---

## Basic Concepts Primer

---

|       |   |        |
|-------|---|--------|
| P.1   | Bridge Components and Elements.....     | P.1.1  |
| P.1.1 | Introduction.....                       | P.1.1  |
| P.1.2 | NBIS Structure Length.....              | P.1.1  |
| P.1.3 | Major Bridge Components.....            | P.1.1  |
| P.1.4 | Basic Member Shapes.....                | P.1.2  |
|       | Timber Shapes.....                      | P.1.2  |
|       | Planks.....                             | P.1.3  |
|       | Beams.....                              | P.1.3  |
|       | Piles.....                              | P.1.4  |
|       | Concrete Shapes.....                    | P.1.4  |
|       | Cast-in-Place Flexural Shapes.....      | P.1.5  |
|       | Precast Flexural Shapes.....            | P.1.6  |
|       | Axially-Loaded Compression Members..... | P.1.8  |
|       | Iron Shapes.....                        | P.1.8  |
|       | Cast Iron.....                          | P.1.9  |
|       | Wrought Iron.....                       | P.1.9  |
|       | Steel Shapes.....                       | P.1.10 |
|       | Rolled Shapes.....                      | P.1.10 |
|       | Built-up Shapes.....                    | P.1.13 |
|       | Cables.....                             | P.1.15 |
| P.1.5 | Connections.....                        | P.1.16 |
|       | Pin Connections.....                    | P.1.17 |
|       | Riveted Connections.....                | P.1.18 |
|       | Bolted Connections.....                 | P.1.20 |
|       | Welded Connections.....                 | P.1.21 |
|       | Pin and Hanger Connections.....         | P.1.21 |
|       | Splice Connections.....                 | P.1.22 |
| P.1.6 | Decks.....                              | P.1.23 |
|       | Deck Purpose.....                       | P.1.23 |

|       |  |        |
|-------|--|--------|
|       | Deck Function .....  | P.1.24 |
|       | Deck Materials .....   | P.1.25 |
|       | Timber Decks.....  | P.1.25 |
|       | Concrete Decks .....   | P.1.26 |
|       | Steel Decks.....   | P.1.27 |
|       | Fiber Reinforced Polymer (FRP) Decks .....                           | P.1.28 |
|       | Wearing Surfaces .....   | P.1.28 |
|       | Deck Joints, Drainage, Appurtenances, Signing,<br>and Lighting ..... | P.1.29 |
|       | Deck Joints.....   | P.1.29 |
|       | Drainage Systems.....  | P.1.32 |
|       | Deck Appurtenances .....   | P.1.32 |
|       | Signing.....   | P.1.33 |
|       | Lighting.....  | P.1.34 |
| P.1.7 | Superstructure .....   | P.1.35 |
|       | Superstructure Purpose.....  | P.1.35 |
|       | Superstructure Function.....   | P.1.35 |
|       | Primary Elements .....   | P.1.35 |
|       | Secondary Elements .....   | P.1.36 |
|       | Superstructure Types .....   | P.1.37 |
|       | Beams Bridges .....  | P.1.38 |
|       | Arch Bridges .....   | P.1.43 |
|       | Cable-Supported Bridges .....  | P.1.44 |
|       | Movable Bridges.....   | P.1.45 |
|       | Floating Bridges.....  | P.1.47 |
|       | Culverts.....  | P.1.47 |
| P.1.8 | Bearings .....   | P.1.48 |
|       | Definition.....  | P.1.48 |
|       | Primary Function.....  | P.1.48 |
|       | Basic Elements .....   | P.1.48 |
|       | Bearing Types.....   | P.1.49 |
| P.1.9 | Substructure .....   | P.1.49 |
|       | Substructure Purposes .....  | P.1.49 |
|       | Substructure Function.....   | P.1.50 |
|       | Abutments.....   | P.1.51 |
|       | Piers and Bents.....   | P.1.52 |

# Topic P.1 Bridge Components and Elements

## P.1.1

### Introduction

The bridge inspector should be familiar with the terminology and elementary theory of bridge mechanics and materials. This topic presents the terminology needed by inspectors to properly identify and describe the individual elements that comprise a bridge. First the major components of a bridge are introduced. Then the basic member shapes and connections of the bridge are presented. Finally, the purpose and function of the major bridge components are described in detail.

## P.1.2

### NBIS Structure Length

According to the *Recording and Coding Guide for the Structure Inventory and Appraisal of the Nation's Bridges* the minimum length for a structure carrying traffic loads is 6.1 meters (20 feet). The structure length is measured as shown on Figure P.1.1

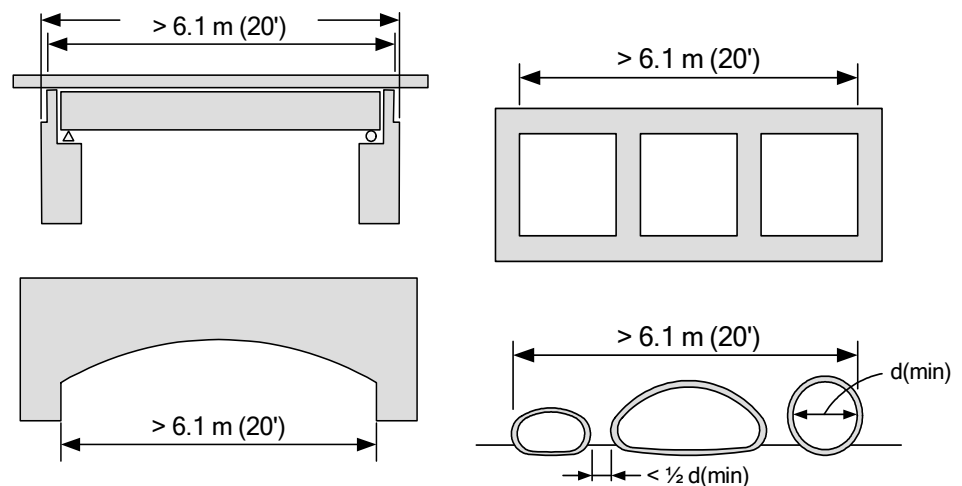

**Figure P.1.1** NBIS Structure Length

23 CFR Part 650.305 Definitions gives the definition of a bridge as it applies to the NBIS regulations. From the NBIS regulations, a bridge is defined as follows: a structure including supports erected over a depression or an obstruction, such as water, highway, or railway, and having a track or passageway for carrying traffic or other moving loads, and having an opening measured along the center of the roadway of more than 20 feet between undercopings of abutments or spring lines of arches, or extreme ends of openings for multiple boxes; it may also include multiple pipes, where the clear distance between openings is less than half of the smaller contiguous opening

## P.1.3

### Major Bridge Components

A thorough and complete bridge inspection is dependent upon the bridge inspector's ability to identify and understand the function of the major bridge components and their elements. Most bridges can be divided into three basic parts or components (see Figure P.1.1A):

- Deck
- Superstructure
- Substructure



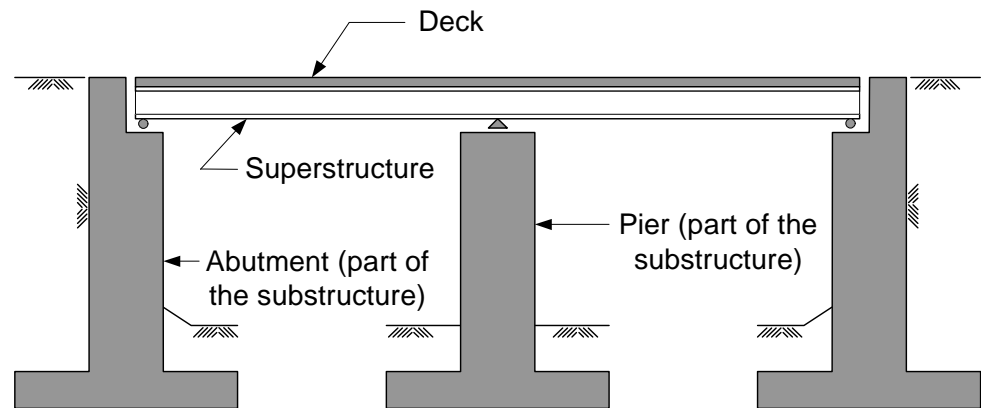

**Figure P.1.1A** Major Bridge Components

## P.1.4

### Basic Member Shapes

The ability to recognize and identify basic member shapes requires an understanding of the timber, concrete, and steel shapes used in the construction of bridges.

Every bridge member is designed to carry a unique combination of tension, compression, and shear. These are considered the three basic kinds of member stresses. Bending loads cause a combination of tension and compression in a member. Shear stresses are caused by transverse forces exerted on a member. As such, certain shapes and materials have distinct characteristics in resisting the applied loads. For a review of bridge loadings and member responses, see Topic P.2.

### Timber Shapes

Basic shapes, properties, gradings, deteriorations, protective systems, and examination of timber are covered in detail in Topic 2.1.

Timber members are found in a variety of shapes (see Figure P.1.2). The sizes of timber members are generally given in nominal dimensions (such as in Figures P.1.2 and P.1.3). However, timber members are generally seasoned and surfaced from the rough sawn condition, making the actual dimension about 13 to 20 mm (1/2 to 3/4 inches) less than the nominal dimension.

The physical properties of timber enable it to resist both tensile and compressive stresses. Therefore, it can function as an axially-loaded or bending member. Timber bridge members are made into three basic shapes:

- Planks
- Beams
- Piles

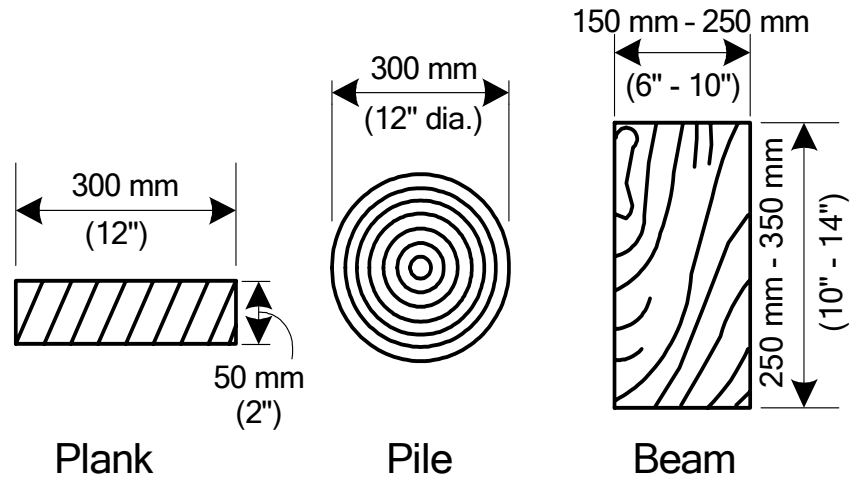

**Figure P.1.2** Timber Shapes

### Planks

Planks are characterized by elongated, rectangular dimensions determined by the intended bridge use. Plank thickness is dependent upon the distance between the supporting points and the magnitude of the vehicle load. A common dimension for timber planks is a 50 mm x 300 mm (2" x 12"), nominal or rough sawn. Dressed lumber dimensions would be 38 mm x 285 mm (1 ½" x 11 ¼") (see Figure P.1.2).

Planks are most often used for bridge decks on bridges carrying light or infrequent truck traffic. While some shapes and materials are relatively new, the use of timber plank decks has existed for centuries. Timber planks are advantageous in that they are economical, lightweight, readily available, and easy to erect.

### Beams

Timber beams have more equal rectangular dimensions than do planks, and they are sometimes square. Common dimensions include 250 mm by 250 mm (10 inches by 10 inches) square timbers, and 150 mm by 350 mm (6 inches by 14 inches) rectangular timbers.

As the differences in the common dimensions of planks and timber beams indicate, beams are larger and heavier than planks and can support heavier loads, as well as span greater distances. As such, timber beams are used in bridge superstructures and substructures to carry bending and axial loads.

Timbers can either be solid sawn or glued-laminated (see Figure P.1.3). Glued-laminated timbers are advantageous in that they can be fabricated from smaller, more readily available pieces. Glued lamination also allows larger rectangular members to be formed without the presence of natural defects such as knots. Glued-laminated timbers are normally manufactured from well-seasoned laminations and display very little shrinkage after they are fabricated.

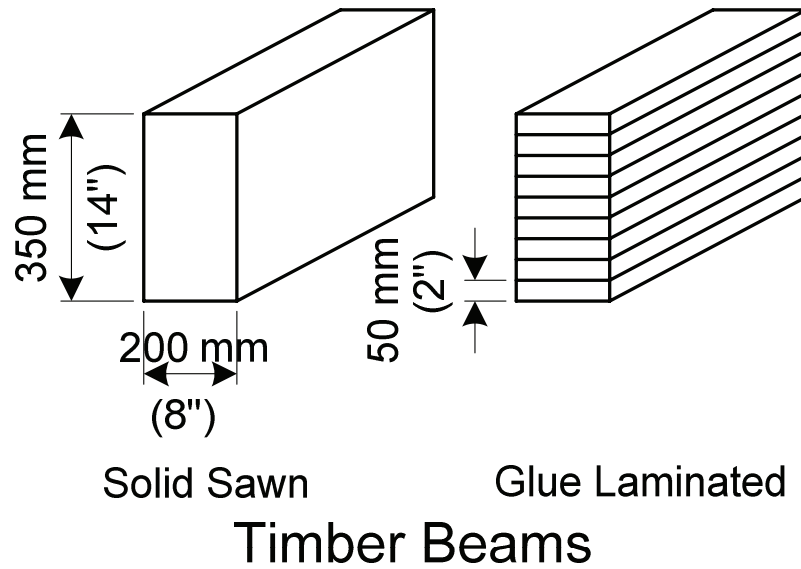

**Figure P.1.3** Timber Beams

### Piles

Timber can also be used for piles. Piles are normally round, slender columns that support the substructure footing or partially form the substructure. Piles may be partially above ground or completely buried.

### Concrete Shapes

Basic ingredients, properties, reinforcement, deterioration, protective systems, and examination of concrete are covered in detail in Topic 2.2.



**Figure P.1.4** Unusual Concrete Shapes

Concrete is a unique material for bridge members because it can be formed into an infinite variety of shapes (see Figure P.1.4). Concrete members are used to carry axial and bending loads. Since bending results in a combination of compressive and tensile stresses, concrete bending members are typically reinforced with either reinforcing steel (producing reinforced concrete) or with prestressing steel (producing prestressed concrete) in order to carry the tensile stresses in the member.

### Cast-in-Place Flexural Shapes

The most common shapes of reinforced concrete members are (see Figure P.1.5):

- Slabs/Decks
- Rectangular beams
- Tee beams
- Channel beams

Bridges utilizing these shapes and mild steel reinforcement have been constructed and were typically cast-in-place (CIP). Many of the designs are obsolete, but the structures remain in service. Concrete members of this type are used for short and medium span bridges.

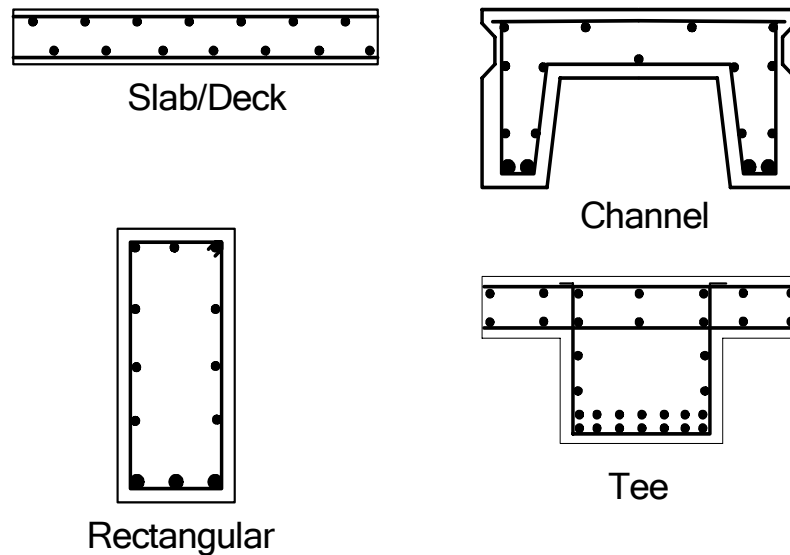

**Figure P.1.5** Reinforced Concrete Shapes

Concrete slabs are used for concrete decks and slab bridges. On concrete decks, the concrete spans the distance between superstructure members and is generally 180 to 230 mm (7 to 9 inches) thick. On slab bridges, the slab spans the distance between piers or abutments, forming an integral deck and superstructure. Slab bridge elements are usually 300 to 600 mm (12 to 24 inches) thick.

Rectangular beams are used for both superstructure and substructure bridge elements. Concrete pier caps are commonly rectangular beams which support the superstructure.

Bridge use for tee beams is generally limited to superstructure elements. Distinguished by a "T" shape, tee beams combine the functions of a rectangular beam and slab to form an integral deck and superstructure.

Bridge use for channel beams is limited to superstructure elements. This particular shape is precast rather than cast-in-place. Channel beams are formed in the shape of a "C" and placed legs down when erected. They function as both superstructure and deck and are typically used for shorter span bridges.

### Precast Flexural Shapes

The most common shapes of prestressed concrete members are (see Figure P.1.6):

- I-beams
- Bulb-tees
- Box beams
- Box girders
- Voided slabs

These shapes are used for superstructure members.

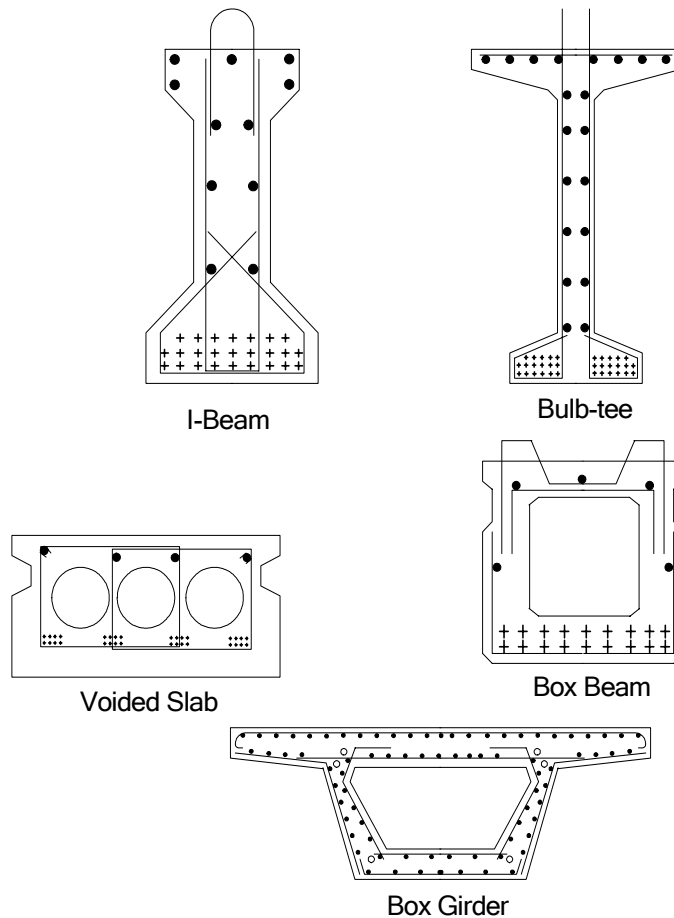
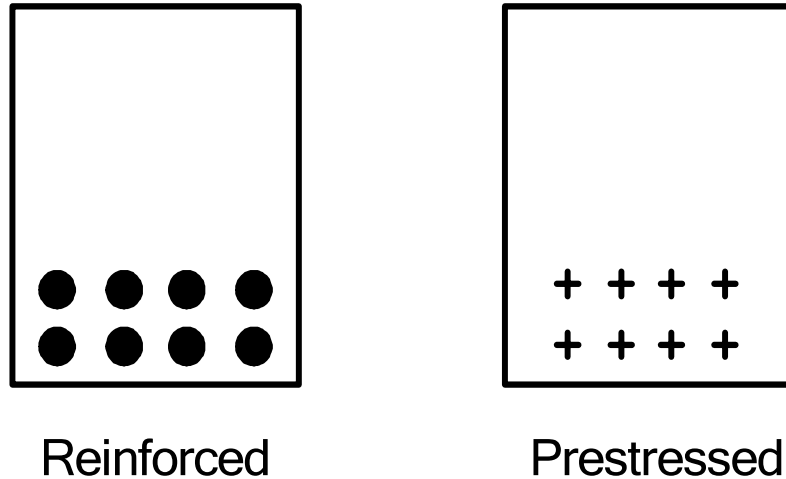

**Figure P.1.6** Prestressed Concrete Shapes

Prestressed concrete beams can be precast at a fabricator's plant using high

compressive strength concrete. Increased material strengths, more efficient shapes, the prestress forces and closely controlled fabrication allow these members to carry greater loads. Therefore, they are capable of spanning greater distances and supporting heavier live loads. Bridges using members of this type and material have been widely used in the United States since World War II.

Prestressed concrete is generally more economical than conventionally reinforced concrete because the prestressing force lowers the neutral axis, putting more of the concrete section into compression. Also, the prestress steel is very high strength, so fewer pounds of steel are needed (see Figure P.1.7).



**Figure P.1.7** Mild Steel Reinforced Concrete vs. Precast Prestressed Concrete

I-beams, distinguished by their "I" shape, function as superstructure members and support the deck. This type of beam can be used for spans as long as 46 m (150 feet).

Bulb-tee beams are distinguished by their "T" shapes, with a bulb-shaped section (similar to the bottom flange of an I-beam) at the bottom of the vertical leg of the tee. This type of beam can be used for spans as long as 55 m (180 feet).

Box beams, distinguished by a square or rectangular shape, usually have a beam depth greater than 430 mm (17 inches). Box beams can be adjacent or spread, and they are typically used for short and medium span bridges.

Box girders, distinguished by their trapezoidal or rectangular box shapes, function as both deck and superstructure. Box girders are used for long span or curved bridges and can be precast and erected in segments or cast in place.

Voided slabs, distinguished by their rectangular shape and their interior voids, are generally precast units supported by the substructure. The interior voids are used to reduce the dead load. Voided slabs can be used for spans of 9 to 24 m (30 to 80 feet).

### **Axially-Loaded Compression Members**

Concrete axially-loaded compression members are used in bridges in the form of:

- Columns
- Arches
- Piles

Because these members also carry varying bending forces, they contain steel reinforcement.

Columns are straight members which can carry axial load, horizontal load, and bending and are used as substructure elements. Columns are commonly square, rectangular, or round.

An arch can be thought of as a curved column and is commonly used as a superstructure element. Concrete superstructure arches are generally square or rectangular in cross section.

Piles are slender columns that support the substructure footing or partially form the substructure. Piles may be partially above ground but are usually completely buried (see Figure P.1.8).



**Figure P.1.8** Concrete Pile Bent

### **Iron Shapes**

Iron was used predominately as a bridge material between 1850 and 1900. Stronger and more fire resistant than wood, iron was widely used to carry the expanding railroad system during this period.

There are two types of iron members: cast iron and wrought iron. Cast iron is formed by casting, whereas wrought iron is formed by forging or rolling the iron into the desired form.

### **Cast Iron**

Historically, cast iron preceded wrought iron as a bridge material. The method of casting molten iron to form a desired shape was more direct than that of wrought iron.

Casting allowed iron to be formed into almost any shape. However, because of cast iron's brittleness and low tensile strength, bridge members of cast iron were best used to carry axial compression loads. Therefore, cast iron members were usually cylindrical or box-shaped to efficiently resist axial loads.

### **Wrought Iron**

In the late 1800's, wrought iron virtually replaced the use of cast iron. The two primary reasons for this were that wrought iron was better suited to carry tensile loads and advances in rolling technology made wrought iron shapes easier to obtain and more economical to use. Advances in technology made it possible to form a variety of shapes by rolling, including:

- Rods and wire
- Bars
- Plates
- Angles
- Channels
- Beams



## Steel Shapes

Steel bridge members began to be used in the United States in the late 1800's and, by 1900, had virtually replaced iron as a bridge material. The replacement of iron by steel was the result of advances in steel making (see Figure P.1.9). These advances yielded a steel material that surpassed iron in both strength and elasticity. Steel could carry heavier loads and better withstand the shock and vibration of ever-increasing live loads. Since the early 1900's, the quality of steel has continued to improve. Stronger and more ductile A36, A572, and A588 steels have replaced early grades of steel, such as A7.

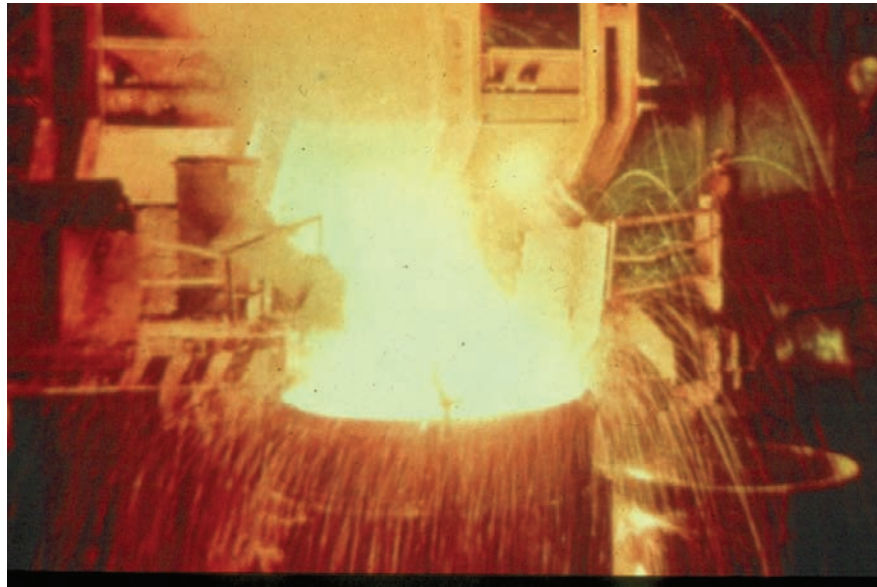

**Figure P.1.9** Steel Making Operation

Due to their strength, steel bridge members are used to carry axial forces as well as bending forces. Steel shapes are generally either rolled or built-up.

### Rolled Shapes

Rolled steel shapes commonly used on bridges include (see Figure P.1.10):

- Bars and plates
- Angles
- Channels
- S Beams
- W Beams

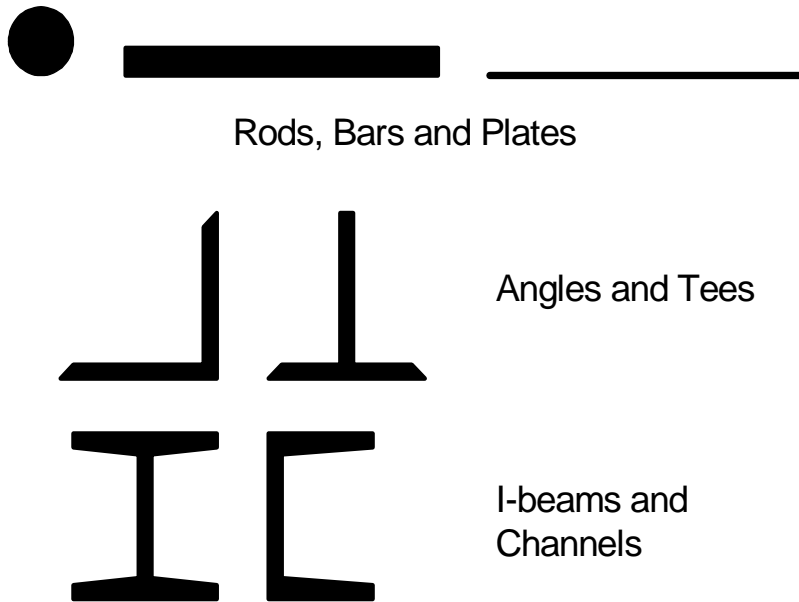

**Figure P.1.10** Common Rolled Steel Shapes

The standard weights and dimensions of these shapes can be found in the American Institute of Steel Construction (AISC) *Manual of Steel Construction*.

Bars and plates are formed into flat pieces of steel. Bars are normally considered to be up to 200 mm (8 inches) in width. Common examples of bars include lacing bars on a truss and steel eyebars. Plates are designated as flat plates if they are over 200 mm (8 inches) in width. A common example of a plate is the gusset plate on a truss. Bars and plates are dimensioned as follows: width x thickness x length. Examples of bar and plate dimensions include:

- Lacing bar: 50 mm x 10 mm x 0.4 m (2" x 3/8" x 1'-3")
- Gusset plate: 530 mm x 12 mm x 1.3 m (21" x 1/2" x 4'-4")

Angles are “L”-shaped members, the sides of which are called “legs”. Each angle has two legs, and the width of the legs can either be equal or unequal. When dimensioning angles, the two leg widths are given first, followed by the thickness and the length. Examples of angle dimensions include:

- L 102 mm x 102 mm x 6.4 mm x 965 mm (L 4" x 4" x 1/4" x 3'-2")
- 2L's 127 mm x 76 mm x 9.5 mm x 330 mm (2L's 5" x 3" x 3/8" x 1'-1")

Angles range in size from 25 mm x 25 mm x 6 mm to 200 mm x 200 mm x 28 mm (1"x1"x1/4" to 8"x8"x1-1/8"). Angles range in weight from less than 14.6 N/m (1 pound per foot) to almost 880 N/m (60 pounds per foot).

Angles, bars, and plates are commonly connected to form bracing members (see Figure P.1.11).



**Figure P.1.11** Bracing Members Made from Angles, Bars, and Plates

Channels are squared-off "C"-shaped members and are used as diaphragms, struts, or other built-up members. The top and bottom parts of a channel are called the flanges. Channels are dimensioned by the depth (the distance between outside edges of the flanges) in mm or inches, the weight in kg per m or pounds per foot, and the length in mm or inches. Examples of channel dimensions include:

- C 230 x 22 x 2895 mm (C 9 x 15 x 9'-6")
- C 310 x 31 x 3416 mm (C 12 x 20.7 x 11'-2-1/2")

When measuring a channel, it is not possible for the inspector to know how much the channel section weighs. In order to determine the weight, the inspector must record the flange width and the web depth. From this information, the inspector can then determine the true channel designation through the use of reference books.

Standard channels range in depth from 75 mm to 380 mm (3 inches to 15 inches), and weights range from less than 73 N/m (5 pounds per foot) to 730 N/m (50 pounds per foot). Nonstandard sections (called miscellaneous channels or MC) are rolled to depths of up to 600 mm (24 inches), weighing up to 845 N/m (60 pounds per foot).

Beams are "I"-shaped sections used as main load-carrying members. The load-carrying capacity generally increases as the member size increases. The early days of the iron and steel industry saw the various manufacturers rolling beams to their own standards. It was not until 1896 that beam weights and dimensions were standardized when the Association of American Steel Manufacturers adopted the American Standard beam. Because of this, I-beams are referred to by many designations, depending on their dimensions and the time period in which the particular shape was rolled. Today all I-beams are dimensioned according to their depth, weight, and length.

Examples of beam dimensions include:

- S380x74 (S15x50) - an American Standard (hence the “S”) beam with a depth of 380 mm (15 inches) and a weight of 74 N/m (50 pounds per foot)
- W460x113 (W18x76) - a wide (W) flange beam with a depth of 460 mm (18 inches) and a weight of 113 N/m (76 pounds per foot)

Some of the more common designations for rolled I-beams are:

- S = American Standard beam
- W = Wide flange beam
- WF = Wide flange beam
- CB = Carnegie beam
- M = Miscellaneous beam
- HP = H-pile

When measuring an I-beam, the inspector needs to measure the depth, the flange width and thickness, and the web thickness (if possible). With this information, the inspector can then determine the beam designation from reference books.

These beams normally range in depth from 75 to 900 mm (3 to 36 inches) and range in weight from 90 to over 4380 N/m (6 to over 300 pounds per foot). There are some steel mills that can roll beams up to 1120 mm (44 inches) deep.

### **Built-up Shapes**

Built-up shapes offer a great deal of flexibility in designing member shapes. As such, they allow the bridge engineer to customize the members to their use. Built-up shapes are fabricated by either riveting or welding techniques.

The practice of riveting steel shapes began in the 1800’s and continued through the 1950’s. Typical riveted shapes include girders and boxes.

Riveted girders are large I-beam members fabricated from plates and angles. These girders were fabricated when the largest rolled beams were still not large enough as required by design (see Figure P.1.12).

Riveted boxes are large rectangular shapes fabricated from plates, angles, or channels. These boxes are used for cross-girders, truss chord members, and substructure members (see Figure P.1.13).

As technology improved, the need for riveting was replaced by high strength bolts and welding. Popular since the early 1960’s, welded steel shapes also include girders and boxes.

Welded girders are large I-beam members fabricated from plates. They are referred to as welded plate girders and have replaced the riveted girder (see Figure P.1.14).

Welded boxes are large, rectangular-shaped members fabricated from plates.

Welded boxes are commonly used for superstructure girders, truss members, and cross girders. Welded box shapes have replaced riveted box shapes (see Figure P.1.15).

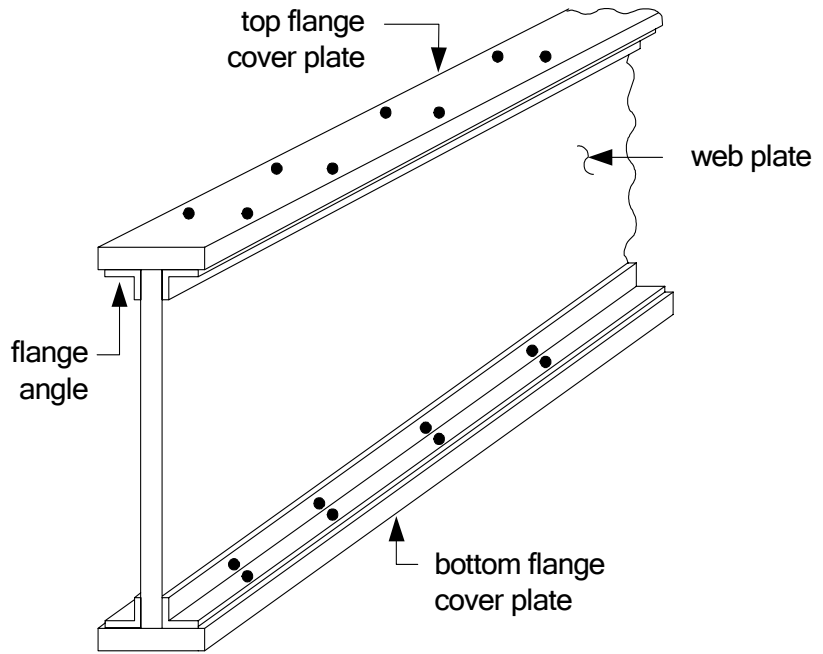

Figure P.1.12 Riveted Plate Girder

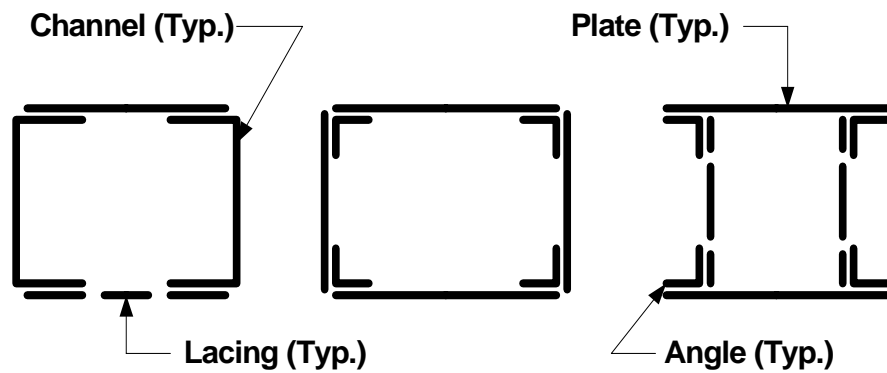
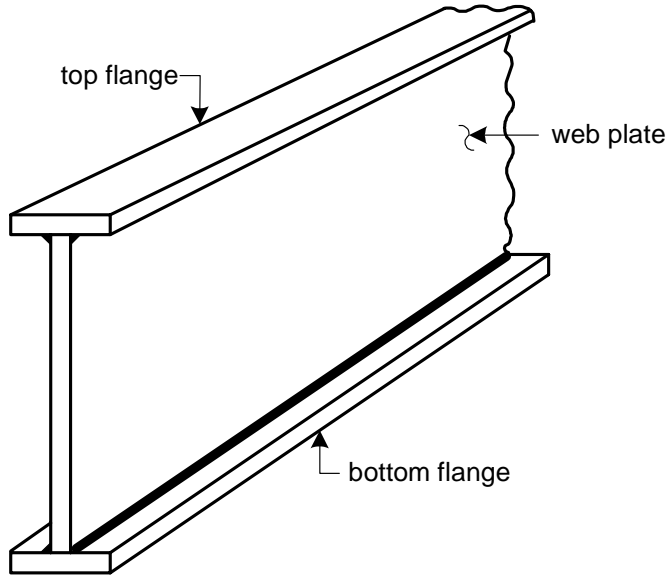
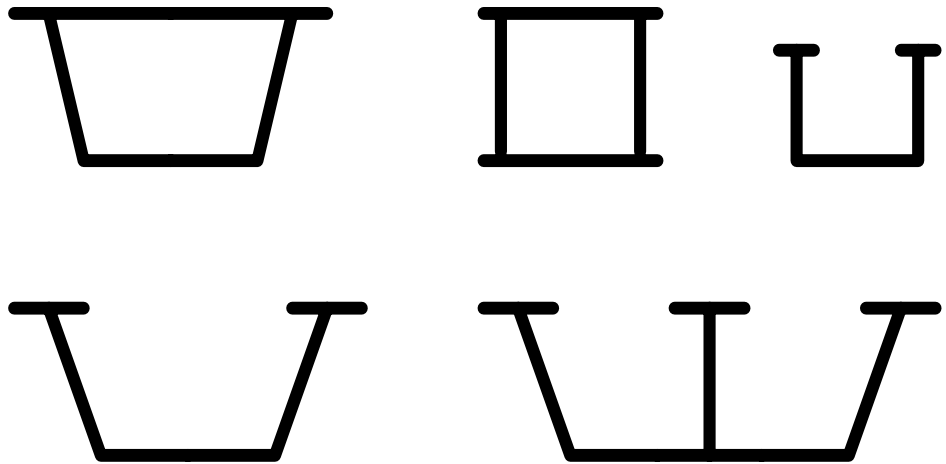

Figure P.1.13 Riveted Box Shapes



**Figure P.1.14** Welded I-Beam



**Figure P.1.15** Welded Box Shapes

### Cables

Steel cables are tension members and are used in suspension, tied-arch, and cable-stayed bridges. They are used as main cables and hangers of these bridge types (see Figure P.1.16). Refer to Topic 12.1 for a more detailed description of cable-supported bridges.



**Figure P.1.16** Cable-Supported Bridges

## **P.1.5**

---

### **Connections**

Rolled and built-up steel shapes are used to make stringers, floor beams, girders, and truss members. These members require structural joints, or connections, to transfer loads between members. There are several different types of bridge member connections:

- Pin connections
- Riveted connections
- Bolted connections
- Welded connections

- Pin and hanger connections
- Splice connections

### Pin Connections

Pins are cylindrical beams produced by forging, casting, or cold-rolling. The pin sizes and configurations are as follows (see Figure P.1.17):

- A small pin, 32 to 100 mm (1-1/4 to 4 inches) in diameter, is usually made with a cotter pin hole at one or both ends
- A medium pin, up to 250 mm (10 inches) in diameter, usually has threaded end projections for recessed retainer nuts
- A large pin, over 250 mm (10 inches) in diameter, is held in place by a recessed cap at each end and is secured by a bolt passing completely through the caps and pin

Pins are often surrounded by a protective sleeve, which may also act as a spacer to separate members. Pin connections are commonly used in eyebar trusses, hinged arches, pin and hanger assemblies, and bearing supports (see Figure P.1.18).

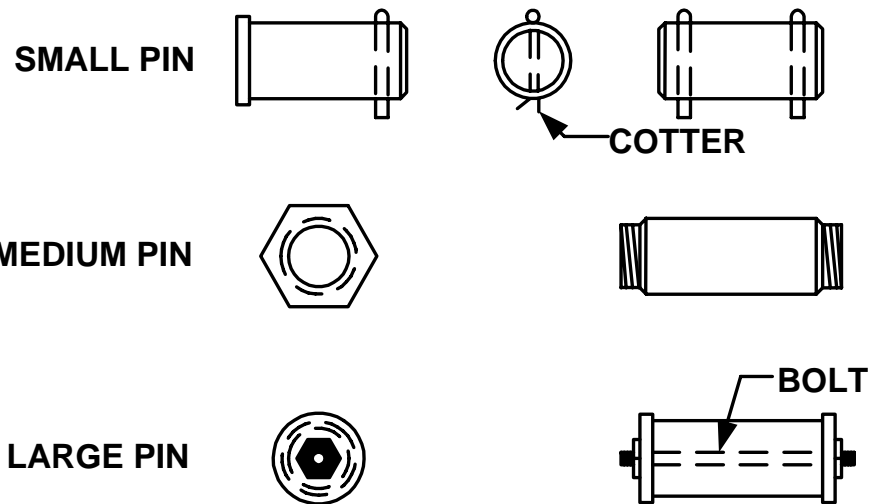

Figure P.1.17 Sizes of Bridge Pins





**Figure P.1.18** Pin-Connected Truss Members

The major advantages of using pin connection details are the design simplicity and the ability for free end rotation. The design simplicity afforded by pin connections reduces the amount and complexity of design calculations. By allowing for free end rotation, pin connections reduce the level of stress in the member.

The major disadvantages of pin connection details are the result of vibration, pin wear, unequal eyebar tension, unseen corrosion, and poor inspectability. Vibrations increase with pin connections because they allow more movement than more rigid types of connections. As a result of increased vibration, moving parts are subject to wear.

Pin connections are used both in trusses and at expansion joints. Both truss and girder suspended spans or cantilever joints that permit expansion are susceptible to freezing or fixity of the pinned joints. This results in changes in the structure and undesirable stresses when axially-loaded members become bending members.

Some pins connect multiple eyebars. Since the eyebars may have different lengths, they may experience different levels of tension. In addition, because parts of the pin surface are hidden from view by the eyebars, links, or connected parts, an alternate method of completely inspecting the pin must be used (e.g., ultrasonic or pin removal).

### **Riveted Connections**

The rivet was the primary fastener used in the early days of iron and steel bridges. The use of high strength bolts replaced rivets by the early 1960's.

The standard head is called a high-button or acorn-head rivet. Flat-head and countersunk-head rivets were also used in areas of limited clearance, such as an eyebar pin connection (see Figure P.1.19).

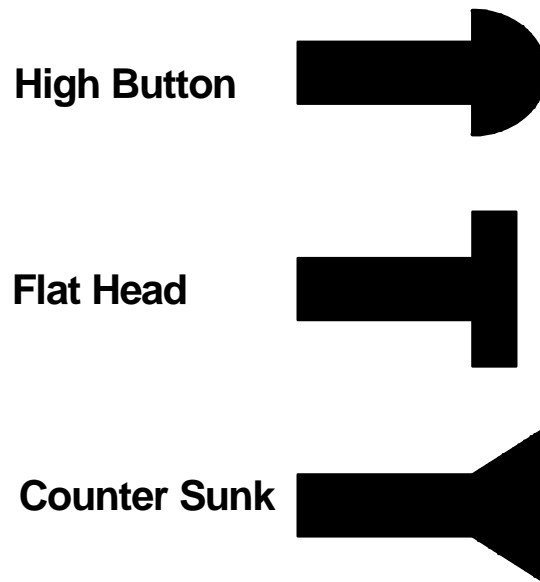

**Figure P.1.19** Types of Rivet Heads

There are two grades of rivets typically found on bridges:

- ASTM A502 Grade 1 (formerly ASTM A141) low carbon steel
- ASTM A502 Grade 2 (formerly ASTM A195) high strength steel

The rivet sizes most often used on bridges were 19, 23, or 25 mm (3/4, 7/8, or 1-inch) shank diameters. Rivet holes were generally 2 mm (1/16-inch) larger than the rivet shank. While the hot rivet was being driven, the shank would increase slightly, filling the hole. As the rivet cooled, it would shrink in length, clamping together the connected elements.

When the inspector can feel vibration on one head of the rivet while hitting the other rivet head with a hammer, this generally indicates that the rivet is loose. This method may not work with sheared rivets clamped between several plates.

## Bolted Connections

Research into the use of high strength bolts began in 1947. The first specifications for the use of bolts were subsequently published in 1951. The economic and structural advantages of bolts over rivets led to their rapid use by bridge engineers. Bridges constructed in the late 1950's may have a combination of riveted (shop) and bolted (field) connections (see Figure P.1.20).

Structural bolts consist of three basic material designations:

- ASTM A307 low carbon steel
- ASTM A325M (ASTM A325 (AASHTO M 164)) high strength steel
- ASTM A490M (ASTM A490 (AASHTO M 253)) high strength alloy steel

For further information on the bolts listed above or any other material properties visit the American Society for Testing and Materials International website at: [www.astm.org](http://www.astm.org) .

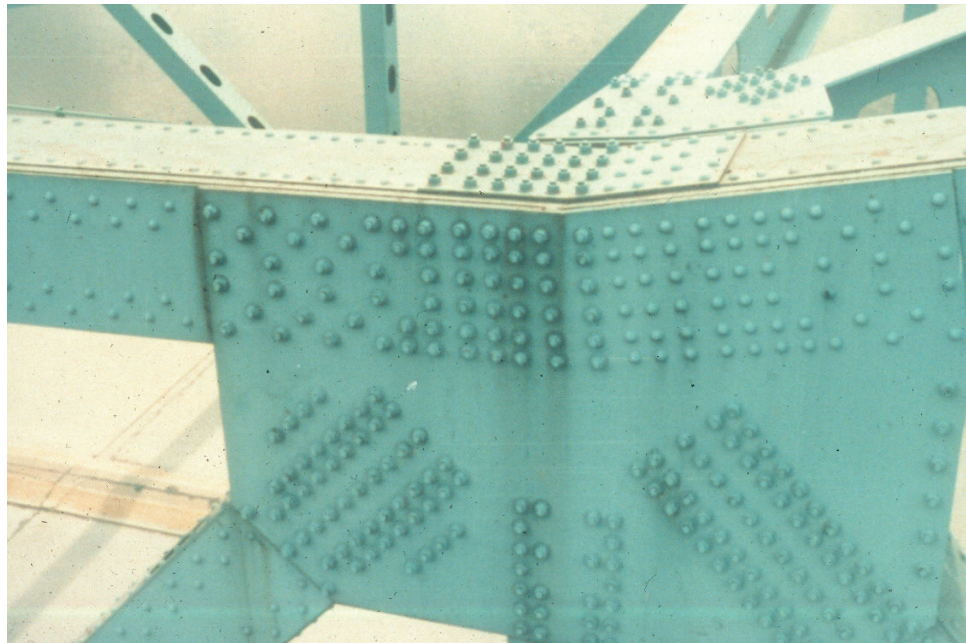

**Figure P.1.20** Shop Rivets and Field Bolts

The most commonly used bolts on bridges are 19, 23, and 25 mm (3/4, 7/8, and 1-inch) in diameter. Larger bolts are often used to anchor the bearings. Bolt holes are typically 1/16-inch larger than the bolt. However, oversized and slotted holes are also permissible.

The strength of high strength bolts is measured in tension. However, the inspection of high strength bolts on bridges involves many variables. Although the installation inspection of new high strength bolts often requires the use of a torque wrench, this method does not have any merit when inspecting high strength bolts on in-service bridges. The torque is dependent on factors such as bolt diameter, bolt length, connection design (bearing or friction), use of washers, paint and coatings, parallelism of connected parts, dirt, rust, and corrosion.

The inspector must be cautioned that standard tables and formulas relating tension to torque are no longer considered valid.

Simple techniques, such as looking and feeling for loose bolts, are the most common methods used by inspectors when inspecting bolts.

### **Welded Connections**

Pins, rivets, and bolts are examples of mechanical fasteners forming non-rigid joints. A welded connection is not mechanical but rather is rigid one-piece construction. A properly welded joint, in which two pieces are fused together, is as strong as the joined materials.

Similar to mechanical fasteners, welds are used to make structural connections between members and also to connect elements of a built-up member. Welds have also been used in the fabrication and erection of bridges as a way to temporarily hold pieces together prior to field riveting, bolting, or welding. Small temporary erection welds, known as tack welds, can cause serious fatigue problems to certain bridge members (see Figure P.1.21). Fatigue and fracture of steel bridge members are discussed in detail in Topic 8.1 (refer to 8.1.3 for factors affecting fatigue crack initiation). Welding is also used as a means of sealing joints and seams from moisture.



**Figure P.1.21** Close-up of Tack Weld on a Riveted Built-up Truss Member

The first specification for using welds on bridges appeared in 1936. Welding eventually replaced rivets for fabricating built-up members. Welded plate girders, hollow box-like truss members, and shear connectors for composite decks are just a few of the advances attributed to welding technology.

Welds need to be carefully inspected for cracks or signs of cracks (e.g., broken paint or rust stains) in both the welds and the adjoining base metal elements.

### **Pin and Hanger Connections**

A pin and hanger connection is a type of hinge consisting of two pins and a hanger. Pin and hanger connections are used in an articulated (continuous bridge with hinges) or a suspended span configuration. The location of the connection varies depending on the type of bridge. In I-beam bridges, a hanger is located on



either side of the webs (see Figure P.1.22). In suspended span truss bridges, each connection has a hanger which is similar in shape to the other truss members (with the exception of the pinned ends).

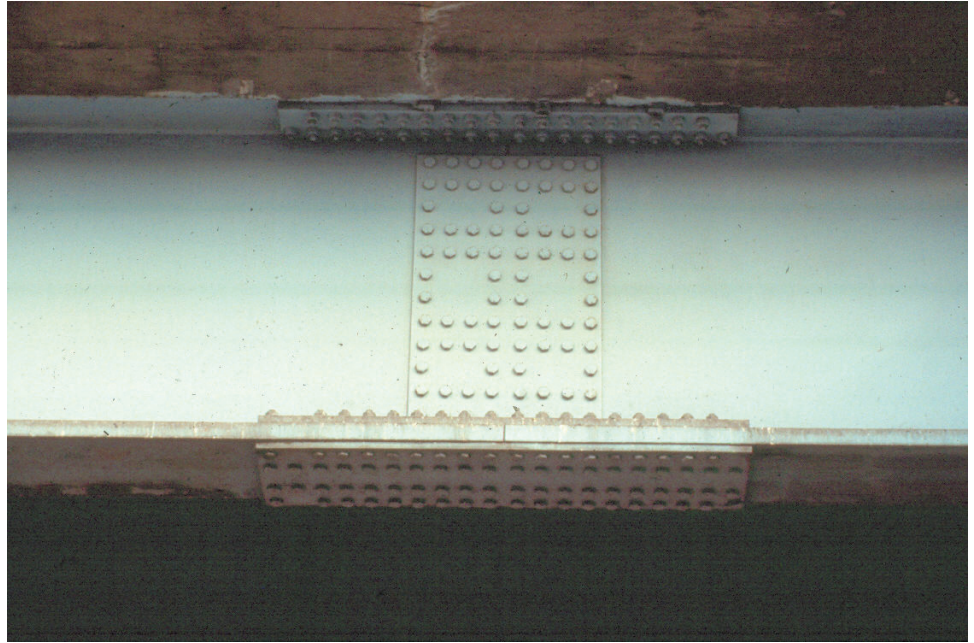

**Figure P.1.22** Pin and Hanger Connection

Pin and hanger connections must be carefully inspected for signs of wear and corrosion. A potential problem can occur if corrosion of the pin and hanger causes the connection to "freeze," inhibiting free rotation. This condition does not allow the pin to rotate and results in additional stresses in the pin and hanger and adjacent girder. The failure of a pin and hanger connection can cause a partial or complete failure of the bridge.

### **Splice Connections**

A splice connection is the joining of two sections of the same member, either in the fabrication shop or in the field. This type of connection can be made using rivets, bolts, or welds. Bolted splices are common in multi-beam superstructures due to the limited allowable shipping lengths (see Figure P.1.23). Welded flange splices are common in large welded plate girders as a means of fabricating the most economical section.



**Figure P.1.23** Bolted Field Splice

## **P.1.6**

### **Decks**

The deck is that component of a bridge to which the live load is directly applied. Refer to Section 5 for a detailed explanation on the inspection and evaluation of decks.

#### **Deck Purpose**

The purpose of the deck is to provide a smooth and safe riding surface for the traffic utilizing the bridge (see Figure P.1.24).



**Figure P.1.24** Bridge Deck with a Smooth Riding Surface

## Deck Function

The function of the deck is to transfer the live load and dead load of the deck to other bridge components. In most bridges, the deck distributes the live load to the superstructure (see Figure P.1.25). However, on some bridges (e.g., a concrete slab bridge), the deck and superstructure are one unit which distributes the live load directly to the bridge supports.



**Figure P.1.25** Underside View of a Bridge Deck

Decks function in one of two ways:

- Composite decks - act together with their supporting members and increase superstructure capacity (see Figures P.1.26 and P.1.27)
- Non-composite decks - are not integral with their supporting members and do not contribute to structural capacity of the superstructure

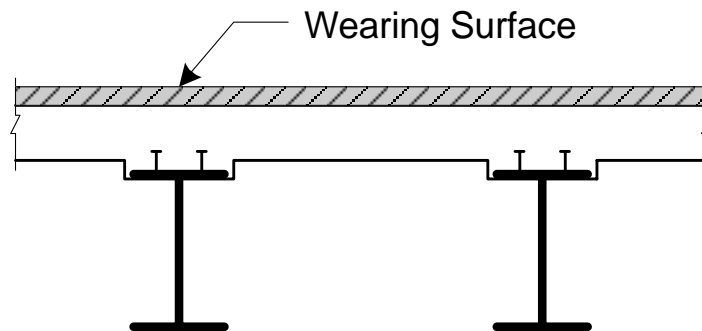

**Figure P.1.26** Composite Deck and Steel Superstructure





**Figure P.1.27** Shear Studs on Top Flange of Girder (before Concrete Deck is Placed)

## Deck Materials

There are three common materials used in the construction of bridge decks:

- Timber
- Concrete
- Steel

### Timber Decks

Timber decks are normally referred to as decking or timber flooring, and the term is limited to the roadway portion which receives vehicular loads. Refer to Topic 5.1 for a detailed explanation on the inspection and evaluation of timber decks.

Five basic types of timber decks are:

- Plank deck (see Figure P.1.28)
- Nailed laminated deck
- Glued-laminated deck planks
- Stressed-laminated decks
- Structural composite lumber decks





**Figure P.1.28** Plank Deck

### **Concrete Decks**

Concrete permits casting in various shapes and sizes and has provided the bridge designer and the bridge builder with a variety of construction methods. Because concrete is weak in tension, it is used together with reinforcement to resist the tensile stresses (see Figure P.1.29). Refer to Topic 5.2 for a detailed explanation on the inspection and evaluation of concrete decks.

There are several common types of concrete decks:

- Reinforced cast-in-place (CIP) - removable or stay-in-place forms
- Precast
- Precast, prestressed deck panels
- Precast prestressed deck panels with cast-in-place topping



**Figure P.1.29** Concrete Deck

### **Steel Decks**

Steel decks are decks composed of either solid steel plate or steel grids (see Figure P.1.30). Refer to Topic 5.3 for a detailed explanation on the inspection and evaluation of steel decks.

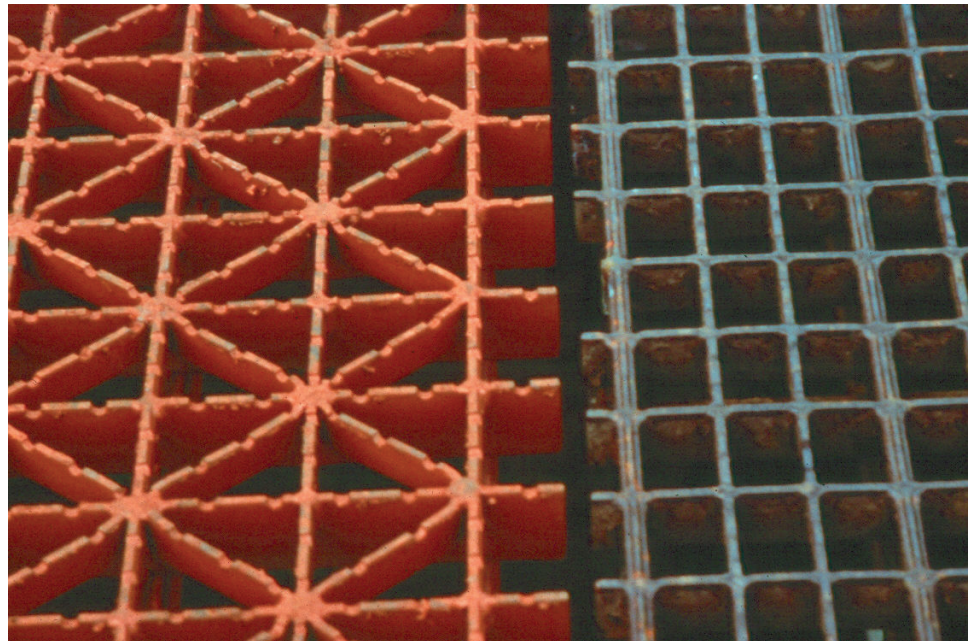

**Figure P.1.30** Steel Grid Deck



There are four common types of steel decks:

- Corrugated steel flooring
- Orthotropic deck
- Grid Deck - open, filled, or partially filled
- Buckle plate deck (still exist on some older bridges but are no longer used)

### **Fiber Reinforced Polymer (FRP) Decks**

With the rise of technological development, innovative material such as carbon-fiber-reinforced polymer (FRP) bridge decking has begun replacing existing highway bridge decks. Though FRP material is more expensive than conventional bridge materials such as concrete, it has several other advantages. These include lighter weight for efficient transport, better resistance to earthquakes, and easier installation. FRP bridge decking is also not affected by water or de-icing salts, which corrode steel and deteriorate concrete (see Figure P.1.31).



**Figure P.1.31** Fiber Reinforced Polymer (FRP) Deck

### **Wearing Surfaces**

Constant exposure to the elements makes weathering a significant cause of deck deterioration. In addition, vehicular traffic produces damaging effects on the deck surface. For these reasons, a wearing surface is often applied to the surface of the deck. The wearing surface is the topmost layer of material applied upon the deck to provide a smooth riding surface and to protect the deck from the effects of traffic and weathering.

A timber deck may have one of the following wearing surfaces:

- Timber planks
- Asphalt/Bituminous

Concrete decks may have wearing surfaces of:

- Concrete
- Latex modified concrete (LMC)
- Low slump dense concrete (LSDC)
- Asphalt or bituminous (see Figure P.1.32)
- Epoxy overlay with broadcast aggregate



**Figure P.1.32** Asphalt Wearing Surface on a Concrete Deck

Steel decks may have wearing or riding surfaces of:

- Serrated steel
- Concrete
- Asphalt

### **Deck Joints, Drainage, Appurtenances, Signing and Lighting**

#### **Deck Joints**

The primary function of a deck joint is to accommodate the expansion, contraction, and rotation of the superstructure. The joint must also provide a smooth transition from an approach roadway to a bridge deck, or between adjoining segments of bridge deck.

There are two major categories of deck joints:

- Open joints
- Closed joints

#### Open Joints

Open joints allow water and debris to pass through them. There are two types of unsealed joints:

- Formed joints
- Finger plate joints (see Figure P.1.33)



**Figure P.1.33** Top View of a Finger Plate Joint

#### Closed Joints

Closed joints are designed so water and debris do not pass through them. There are seven types of closed joints:

- Poured joint seal
- Compression seal (see Figure P.1.34)



- Cellular seal (closed cell foam)
- Sliding plate joint
- Prefabricated elastomeric seal – plank, sheet, or strip seal (see Figure P.1.35)
- Modular elastomeric seal
- Asphaltic expansion joint



**Figure P.1.34** Top View of an Armored Compression Seal in Place

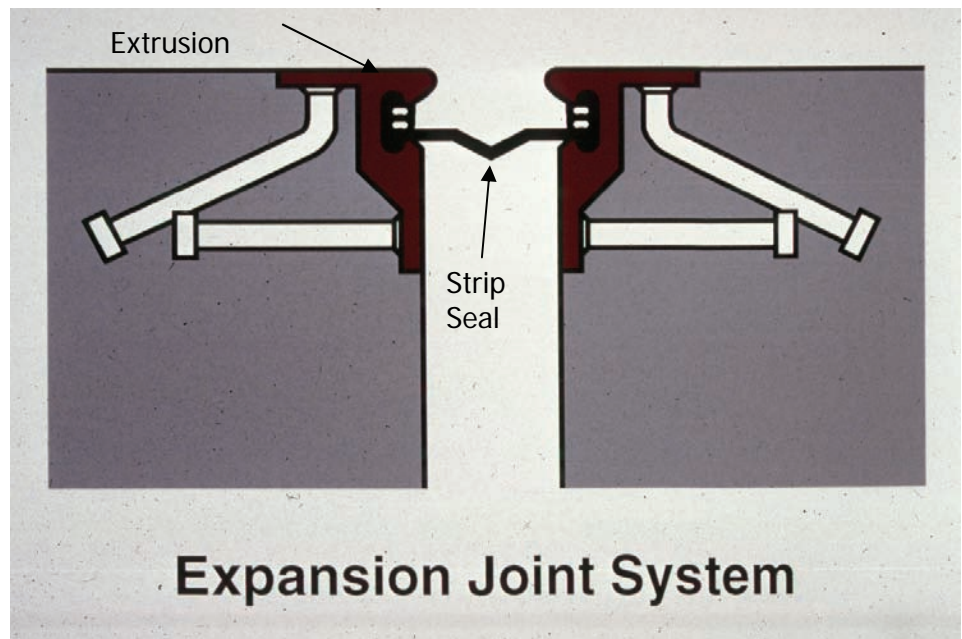

**Figure P.1.35** Strip Seal

## **Drainage Systems**

The primary function of a drainage system is to remove water from the bridge deck, from under unsealed deck joints and from behind abutments and wingwalls.

### **Deck Drainage System**

A deck drainage system has the following components:

- Deck drains
- Outlet pipes - to lead water away from drain
- Downspouts pipes - to transport runoff to storm sewers
- Cleanout plugs - for maintenance

### **Joint Drainage System**

A joint drainage system is typically a separate gutter or trough used to collect water passing through a finger plate or sliding plate joint.

Combining all these drainage components forms a complete deck drainage system.

### **Substructure Drainage Systems**

Substructure drainage allows the fill material behind an abutment or wingwall to drain any accumulated water.

Substructure drainage is accomplished with weep holes or substructure drain pipes.

## **Deck Appurtenances**

The proper and effective use of deck appurtenances minimizes hazards for traffic on the highways as well as waterways beneath the bridge.

### **Bridge Barriers**

Bridge barriers can be broken down into two categories:

- Bridge railing - to guide, contain, and redirect errant vehicles
- Pedestrian railing - to protect pedestrians

Examples of railing include:

- Timber plank rail
- Steel angles and bars
- Concrete pigeon hole parapet
- Combination bridge-pedestrian aluminum or steel railing
- New Jersey barrier - a very common concrete barrier (see Figure P.1.36)



**Figure P.1.36** New Jersey Barrier

#### Sidewalks and Curbs

The function of sidewalks and curbs is to provide access to and maintain safety for pedestrians. Curbs serve to lessen the chance of vehicles crossing onto the sidewalk and endangering pedestrians.

#### Signing

Signing serves to inform the motorist about bridge or roadway conditions that may be hazardous.

Several signs likely to be encountered are:

- Weight limit (see Figure P.1.37)
- Speed traffic marker
- Vertical clearance
- Lateral clearance
- Narrow underpass





**Figure P.1.37** Weight Limit Sign

### **Lighting**

Types of lighting that may be encountered on a bridge include the following (see Figure P.1.38):

- Highway lighting
- Traffic control lights
- Aerial obstruction lights
- Navigation lights
- Signing lights



**Figure P.1.38** Bridge Lighting

Refer to Topic 5.4 for a more detailed explanation on joints, drainage, signing, and lighting of bridge decks. Refer to Topic 5.5 for a more detailed explanation on safety features and barriers of bridge decks.

## **P.1.7**

---

### **Superstructure**

**Superstructure Purpose** The basic purpose of the superstructure is to carry loads from the deck across the span and to the bridge supports. The superstructure is that component of the bridge which supports the deck or riding surface of the bridge, as well as the loads applied to the deck.

**Superstructure Function** The function of the superstructure is to transmit loads. Bridges are named for their type of superstructure. Superstructures may be characterized with regard to their function (i.e., how they transmit loads to the substructure). Loads may be transmitted through tension, compression, bending, or a combination of these three.

There are three common materials used in the construction of bridge superstructures:

- Timber
- Concrete
- Steel

### **Primary Elements**

Most superstructures are made up of two basic elements:

- Floor system - Receives traffic loads from the deck and distributes them to the main supporting elements (see Figure P.1.39)

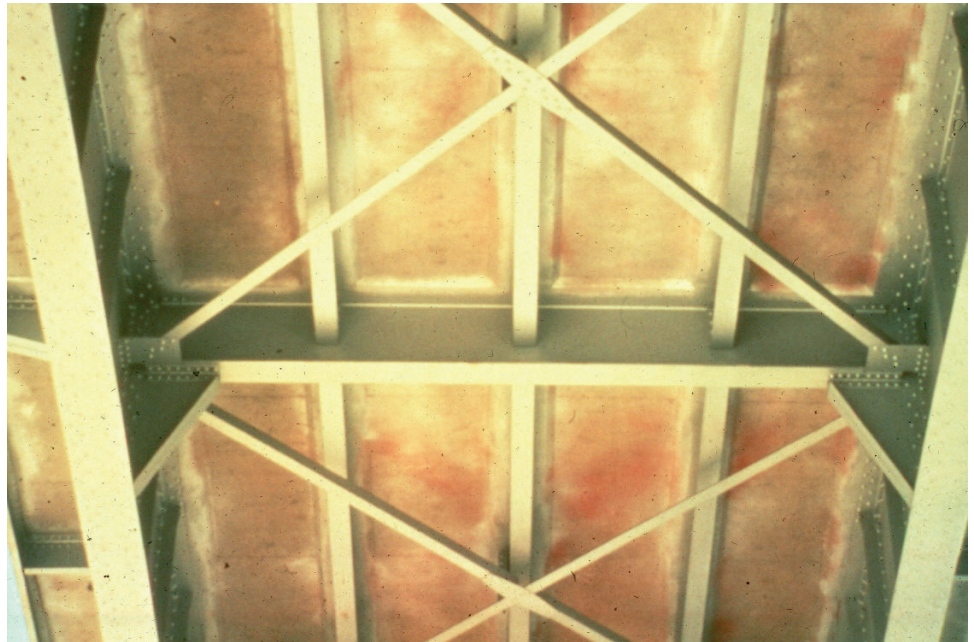

**Figure P.1.39** Floor System



- Main supporting elements - Transfer all loads to the substructure units (see Figure P.1.40)



**Figure P.1.40** Main Supporting Elements of Deck Arch

### Secondary Elements

Secondary elements are elements which do not normally carry traffic loads directly. Typical secondary elements are:

- Diaphragms (see Figure P.1.41)
- Cross or X-bracing (see Figure P.1.42)
- Lateral bracing (see Figure P.1.43)
- Sway-portal bracing (see Figure P.1.43)



**Figure P.1.41** Diaphragms

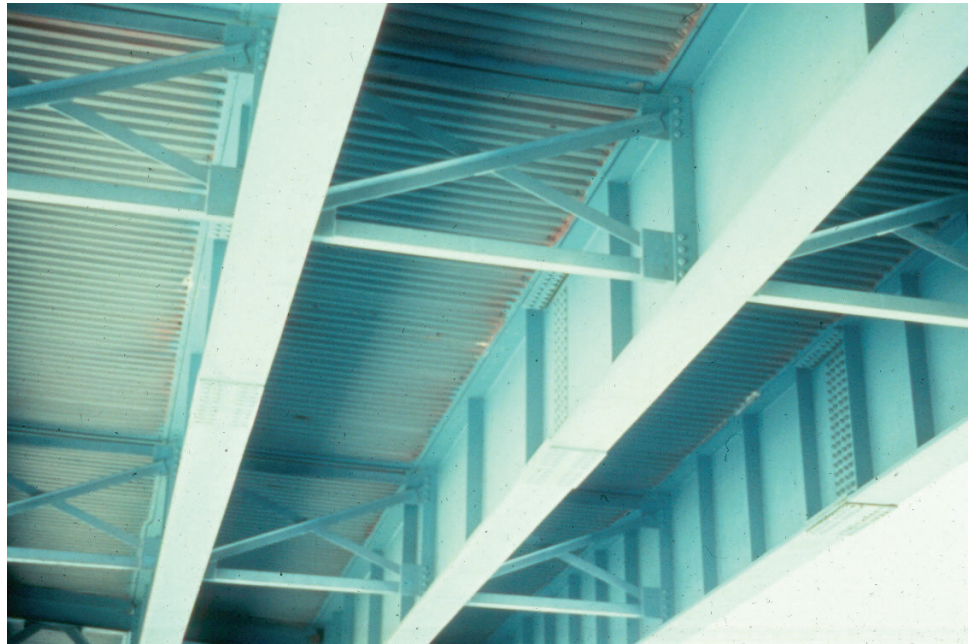

**Figure P.1.42** Cross or X-Bracing



**Figure P.1.43** Top Lateral Bracing and Sway Bracing

**Superstructure Types**

There are three basic types of bridges (see Figure P.1.44):

- Beam
- Arch
- Cable-supported



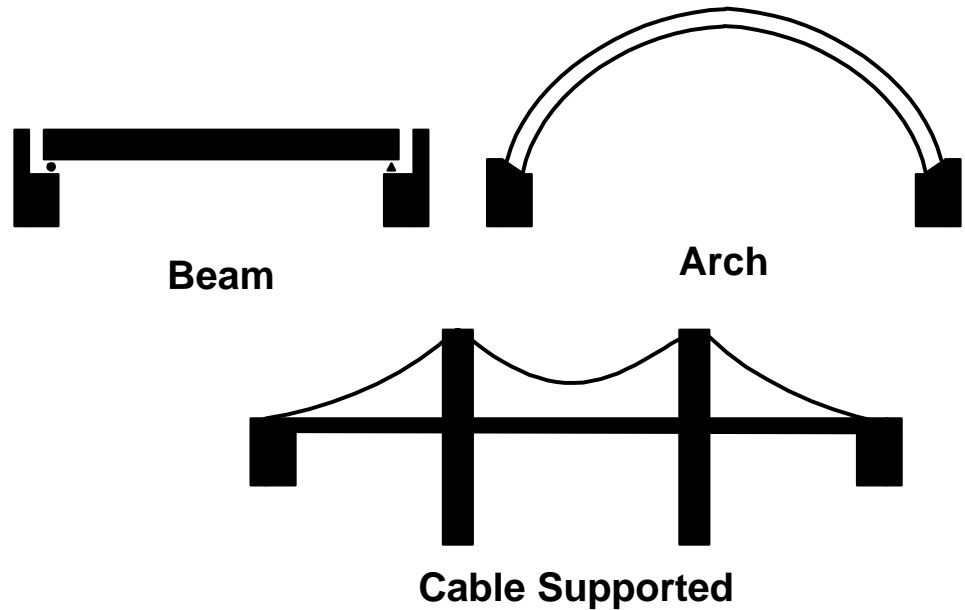

**Figure P.1.44** Three Basic Bridge Types

#### **Beam Bridges**

In the case of beam bridges, loads from the superstructure are transmitted vertically to the substructure. Examples of beam bridges include:

- Slabs (concrete) (see Figure P.1.45)
- Beams (timber, concrete, or steel) (see Figures P.1.46, P.1.50, P.1.51)
- Girders (concrete or steel) (see Figures P.1.47, P.1.48, P.1.49, P.1.52)
- Trusses (timber or steel) (see Figures P.1.53 and P.1.54)



**Figure P.1.45** Slab Bridge



**Figure P.1.46** Timber Beam Bridge



**Figure P.1.47** Prestressed Concrete Multi-Girder Bridge



**Figure P.1.48** Girder Floorbeam Stringer Bridge



**Figure P.1.49** Curved Girder Bridge





**Figure P.1.50** Tee Beam Bridge



**Figure P.1.51** Adjacent Box Beam Bridge





**Figure P.1.52** Steel Box Girder Bridge



**Figure P.1.53** Deck Truss Bridge



**Figure P.1.54** Through Truss Bridge

### **Arch Bridges**

In the case of arch bridges, the loads from the superstructure are transmitted diagonally to the substructure. True arches are in pure compression. Arch bridges can be constructed from timber, concrete, or steel (see Figures P.1.55 and P.1.56).



**Figure P.1.55** Concrete Deck Arch Bridge





**Figure P.1.56** Through Arch Bridge

### **Cable-Supported Bridges**

In the case of cable-supported bridges, the superstructure loads are resisted by cables which act in tension. The cable forces are then resisted by the substructure anchorages and towers. Cable-supported bridges can be either suspension or cable-stayed (see Figures P.1.57 and P.1.58). Refer to Topic 12.1 for a more detailed explanation on cable-supported bridges.



**Figure P.1.57** Steel Suspension Bridge



**Figure P.1.58** Cable-stayed Bridge

### **Movable Bridge**

Movable bridges are constructed across designated "Navigable Waters of the United States," in accordance with "Permit Drawings" approved by the U.S. Coast Guard. The purpose of a movable bridge is to provide the appropriate channel width and underclearance for passing water vessels when fully opened. Refer to Topic 12.2 for a more detailed explanation on movable bridges.

Movable bridges can be classified into three general groups:

- Bascule (see Figure P.1.59)
- Swing (see Figure P.1.60)
- Lift (see Figure P.1.61)





**Figure P.1.59** Bascule Bridge



**Figure P.1.60** Swing Bridge



**Figure P.1.61** Lift Bridge

### Floating Bridges

Although uncommon, some states have bridges that are not supported by a substructure. Instead, they are supported by water. The elevation of the bridge will change as the water level fluctuates.



**Figure P.1.62** Floating Bridge

### Culverts

A culvert is primarily a hydraulic structure, and its main purpose is to transport water flow efficiently.



Culverts are often viewed as small bridges, being constructed entirely below and independent of the roadway surface. However, culverts do not have a deck, superstructure, or substructure (see Figure P.1.63). Refer to Topics P.3, 12.3 and 12.4 for a more detailed explanation on culverts.



**Figure P.1.63** Culvert

## **P.1.8**

### **Bearings**

#### **Definition**

A bridge bearing is a superstructure element which provides an interface between the superstructure and the substructure.

#### **Primary Function**

There are three primary functions of a bridge bearing:

- Transmit all loads from the superstructure to the substructure
- Permit longitudinal movement of the superstructure due to thermal expansion and contraction
- Allow rotation caused by dead and live load deflection

Bearings that do not allow for translation or movement of the superstructure are referred to as fixed bearings. Bearings that allow for the displacement of the structure are known as expansion bearings. Both fixed and expansion bearings permit rotation.

#### **Basic Elements**

A bridge bearing can be broken down into four basic elements (see Figure P.1.64):

- Sole plate
- Masonry plate

- Bearing or bearing surfaces
- Anchorage

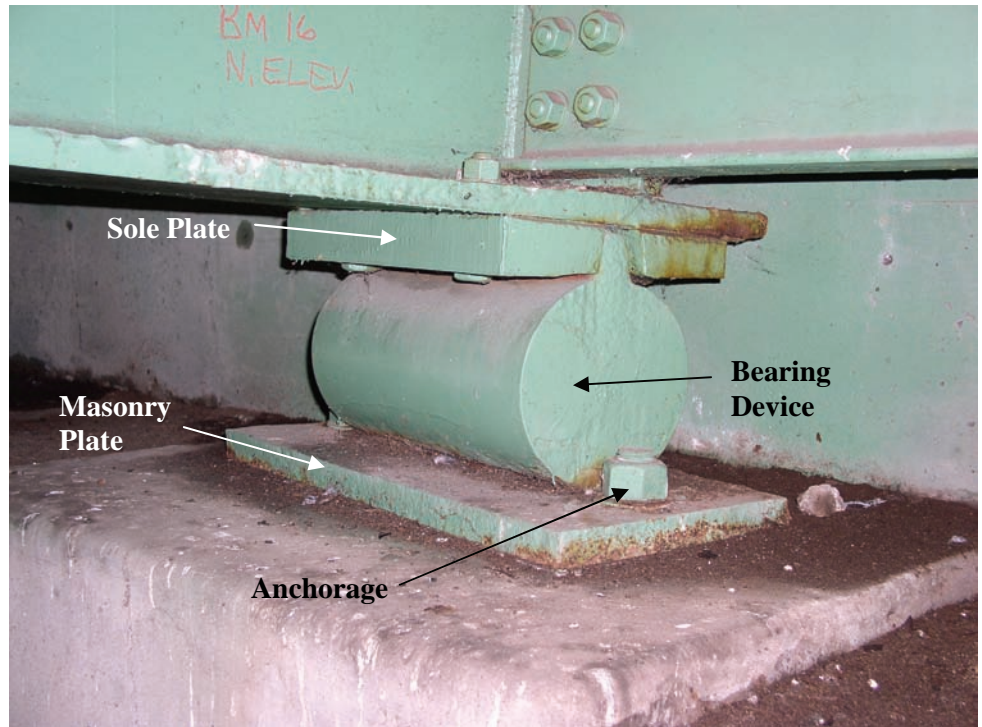

**Figure P.1.64** Typical Bearing Showing Four Basic Elements

### Bearing Types

Various bearing types have evolved out of the need to accommodate superstructure movement and rotation:

- Sliding plate bearings
- Roller bearings
- Rocker bearings
- Pin and link bearings
- Elastomeric bearings
- Pot bearings
- Restraining bearings
- Isolation bearings

Refer to Topic 9.1 for a more detailed explanation on bridge bearings.

### **P.1.9**

#### **Substructure**

The substructure is the component of a bridge which includes all the elements which support the superstructure.

#### **Substructure Purposes**

The purpose of the substructure is to transfer the loads from the superstructure to the foundation soil or rock. Typically the substructure includes all elements below the bearings. The loads are then distributed to the earth through the footing.



**Substructure Function**

Substructure units function as both axially-loaded and bending members. These units resist both vertical and horizontal loads applied from the superstructure and roadway embankment. Substructures are divided into two basic categories:

- Abutments
- Piers and bents

Abutments provide support for the ends of the superstructure and retain the roadway approach embankment (see Figure P.1.65). Piers and bents provide support for the superstructure at intermediate points along the bridge spans with a minimum obstruction to the flow of traffic or water (see Figure P.1.66).



**Figure P.1.65** Concrete Abutment

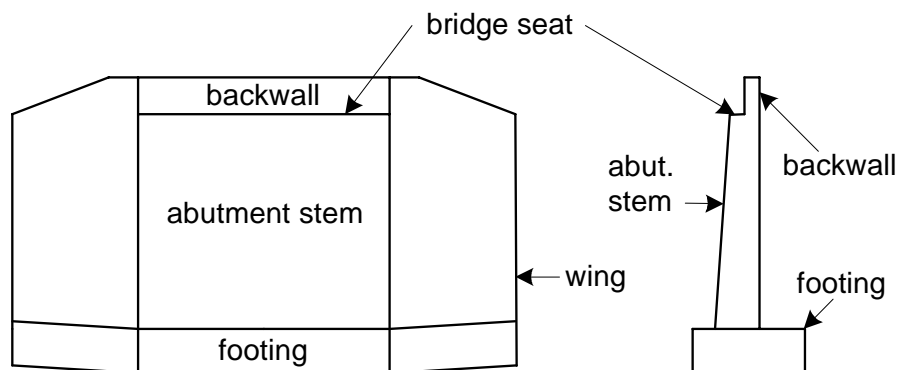

**Figure P.1.66** Concrete Pier

### Abutments

Basic types of abutments include:

- Cantilever or full height abutment - extends from the grade line of the roadway or waterway below, to that of the road overhead (see Figure P.1.67).
- Stub, semi-stub, or shelf abutment - located within the topmost portion of the end of an embankment or slope. In the case of a stub, less of the abutment stem is visible than in the case of the full height abutment. Most new construction uses this type of abutment. These abutments may be required to be supported on deep foundations (see Figure P.1.68).
- Spill-through or open abutment - consists of columns and has no solid wall, but rather is open to the embankment material. The approach embankment material is usually rock (see Figure P.1.69).



**Figure P.1.67** Cantilever Abutment (or Full Height Abutment)

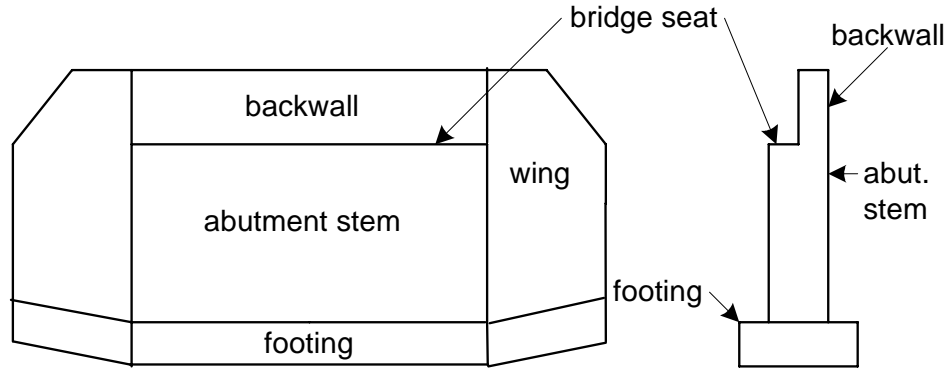

**Figure P.1.68** Stub Abutment

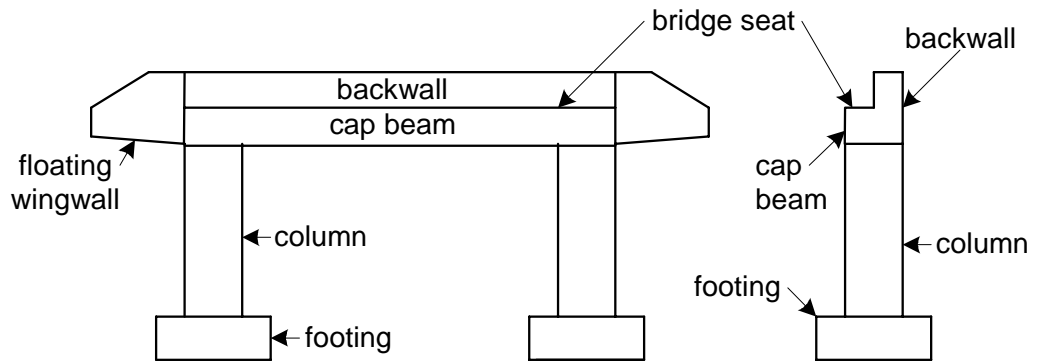

**Figure P.1.69** Open Abutment

Refer to Topic 10.1 for a more detailed explanation on bridge abutments.

### Piers and Bents

A pier has only one footing at each substructure unit (the footing may serve as a pile cap). A bent has several footings or no footing, as is the case with a pile bent. Refer to Topic 10.2 for a more detailed explanation on bridge piers and bents.

There are four basic types of piers:

- Solid shaft pier (see Figures P.1.70 and P.1.71)
- Column pier (see Figure P.1.72)
- Column pier with web wall (see Figure P.1.73)
- Cantilever or hammerhead pier (see Figure P.1.74)



**Figure P.1.70** Solid Shaft Pier



**Figure P.1.71** Solid Shaft Pier





**Figure P.1.72** Column Pier



**Figure P.1.73** Column Pier with Web Wall



**Figure P.1.74** Cantilever or Hammerhead Pier

There are two basic types of bents:

- Column bent (see Figure P.1.75)
- Pile bent (see Figure P.1.76)

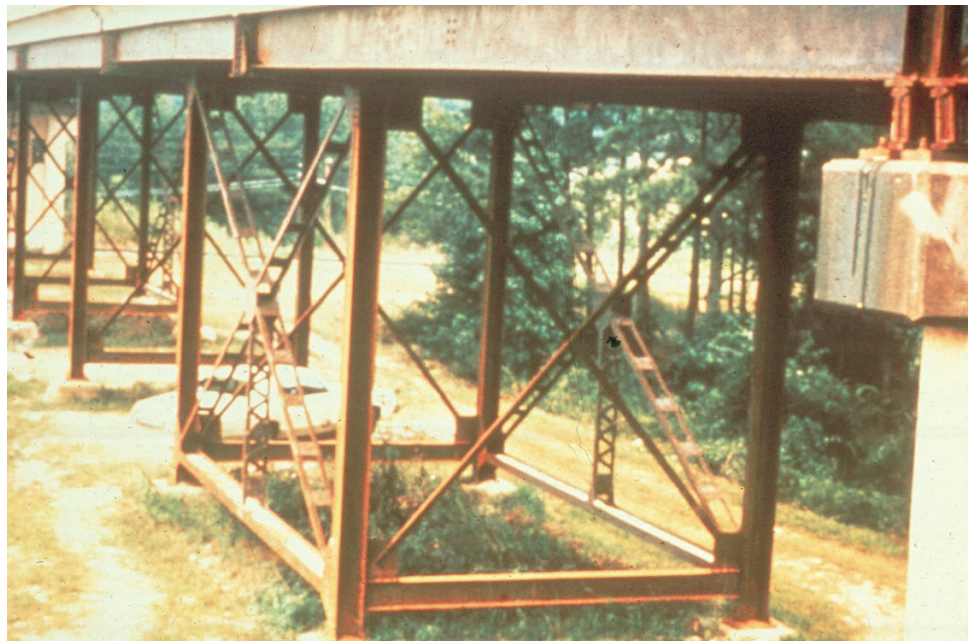

**Figure P.1.75** Column Bent





**Figure P.1.76** Pile Bent