

---

# An Introduction to Static Electricity and Lightning Protection Systems

Course No: E02-018

Credit: 2 PDH

---

J. Paul Guyer, P.E., R.A., Fellow ASCE, Fellow AEI

---



Continuing Education and Development, Inc.  
22 Stonewall Court  
Woodcliff Lake, NJ 07677

P: (877) 322-5800  
[info@cedengineering.com](mailto:info@cedengineering.com)

---

# An Introduction to Static Electricity and Lightning Protection Systems



J. Paul Guyer, P.E., R.A.  
Editor

Paul Guyer is a registered civil engineer, mechanical engineer, fire protection engineer and architect with 35 years of experience designing buildings and related infrastructure. For an additional 9 years he was a principal staff advisor to the California Legislature on capital outlay and infrastructure issues. He is a graduate of Stanford University and has held numerous national, state and local offices with the American Society of Civil Engineers, Architectural Engineering Institute and National Society of Professional Engineers. He is a Fellow of ASCE and AEI.

## **CONTENTS**

- 1. INTRODUCTION**
- 2. STATIC ELECTRICITY PROTECTION**
- 3. LIGHTNING PROTECTION SYSTEMS**

*(This publication is adapted from the Unified Facilities Criteria of the United States government which are in the public domain, have been authorized for unlimited distribution, and are not copyrighted.)*

## 1. INTRODUCTION

**1.1 PURPOSE.** This publication provides technical guidance and design requirements for static electricity and lightning protection systems as well as related grounding systems for facilities and other structures. The information provided here must be utilized by electrical engineers in the development of the plans, specifications and calculations, and must serve as the minimum electrical design requirements. Project conditions may dictate the need for a design that exceeds these minimum requirements.

**1.2 KEY CODES AND STANDARDS.** Comply with the following codes and standards:

- IEEE 142, *IEEE Recommended Practice for Grounding of Industrial and Commercial Power Systems.*
- NFPA 70, *National Electrical Code.*
- NFPA 70B, *Recommended Practice for Electrical Equipment Maintenance.*
- NFPA 77, *Recommended Practice on Static Electricity.*
- NFPA 780, *Standard for the Installation of Lightning Protection Systems.*
- UL 96, *Lightning Protection Components.*
- UL 467, *Grounding and Bonding Equipment.*

## **2. STATIC ELECTRICITY PROTECTION**

**2.1 STATIC GROUNDING AND BONDING REQUIREMENTS.** Identify hazardous classified locations in accordance with NFPA 70. Provide grounding and bonding for these areas in accordance with NFPA 77 to support the intended operations. Include a listing of hazardous materials, containers, and operating units in the design, and indicate fixed operating equipment locations on the drawings. Identify portable and movable equipment requiring static electricity grounding, distinctively by location and with type of grounding method each location requires.

**2.1.1 BONDING AND GROUNDING CONDUCTORS.** Bonding and grounding conductors must be large enough to withstand mechanical damage and must not be smaller than 6 AWG copper. For added flexibility, use braided cable or flexible bonding strap for static grounds on portable or movable equipment. Install at least two separate braided cables or flexible bonding straps on portable or movable equipment such as doors, hinged shelves, or tables. Conductors are typically uninsulated. Apply bonding for other facilities in accordance with NFPA 70 and NFPA 780. Before securing any bond, ensure electrical continuity by removing any paint, oil, dirt, or rust on contact surfaces. Bonds shall have a resistance reading of one ohm or less.

**2.1.2 CONNECTIONS.** Do not connect static grounds above grade to:

- Electrical equipment grounding systems
- Telecommunications system grounds
- Gas, steam, oil, hydraulic, hot water or air lines
- Sprinkler systems
- Any component of the lightning protection system (LPS)

These systems shall be interconnected below grade. Connection above grade to a down conductor of the LPS is authorized if the down conductor is within the bonding distance calculated in NFPA 780. As an exception to performing the calculations required by NFPA 780, the 6 foot (1.83 m) bonding requirement allowed by UL 96A can be used. The

preferred method for reducing the potential for sideflash is to increase the separation distance, so that a bond is not required. The minimum size of the bonding conductor is 6 AWG copper.

Bond other interior grounding system conductors separately to static electricity bonding jumpers or other bonded metals, and connect at or below finished grade to an appropriate grounding electrode or grounding system. Steel framing members of the building and metal siding that are electrically bonded together and not used for lightning protection may be used as part of the grounding conductor system, but no penetrations into exterior steel siding or other exterior finish are allowed above ground level, whether sealed or not.

**2.1.3 STATIC BUS BARS.** A static bus typically consists of 2 inch x ¼ inch (51 mm x 6 mm) copper bars installed on the interior wall of the facility, as shown in Figure 2.1. Static bus bars shall be used only for static grounding. Bus bars, especially those used in the telecommunications industry, come with insulators. Static bus bars shall be isolated from other grounding subsystems as much as possible and must be isolated when used for ordnance grounding and from lightning protection down conductors including steel columns used as the down conductor. The grounding system for the static bus bars is typically connected to the building grounding system below grade at a ground ring or ground rod.

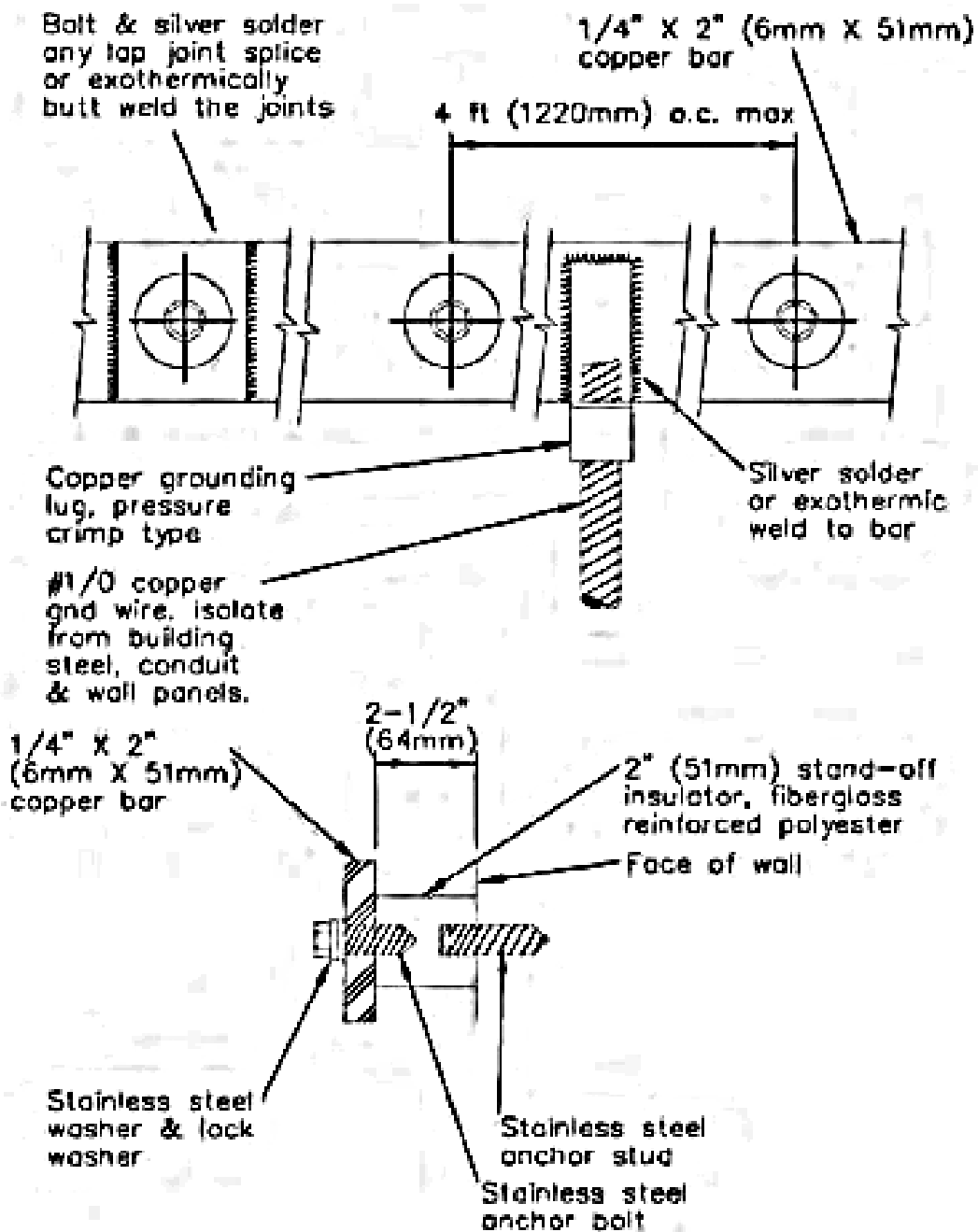

Figure 2.1  
Static Bus Bar

**2.1.4 RESISTANCE TO GROUND.** Current caused by static electricity is typically on the order of milliamperes. A resistance to ground of 10,000 ohms is more than adequate to bleed off normal static charges. All grounds used for static protection in DOD facilities, including those for aircraft and fuel tanks, must have a maximum resistance of 10,000 ohms. Any danger of electrical shock hazard caused by the 10,000 ohm value can be eliminated by proper bonding to other grounding media.

**2.1.5 GROUND GRAB BARS.** Ground grab bars may be installed immediately outside entrance doors to operating buildings, rooms or structures where special hazards exist. A ground grab bar consists of a length of non-corroding conductive pipe or bar which is connected to the earth electrode system (EES).

## **2.2 GENERAL APPLICATIONS.**

**2.2.1 CONDITIONS.** This publication does not identify all applications where static electricity protection should be provided. The electrical designer must analyze suspected potential static electricity charges and address the conductive paths that could reasonably exist between them, particularly in the following conditions:

- Hazardous area classifications and locations as listed in the NFPA 70. The electrical design must incorporate the requirements of the using service relative to hazardous materials, equipment, and containers to enable the construction contractor to proceed with a full understanding of static electricity protection requirements.
- Locations containing hazardous materials that will be handled or stored.
- Movable and portable equipment having static electricity generating capabilities potentially dangerous to personnel.



- Locations containing explosives or related type materials need to comply with applicable requirements for such facilities; refer to the paragraph titled “Key Codes and Standards”.

**2.2.2 APPLICATIONS.** Comply with NFPA 77, including the following types of applications:

- Spray painting operations; also apply NFPA 33
- Conductive flooring
- Conductive conveyor belts and V-belts.
- Humidification. If humidification is used to control static electricity discharges, daily checks are required to ensure humidity levels are maintained within specified levels.

Static electricity protection for other facilities shall satisfy the requirements within this publication. Protection for other facilities shall be assessed on a project-by-project basis only. Where criteria of other agencies conflict with criteria contained in this publication, the more stringent criteria apply. Ionization techniques are covered in NFPA 77. Ionization techniques are not to be used in hazardous areas. Radioactive ionization sources are not allowed.

## **2.3 SPECIFIC APPLICATIONS.**

**2.3.1 PETROLEUM OIL LUBRICANTS (POL) FACILITIES.** This paragraph pertains to static electricity protection for pumping, distribution, fueling and defueling storage and miscellaneous handling facilities. The following items shall be grounded directly to an earth electrode system (EES). Resistance to ground shall not exceed 10,000 ohms.

- Installations that use a static grounding/bonding reel shall ensure the resistance through the reel is 10 ohms or less.
- Aircraft direct fueling stations and hydrant fuel pits. Locate grounds on the aircraft side of any insulating flange used to isolate for cathodic protection systems.

**2.3.2 HOSPITALS.** Comply with NFPA 99 for static electricity protection required for hospitals.

**2.3.3 AIRCRAFT PARKING APRONS AND HANGAR FLOORS.** Do not use static grounds or grounding receptacles for aircraft lightning protection.

**2.3.3.1 AIRCRAFT PARKING APRONS.**

**2.3.3.1.1 STATIC GROUNDS.** Provide static grounds with less than 10,000 ohms on aprons; in airplane parking hydrant fueling and defueling areas; and near each hydrant pit.

- For some facilities, mooring eyes/tiedowns, are permitted to be used as static grounding points. When the dimensions of the mooring eye rebar are larger than the normal static ground clamp used for the aircraft, determine if it will utilize adapters on their clamps, or if they require a separate ground system. If a ground system is required to obtain a power ground (25 ohms), use the grounding receptacle per Figure 2.3, with a grid arrangement as described in Section 2.3.3.2. Coordinate with Owner on whether or not the receptacle cover and ball chain are required to be removed for foreign objects and debris (fod) prevention.
- For some Owners, provide static grounds in concrete as illustrated in Figure 2.2 and commonly called a Shepherd's Crook.

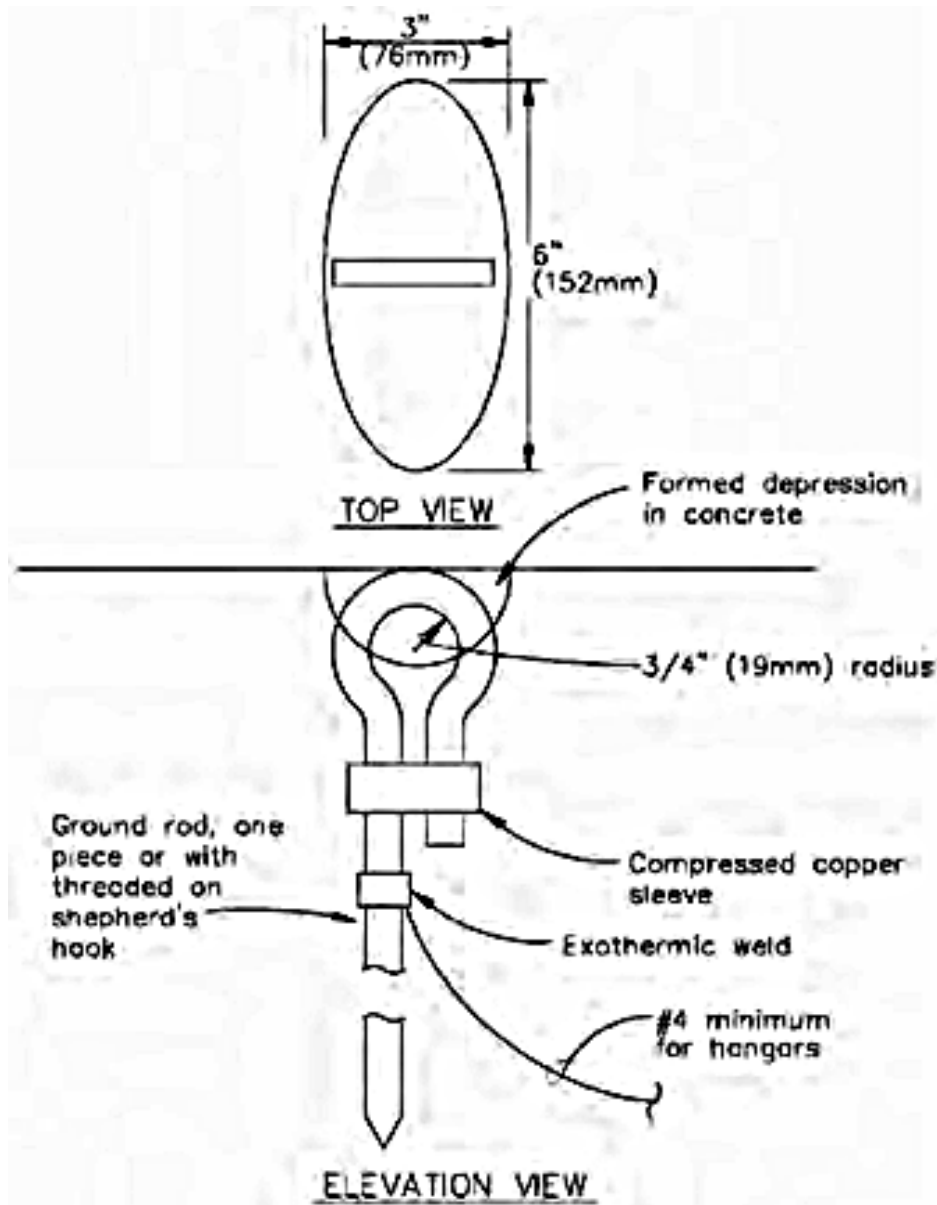

Figure 2.2  
Static Grounding Point.

**2.3.3.1.2 POWER GROUNDS.** If a power ground system with less than 25 ohms is required on an apron, use the grounding receptacle with grid per Figure 2.3.

**2.3.3.1.3 AIRCRAFT FUELING.** In addition to the criteria given herein, apply NFPA 407 when aircraft fueling is involved.

**2.3.3.2 AIRCRAFT HANGAR FLOORS.** Grounding devices installed in floors are intended to serve as aircraft static and equipment grounding. A static grounding system conforming to NFPA 77 is suitable for dissipation of any aircraft static electricity to ground. However, because NFPA 70 requires a maximum of 25 ohms resistance to ground for equipment grounding, the 25 ohm requirement governs for this dual-purpose grounding system. Interconnect floor grounding systems electrodes below concrete in a grid arrangement, and interconnect to the hangar electrical service grounding system. Use a minimum of 4 AWG bare copper for interconnections. Where hangar floors are modified, extensions to grounding receptacles shall remain load bearing to match original installation and the cover must be kept level with the finished floor. The tie-downs or grounding receptacles shall be interconnected with bare copper cable. Floor layouts for receptacles must conform to the following:

- In the absence of other guidance, hangars that will be used for a specific number and type of aircraft shall provide one grounding electrode for each aircraft space, approximately 10 ft (3 m) from the centerline of the aircraft space in the vicinity of one of the main landing gears.
- For general purpose hangars, provide electrodes for each aircraft space approximately 10 ft (3 m) from the centerline of the aircraft space, installed at 50 ft (15 m) intervals. Spacing of electrodes from wall lines or columns must not exceed 50 ft (15 m).

**2.3.3.3 GROUNDING RECEPTACLE.** Aircraft hangar floors shall use a grounding receptacle as illustrated in Figure 2.3. If a separate ground system is required for aircraft parking aprons, use the grounding receptacle with a grid as illustrated in Figure 2.3.

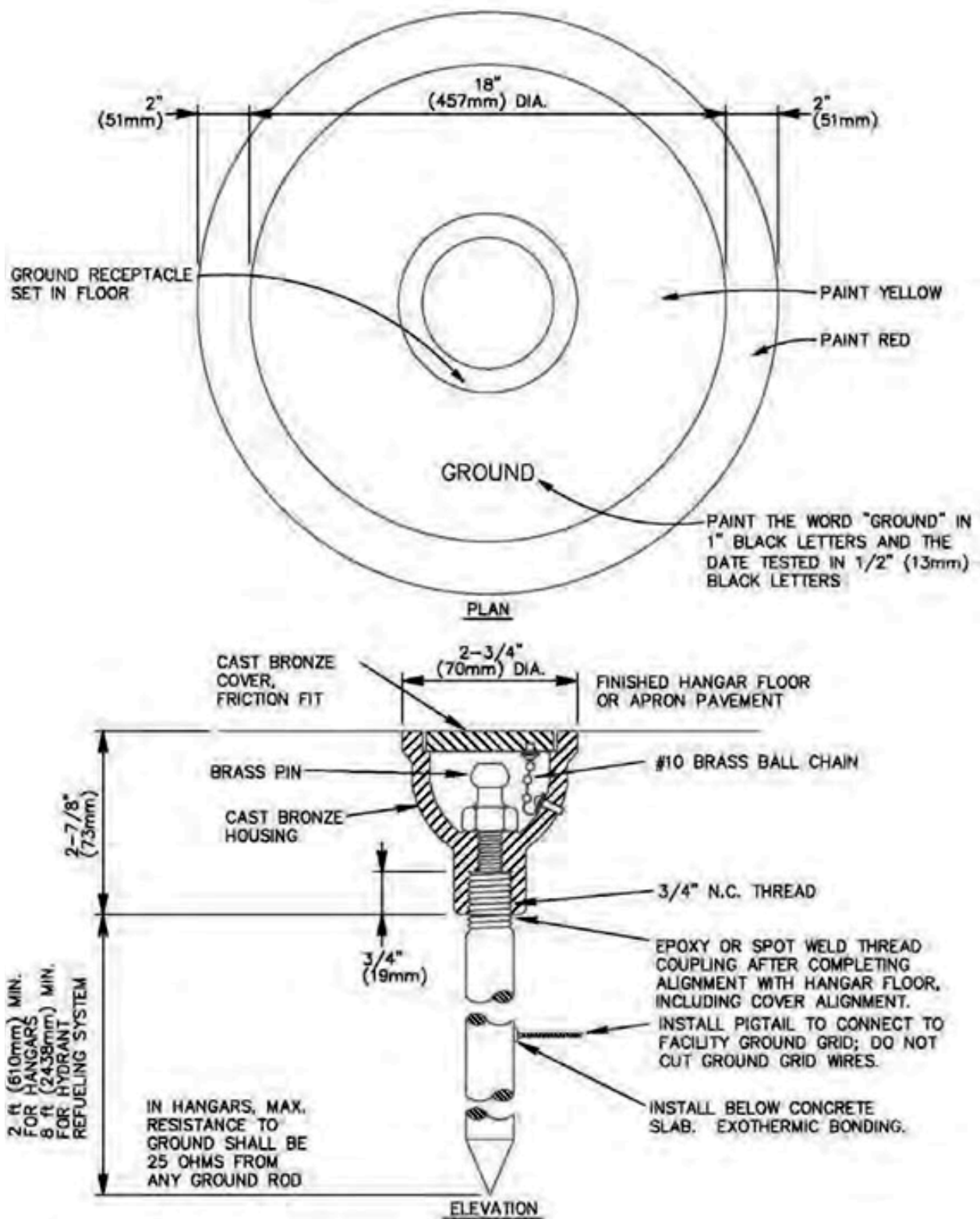

Figure 2.3 Grounding Receptacle.

*Note 1: Paint colors associated with static grounding services vary with application and service. The paint is applied directly to the hangar floor or apron pavement, and is not applied to the receptacle.*

*Note 2: When directed by the Owner, receptacle covers with a brass ball chain shown on Figure 2.3 are not required for apron pavement areas.*

*Note 3: The above criteria will be reconciled with criteria in other publications so that the required criteria is located in a single location.*

**2.3.4 AIRCRAFT SUNSHADES AND SHELTERS.** Apply NFPA 70 grounding and bonding requirements to aircraft sunshades and shelters. Obtain current guidance from each service. Validate (document in writing and date) confirmation of additional requirements or no additional requirements as of that date.

### **3. LIGHTNING PROTECTION SYSTEMS**

#### **3.1 DETERMINING THE REQUIREMENTS FOR LIGHTNING PROTECTION.**

Provide a risk assessment in accordance with NFPA 780 Annex L and document the required level of protection. Document reduced or enhanced requirements resulting from engineering decisions and good engineering practice. If lightning protection is required, provide a lightning protection system (LPS) in accordance with NFPA 780 criteria using components manufactured in accordance with UL 96. Provide a UL Lightning Protection Inspection Certificate for the facility certified to NFPA 780, unless the design and inspection are otherwise identified to comply with a different standard for a specific facility.

Evaluate planned facility modifications and additions, and determine if an LPS will be required or if an existing LPS will be affected by the modification/addition. The resulting lightning protection system for the whole facility shall be addressed in the planning and design stages. This may require some adjustment to the existing LPS. If the mission of a facility changes, determine if an LPS is required.

Note: Ensure that systems that are currently compliant with respect to lightning protection are not made noncompliant by facility modifications and additions. LPS shall be considered in the design of any project for a facility that has an LPS. This includes paint projects, roofing projects, projects requiring roof penetrations, installation of new HVAC or other metallic equipment, antenna installation, or other work. Additions and modifications to the facility envelope require re-evaluation of the LPS for the completed facility as a whole. The LPS required by the addition or modification shall not be a simple addition to the LPS. The LPS must be considered a single entity and must comply with requirements of a single LPS upon completion.

Facilities or locations which are used for the development, manufacturing, testing, handling, storage, inspection, holding or maintenance of ammunition or explosives are required to have lightning protection unless specific conditions are met. Comply with the following documents as appropriate for the service and provide a UL Lightning

Protection Inspection Certificate for the facility. This certificate shall be certified to NFPA 780, Chapter 8 and the 100 ft (30.5 m) radius rolling sphere, unless otherwise indicated by that Service; refer to the paragraph titled “Key Codes and Standards”.

**3.2 CONVENTIONAL LIGHTNING PROTECTION SYSTEMS.** Note: Nonconventional systems such as dissipation arrays and those using early streamer emission air terminals are prohibited.

**3.2.1 AIR TERMINALS.** Air terminals mounted on equipment which is exhausting hazardous vapors shall be a minimum of 60 inches (1524 mm) above the equipment to allow for the vapor to be dispersed. These air terminals require special mechanical supports per NFPA 780. Air terminals installed on “rubber” (EPDM) type roofs shall use adhesive shoes with adhesive approved by the roof manufacturer. In areas of snow and/or constant wind, ensure that a section of roofing material is first glued to the roof and then the air terminal is glued to it unless the roof manufacturer recommends another solution. This section of roofing material shall be a minimum 1 ft<sup>2</sup> (92,900 mm<sup>2</sup>).

A nonconductive pole may be used only when heights and structural strength permit and shall be provided with metal air terminals and two bare copper down conductors not less than 1/0 AWG connected to an earth electrode. The down conductors shall be placed as near as possible to 180 degrees apart and shall not be run inside the pole.

Note: The guy wire may be used as one of the down conductors, provided it is properly sized and made electrically continuous along its entire length.



**3.2.2 MASTS.** Masts of heights up to 40 ft (12.2 m) shall be of single section design. When down conductors are required because metal mast thickness is less than 3/16 inches (0.1875 inches or 4.8 mm), the down conductors shall be placed as near as possible to 180 degrees apart. All conductors and connections to the ground loop shall be run on and bonded to the outside of the mast. Wind and ice loading on the mast and on associated overhead wires shall be considered during design. Provide damping in accordance with manufacturer's recommendations. Metal mast foundation designs shall take into account wind loading and ice loading. Foundations for setting metal masts shall be in accordance with the following:

- Steel or aluminum, mounted by anchor bolts set in a concrete foundation poured in place. Follow manufacturer's recommendations for foundation design and type and for setting of anchor bolts.
- Steel, mounted by means of a stub set directly into a concrete foundation. Corrosion-resistant steel masts may be set directly into earth where soil conditions permit.

**3.2.3 JOINT DESIGN.** Slip-joint design shall meet the following requirements:

- Ensure overall structural integrity of the mast.
- Include a field assembly requirement to ensure a snug fit, so that joints of the mast will not loosen when subjected to vibration modes caused by wind or other means after erection.
- Be compatible with field erection requirements to facilitate ease of installation at the site.
- Have good metal-to-metal contact, so that electrical conductivity shall be equal to or better than the parent metal.

**3.2.4 DOWN CONDUCTORS.** Do not install down conductors inside down spouts.

**3.3 GROUNDING AND BONDING FOR LPS.** Bond equipment or subsystems into a single grounding system for the facility. Apply for general grounding system requirements. Include the following additional requirements for the LPS:

- When a ground ring is required, install the ground ring in accordance with Owner's requirements. This may require the ring to be installed at a minimum depth of 30 inches (762 mm) rather than the minimum 18-inch (457 mm) depth required by NFPA 780.
- Terminate each down conductor to a grounding electrode dedicated to the LPS. This termination can be a ground rod or can be a bond to a ground ring when a ground ring is used. If a ground ring is used, the ground ring is deemed to be associated with the LPS and thereby meets the requirements for a dedicated grounding electrode.
- In accordance with NFPA 780, facilities exceeding 75 feet (23 m) in height shall be protected with Class II materials. Use 2/0 AWG bare copper down conductors and connect to the ground ring when a ground ring is installed.
- When a facility requires an additional dedicated ground ring for a catenary lightning protection system, this ring shall be designated the primary ground ring. It shall be installed not less than 3 ft (914 mm) beyond the first (inner or secondary) ground ring and the two ground rings shall be bonded together in at least two locations.
- As an exception to performing the side flash calculations required by NFPA 780, the 6 foot (1.83 m) bonding requirement allowed by UL 96A can be used.
- Bond metal ladders to the system at both the upper and lower ends of each ladder.

**3.4 SURGE PROTECTION.** Provide appropriate class surge arresters at the distribution transformer supplying the facility. Provide surge protective devices for all systems identified in NFPA 780.

### **3.5 REQUIREMENTS FOR ORDINARY FACILITIES AND STRUCTURES.**

**3.5.1 NON-REINFORCED CONCRETE OR WOOD FRAME BUILDING.** The fastener selected shall be appropriate for the application and shall be suitable for attachment to concrete or wood. Aluminum fasteners shall not be mounted to concrete.

**3.5.2 REINFORCED CONCRETE BUILDINGS.** Do not use reinforcing steel for down conductors.

**3.5.3 STEEL FRAME BUILDING.** Down conductors may not be required when air terminals are mounted on steel which is at least 3/16 inch (4.763 mm) thick. However, use of steel framework in lieu of down conductors is permitted only if documentation is provided certifying the electrical continuity of the steel framework to less than 1 ohm when measured between the air terminal and the grounding electrode. Bolting, riveting, or welding without this certification is prohibited. Bonding across bolted or riveted construction joints may be one method used to establish or enhance electrical continuity. Install air terminals in a manner similar to Figure 3.1 when building steel is used as the down conductor.

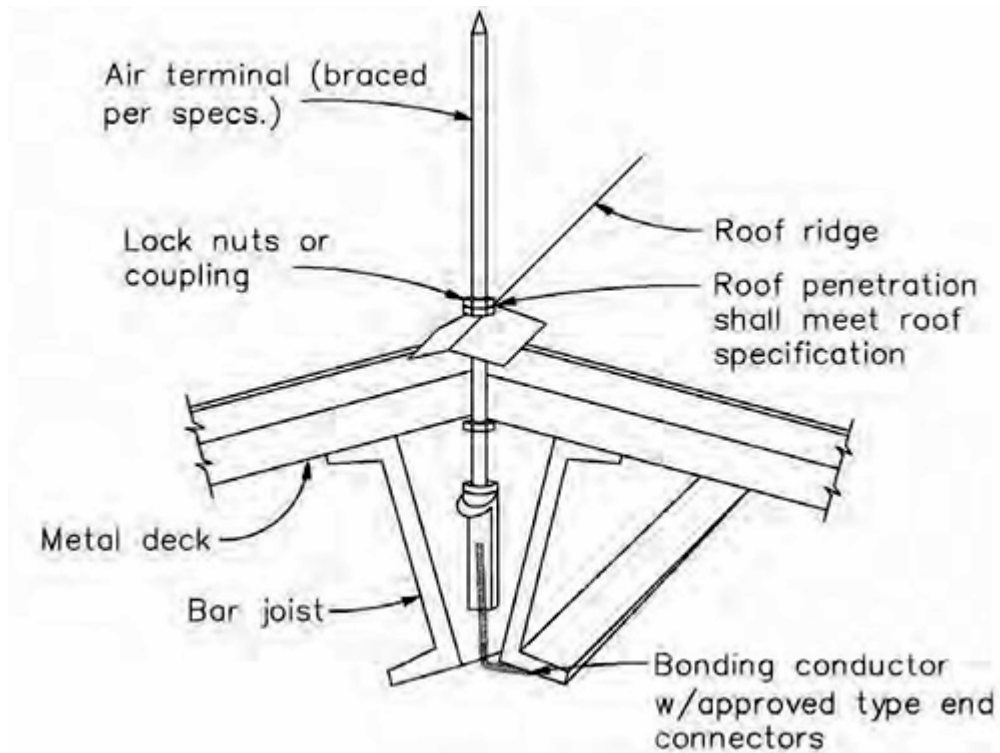

Figure 3.

Typical Air Terminal Assembly Using Steel Framing As Conductor.

**3.5.3.1 STEEL FRAMED BUILDING WITH METAL SIDING.** Bond steel columns of metal clad buildings top and bottom to metal siding.

**3.5.3.2 NONMETALLIC EXTERIOR WALLS WITH METALLIC ROOF.** When roof sections are insulated from each other, bond the metal roof sections together so that they are electrically continuous.

**3.5.4 METAL ROOF WITH METAL WALLS.** Bond metal roof and metal walls so that they are electrically continuous.

**3.5.5 RAMPS AND COVERED PASSAGEWAYS.** Verify that ramps and covered passageways do not extend beyond the zone of protection of a facility.

**3.5.6 POST TENSION SYSTEMS.** On construction utilizing post tension systems to secure precast concrete sections, the post tension rods shall not be used as a path for lightning to ground. Provide down conductors on structures using post tension systems; down conductors shall have sufficient separation from post tension rods to prevent side-flashing. Bond post tension rods to the lightning protection and grounding systems only at the base of the structure; perform this bonding according to the recommendations of the post tension rod manufacturer.

**3.5.7 BUILDINGS CONTAINING HAZARDOUS AREAS.** Bond metallic objects that are within the hazardous areas and within 10 ft (3 m) of a LPS to the nearest LPS down conductor. Bond metal frames of doors and windows within hazardous areas to the LPS. Bond doors to metal frames using flexible braid-type copper conductors. Where tested resistance is less than 1 ohm between doors and door frames, and a test plan is maintained identifying that location, a flexible braid-type copper conductor connection is not required.

**3.5.8 AIRCRAFT CONTROL NAVIGATION AIDS.** Protect one-floor frame buildings housing equipment for Instrument Landing System (ILS) and Tactical Air Navigation (TACAN) facilities and other similar type structures with no fewer than two air terminals on each facility.

**3.5.9 PETROLEUM OIL LUBRICANTS (POL) STORAGE TANKS.** Where above-ground steel storage tanks are constructed on foundations of concrete or masonry, provide grounding in accordance with the grounding schedule shown in Table 3.1, regardless of tank height. Where underground steel tanks are constructed in direct contact around the entire perimeter with not less than 18 inches (458 mm) of earth cover, grounding is not required.

Tank Circumference (Feet)	Tank Circumference (Meters)	Ground Connections Minimum Number
200 and less	61 and less	2
201 through 300	61.2 through 91.5	3
301 through 400	91.7 through 122	4
401 through 500	122.2 through 152	5
501 through 600	152.7 through 183	6
601 through 800	183.2 through 244	7
801 and more	244.2 and more	8

Table 3.1  
Fuel Storage Tank Grounding Schedule.

**3.5.10 SATELLITE DISHES.** Locate a satellite dish within the zone of protection.

## APPENDIX A

### REFERENCES

*Note: The most recent edition of referenced publications applies, unless otherwise specified.*<sup>1</sup>

IEEE (formerly Institute of Electrical and Electronics Engineers)

IEEE 142, *Recommended Practice for Grounding Industrial and Commercial Power Systems* (Green Book).

National Fire Protection Association

NFPA 33, *Standard for Spray Applications Using Flammable or Combustible Materials.*

NFPA 70, *National Electric Code.*

NFPA 70B, *Recommended Practice for Electrical Equipment Maintenance.*

NFPA 77, *Recommended Practice on Static Electricity.*

NFPA 99, *Health Care Facilities Code.*

NFPA 407, *Standard for Aircraft Fuel Servicing.*

NFPA 780, *Standard for the Installation of Lightning Protection Systems.*

Underwriter's Laboratories

UL 96, *Lightning Protection Components.*

UL 96A, *Installation Requirements for Lightning Protection Systems.* UL 467, *Grounding and Bonding Equipment.*

<sup>1</sup> Addresses for standards:

1. IEEE, 445 Hoes Lane, Piscataway, NJ 08854-4141.
2. National Fire Protection Association, One Batterymarch Park, Quincy, MA 02169-7471.
3. Underwriter's Laboratories, Inc., 333 Pfingston Road, Northbrook, IL 60062.

## APPENDIX B

### GLOSSARY

#### Acronyms and Abbreviations

AHJ	Authority Having Jurisdiction
AWG	American Wire Gauge
DOD	Department of Defense
EES	Earth Electrode System
EMI	Electromagnetic Interference
EMP	Electromagnetic Pulse
EPDM	Ethylene Propylene Diene Monomer (M-class) Rubber
ft	Feet (or Foot)
ft <sup>2</sup>	Foot Squared or Square Feet
IEEE	Formerly Institute of Electrical and Electronics Engineers
in	Inch, inches
ILS	Instrument Landing System LPS Lightning Protection System
m	Meter
m <sup>2</sup>	Meter Squared or Square Meter
mm	Millimeter
NAVFAC	Naval Facilities Engineering Command
NFPA	National Fire Protection Association
POL	Petroleum Oil Lubricants
USACE	US Army Corps of Engineers
UFC	Unified Facilities Criteria
UL	Underwriters Laboratories



## **APPENDIX B**

### **DEFINITIONS**

Activity – The end user of a facility.

Approved – Acceptable to the Authority Having Jurisdiction.

Bonding – An electrical connection between an electrically conductive object and a component of a lightning protection system that is intended to significantly reduce potential differences created by lightning currents.

Catenary System – A lightning protection system consisting of one or more overhead wires. Each overhead wire forms a catenary between masts, and serves the function of both a strike termination device and a main conductor.

Conductor, Bonding – A conductor used for equalization potential between metal bodies and the lightning protection subsystem.

Contractor – Person(s) doing actual construction portion of a project.

Copper Clad Steel – Steel with a coating of copper bonded on it.

Designer of Record – The engineer responsible for the actual preparation of the construction documents.

Down Conductor, Lightning – The conductor connecting the roof conductors or overhead ground wire to the earth ground subsystem.

Labeled – Equipment or materials to which has been attached a label, symbol, or other identifying mark of an organization that is acceptable to the authority having jurisdiction and concerned with product evaluation, that maintains periodic inspection of production

of labeled equipment or materials, and by whose labeling the manufacturer indicates compliance with appropriate standards or performance in a specified manner.

Listed – Equipment, materials, or services included in a list published by an organization that is acceptable to the authority having jurisdiction and concerned with evaluation of products or services, that maintains periodic inspection of production of listed equipment or materials or periodic evaluation of services, and whose listing states that either the equipment, material, or service meets appropriate designated standards or has been tested and found suitable for a specified purpose.