Introduction to Design of Heating and Cooling Distribution Systems

Course No: M02-021

Credit: 2 PDH

J. Paul Guyer, P.E., R.A., Fellow ASCE, Fellow AEI



Continuing Education and Development, Inc.
22 Stonewall Court
Woodcliff Lake, NJ 07677

P: (877) 322-5800
info@cedengineering.com

An Introduction to Design of Heating and Cooling Distribution Systems



Guyer Partners
44240 Clubhouse Drive
El Macero, CA 95618
(530)7758-6637
jpguyer@pacbell.net

J. Paul Guyer, P.E., R.A.

Paul Guyer is a registered civil engineer, mechanical engineer, fire protection engineer, and architect with over 35 years experience in the design of buildings and related infrastructure. For an additional 9 years he was a senior-level advisor to the California Legislature. He is a graduate of Stanford University and has held numerous national, state and local positions with the American Society of Civil Engineers and National Society of Professional Engineers.

This course is adapted from the *Unified Facilities Criteria* of the United States government, which is in the public domain, has unlimited distribution and is not copyrighted.

CONTENTS

1. INTRODUCTION
2. SYSTEM SELECTION
 - 2.1 DISTRIBUTION MEDIA SELECTION
 - 2.1.1 Connecting to an existing system
 - 2.1.2 Installation Of new system
 - 2.2 SYSTEM TYPES
 - 2.2.1 Heat Distribution Systems in Concrete Trenches
 - 2.2.2 Pre-engineered Underground Heat Distribution Systems
 - 2.2.3 Prefabricated Underground Heating/Cooling Distribution System
 - 2.2.4 Aboveground Heat Distribution System
 - 2.3 SYSTEM SELECTION
 - 2.3.1 High Temperature Water and Steam/Condensate Systems
 - 2.3.2 Low Temperature and Chilled Water Systems
3. GENERAL DISTRIBUTION SYSTEM DESIGN
 - 3.1 GENERAL
 - 3.2 SITE SOIL SURVEY
 - 3.3 UTILITY INVESTIGATION
 - 3.4 SYSTEM LAYOUT PLAN/PROFILE
 - 3.5 EXPANSION COMPENSATION
 - 3.6 VALVE MANHOLES

1. INTRODUCTION

This discussion provides criteria and guidance for the design and construction of heating and cooling distribution systems outside of buildings. The mediums used in these distribution systems include:

- High temperature hot water (HTHW) (251 deg. F to 450 deg. F)
- Low temperature hot water (LTHW) (150 deg. F to 250 deg. F)
- Low pressure steam systems (up to 15 psig)
- High pressure steam systems (over 15 psig)
- Condensate return systems (up to 200 deg. F)
- Chilled water systems.

2. SYSTEM SELECTION

When designing a heating or cooling distribution system, the designer must first select two critical items: media type and system type.

2.1 DISTRIBUTION MEDIA SELECTION.

2.1.1 Connecting to an existing system. Almost all heating and cooling distribution systems will be connected to an existing central distribution system. In this case, the designer most often designs for the media to which it is being connected-HTHW, LTHW, steam/condensate, or chilled water.

2.1.2 Installation of new system. When no existing system is present, the designer must select the system that is most appropriate for the end user. High temperature hot water and steam/condensate systems are the most common types of distribution systems currently used on military installations. However, a new system should only use the temperatures and pressures necessary to meet the requirements of the installation. For example, the use of high pressure steam sterilizers or steam kettles at several facilities may require the use of a high pressure steam or HTHW system. However, it is usually much more cost effective (on a first cost and life cycle cost basis) to use a low or medium temperature hot water distribution systems whenever possible and to incorporate stand alone high pressure/temperature systems where required. The lower maintenance costs, safer operation, longer life of systems, and simpler system controls for hot water systems often offset the costs of larger piping required. For further assistance for selecting the system type, refer to ASHRAE Handbook, "HVAC Systems and Equipment."

2.2 SYSTEM TYPES. When selecting a distribution system, the designer must determine which system types apply to a particular medium. The designer must also exclude systems which are not appropriate for a particular site or for which the customer has no interest. Examples of this are locating aboveground systems in non-industrial

areas where the installation is sensitive to the aesthetic appearance of the area or routing concrete shallow trench systems through drainage swales or flood plains.

2.2.1 Heat Distribution Systems in Concrete Trenches. This system is a buried system with its removable concrete cover installed at grade and will typically be used for HTHW and steam/condensate systems. In rare instances, it may also be used for chilled water and LTHW in the event no plastic piping is installed in the same trench as high temperature (greater than 250 degrees F) piping systems. Experience has shown that if insulation of a high temperature system is compromised, temperatures can increase to such a level and cause damage to the plastic piping.

2.2.2 Pre-engineered Underground Heat Distribution Systems. This system is designed for higher pressure and temperature applications. The two types of pre-engineered systems are the drainable-dryable-testable (DDT) type which is used for high pressure steam/condensate and HTHW at all sites, and high temperature hot water at any type of site, and the water spread limiting (WSL) type which is used only for steam/condensate systems in bad and moderate sites. HTHW supply and return lines may be provided in a single casing; however, steam and condensate lines must always be provided in separate casings because condensate lines typically last less than half as long as the steam line and are easier to replace when in a separate casing.

2.2.3 Prefabricated Underground Heating/Cooling Distribution System. This system is designed for lower temperature and pressure applications. It is typically used for LTHW, chilled water, or combination LTHW/chilled water systems.

2.2.4 Aboveground Heat Distribution System. This system may be used for HTHW, steam/condensate, and LTHW systems, and for chilled water systems where freezing is not a concern.

2.3 SYSTEM SELECTION.

The system type selected will be based on the type of media that is distributed.

2.3.1 High Temperature Water and Steam/condensate Systems. The order of preference for system types for high temperature and high pressure systems are:

- 1) **Aboveground Heat Distribution System.** This is the least expensive system and historically requires the lowest maintenance and operating costs. However, the safety and aesthetics of an aboveground system are not always desirable and must be accepted by the end user.
- 2) **Heat Distribution Systems in Concrete Trenches.** This is the most dependable of the buried distribution systems. The piping is totally accessible through removable concrete covers, the piping does not come in contact with the soil, and ground water is drained away from the piping system to low point drains. Except in rare instances, this is the system that should be selected if aboveground is not acceptable with the end user.
- 3) **Pre-engineered Underground Heat Distribution System.** This type of buried distribution system should be selected as the last option due to very short system lives which are typically caused by poor drainage, poor corrosion protection, and improper installation. Instances where it would be used would be when aboveground is not acceptable with the end user or when drainage swales and high ground water prevent the installation of a concrete trench system.

2.3.2 Low Temperature and Chilled Water Systems. The order of preference for system types for hot water, chilled water or combination hot/chilled water are:

- 1) **Aboveground Heat Distribution System.** This is the least expensive system and historically requires the lowest maintenance and operating costs. However, the aesthetics of an aboveground system are not always desirable and must be accepted by the end user. In addition, aboveground systems are typically not used for chilled water because of potential freezing problems in colder climates

and heat gain in warmer areas.

- 2) **Prefabricated Underground Heating/Cooling Distribution System.** This buried distribution system is relatively inexpensive and dependable. The non-metallic casing materials provide excellent protection from corrosion and the lower temperatures and pressures allow the system to operate for extended periods of time. It is an excellent application for chilled water since the system is installed underground, limiting the amount of heat gain to the system.

3. GENERAL DISTRIBUTION SYSTEM DESIGN

3.1 GENERAL. Some aspects of a heating or cooling distribution system design are similar regardless of the system type. These aspects are covered in this discussion.

3.2 SITE SOIL SURVEY. After general routing has been proposed and before specific design has begun, a detailed soil survey will be conducted for all distribution systems.

3.2.1 The survey will be made after the general layout of the system has been determined, will cover the entire length of the proposed system, and will be made by a geotechnical engineer. The geotechnical engineer will be a registered professional engineer with a minimum of three years of experience in the field of soil mechanics and foundation design. This engineer must also be familiar with the local soil conditions.

3.2.2 If at all possible, the survey should be conducted during the time of the year when the ground-water table is at its highest point; if this is not possible, water table measurements will be corrected, on the basis of professional judgment and local knowledge, to indicate conditions likely to exist at the time of year when the water table is at its highest point. It may be necessary to dig test pits at the worst locations to investigate the soil for evidence of high water table.

3.2.3 As a minimum, information on ground-water conditions, soil types, terrain, and precipitation rates and irrigation practices in the area of the system will be collected. This information will be obtained from available records at the installation. In addition, soil resistivity will be determined for the cathodic protection system design for Pre-Engineered Underground Heat Distribution Systems.

3.2.4 Information on ground-water conditions and soil types (in most cases not necessary for Prefabricated Underground Heating and Cooling Distribution Systems and Aboveground Heat Distribution Systems) will be obtained through borings, test pits, or other suitable exploratory means. Generally, a boring test pit will be made at least

every 100 feet along the line of the proposed system within areas of prior construction. In open undisturbed natural areas the spacing of borings may be increased. Each exploratory hole will extend to a level at least five feet below the anticipated elevation of the bottom of the proposed system. If a significant difference in underground conditions is found at adjacent exploratory points, additional explorations will be made between those points in order to determine more precisely where the change occurs. Upon completion of the survey, each exploration point will be classified on the basis of the criteria presented. The classification criteria are different for each system. Note that although classification is not a requirement for design of Prefabricated Underground Heating and Cooling Distribution Systems or Aboveground Heat Distribution Systems, the site survey, except for borings or test pits, must be conducted to ensure that actual site characteristics have been identified so that accurate plan and profile drawings can be generated.

3.3 UTILITY INVESTIGATION. All existing, concurrently constructed and new utilities will be identified if within 25 feet of the proposed distribution system routing. If the proposed routing crosses any utilities, burial depths will be determined. Utility locations and depths can be verified through personnel familiar with utilities, utility maps and by site visits. The designer is responsible for these site visits to verify locations of utility interferences and to coordinate all other construction items with the user. In the event utility information is not available, utility location consultants may be procured who specialize in the location, identification and depth determination of utilities. If interferences exist, details will be provided in the design to relocate utilities or modify system routing to avoid the interference.

3.4 SYSTEM LAYOUT PLAN/PROFILE. All distribution systems require a layout plan and profile be provided by the designer.

3.4.1 Layout plans will include, but not be limited to:

- system routing (including expansion loops and bends, manhole locations and

anchor locations).

- stationing numbering for the system (one dimensional coordinates from the point of origin of the distribution system).
- all utilities within 25 feet of the system.
- all roads and buildings clearly labeled.
- types of surface conditions (asphalt, concrete, seeding, gravel, etc.).
- grade contour lines (new and existing).
- all dimensions and clearances to ensure accurate routing.

3.4.2 A profile of the system will also be drawn and, as a minimum, show:

- all system stationing numbering.
- system slope drawn to scale (1-inch to 20 feet minimum for all systems) to all low points.
- new and existing grade.
- all existing or new utilities shown at their actual burial depths.

3.5. EXPANSION COMPENSATION. All expansion systems, loops, and bends, will be sized in order to prevent excessive pipe stresses (due mainly from thermal expansion) from exceeding those allowed by the Power Piping Code, ASME B31.1. Mechanical expansion joints are not recommended for absorbing system expansion. Mechanical expansion joints greatly increase the maintenance requirements of the distribution

systems. In the unlikely event that expansion joints must be used, they must be placed in an adequately sized valve manhole. The designer is responsible for expansion calculations for Heat Distribution Systems in Concrete Trenches, Prefabricated Underground Heating/Cooling Distribution Systems, and Aboveground Heat Distribution Systems. The designer is also responsible for the expansion and stress determinations in all the valve manholes, including the location of the equipment/pipe support locations. Even though the manufacturer is responsible for the expansion calculations for Pre-Engineered Underground Heat Distribution Systems, the calculations will be thoroughly reviewed by the designer at the shop drawing review. It is recommended that a three dimensional finite element computer program be used for determining system stresses. Many finite element software packages are available which operate on desktop computers. The temperature differential used in the stress analysis will be the maximum temperature of the media less the minimum temperature the system will encounter during a shutdown. All loops and bends will be sized based on zero percent cold springing. Cold springing effects lessen over time and are difficult to maintain in the event the system is ever cut, and shall therefore not be included in the analysis. However, loops may be installed with cold springing as an added conservative measure.

3.6 VALVE MANHOLES. For all distribution systems, valve manholes will be designed by the project designer. A valve manhole is required for all buried system lateral connections, all below to above ground system transitions, all drain points (low points), all below ground valving, all trap stations, high points for vents of buried systems, and to minimize depth of buried systems. Distance between valve manholes varies with different applications. However, spacing shall never exceed 500 feet with Pre-Engineered Underground Heat Distribution Systems or Prefabricated Underground Heating/Cooling Distribution Systems to minimize excavation when searching for failures and to minimize effects of a failure. To enhance maintainability, avoid valve manholes deeper than 6 feet.

3.6.1 Manhole internals. Layout of each manhole will be designed on a case by case

basis.

3.6.1.1 Equipment/valve locations. It is important to first layout, to scale, all manhole piping, insulation, valving (with stems upright 90 degrees or less from vertical), and equipment and then locate the manhole walls around these appurtenances to ensure adequate manhole size and room for maintenance personnel. One line diagrams of piping and equipment are unacceptable. See Figure 3-1 for a typical manhole plan. Note that all valve manhole layouts have certain designer requirements in common. The designer will:

- Provide main line isolation valves in valve manholes to most efficiently minimize outages to buildings served by the distribution system. When installed, main line isolation valves will be located downstream of the building's service laterals.
- Provide lateral isolation valves within the valve manholes for all laterals runs.
- Locate all carrier pipe vents and drains needed within the manhole for proper system drainage of the main and lateral lines.
- Layout all valve manhole internals (valves and valve stems, pipe w/insulation, access ladders, isolation flanges, and equipment) to scale to ensure adequate clearance has been provided for operation and maintenance within the manhole.
- Ensure no non-metallic piping is routed in the manholes (i.e., as allowed with chilled water or condensate return systems) which also serves high temperature mediums that could damage the non-metallic piping. Damage to non-metallic piping is caused when manholes flood and the hot piping boils the flood water. Boiling water can exceed the temperature allowables of many nonmetallic piping materials. Because of this, the designer must transition to steel piping at the manholes.

3.6.1.2 Clearances. Design will provide for clearance around piping and equipment in the manhole in accordance with Table 3-1.

3.6.1.3 Access Ladders. Access ladders will be required on all valve manholes greater than 3 feet in depth. Ladders will be welded steel and will consist of uprights and nonslip steps or rungs. Uprights will be not less than 16 inches apart and steps or rungs will be spaced no greater than 12 inches apart. Ladders will extend not less than 6 inches from the manhole wall and will be firmly anchored to the wall by steel inserts spaced not more than three 3 feet apart vertically. All parts of the ladders will be hot-dipped galvanized after fabrication in conformance with ASTM A 123. The top rung of the ladders shall be not more than 6 inches from the top of the manhole. A typical valve manhole access ladder detail is shown in Figure 3-2.

3.6.1.4 Insulation. Insulation for valves, fittings, field casing closures, and other piping system accessories in valve manholes will be of the same types and thicknesses as those provided in the distribution systems' guide specification. All insulation will be premolded, precut, or job fabricated to fit and will be removable and reusable. Insulation jackets will be provided for all pipe insulation in manholes and will comply with the requirements of the particular distribution system guide specification.

3.6.1.5 Isolation flanges. Isolation flanges will be provided when connecting to an existing cathodically protected heating or cooling distribution system or to prevent a new system's cathodic protection system from contacting an existing system. The isolation flanges will be installed in the valve manhole and a typical flange detail is shown in Figure 3-3.

3.6.1.6 Valve/piping supports. Piping in valve manholes often will need supports within the manhole especially when larger valves or equipment are attached to the piping. These supports will be located on the manhole plans as determined by the designer's expansion compensation calculations for each manhole valving and equipment layout. Typical valve/piping support details are shown in Figure 3-4.

3.6.2 Valve manhole construction. Valve manholes will be field constructed of

reinforced concrete conforming to the current criteria. Valve manholes will be constructed of 4,000 psi minimum compressive strength concrete. Reinforcing bars will conform to ASTM A 615, grade 60. Typical reinforcing steel details and sizing are shown in Figure 3-5 and Table 3-2 respectively. Concrete floor slabs and walls will be of sufficient weight to prevent flotation in high water table areas. Floor slabs will be sloped to the drain which will be installed in the floor slab. Concrete wall sections will be not less than 8 inches thick and must meet anticipated load and soil conditions. Side walls will be constructed in a monolithic pour. Water stops will be provided at all construction joints. Do not locate valve manholes in roads or parking areas which create an inadequate amount of manhole ventilation and poor access.

3.6.3 Valve manhole covers. The valve manhole cover types discussed here are: raised solid plate, supported cover, and concrete.

3.6.3.1 Raised solid plate covers. Raised solid plate covers are preferred for HTHW and steam/condensate systems installed in Pre-Engineered Underground Heat Distribution Systems. For shallow concrete trench systems, the raised solid plate cover's raised feature will interfere with the trench's walkway function. When the valve manhole cover must remain flush with the trench top, the supported cover is the preferred type. For the raised solid plate cover, ventilation openings are provided around the entire perimeter below the raised top. The height of the valve manhole wall above grade (6 inches, minimum) shall be sufficient to prevent surface water entry. The solid plate cover assembly is removable. The cover, constructed of aluminum, also provides sectionalized access for inspection and maintenance. The solid plate cover raised frame design and section, lifting lug, and handle details are shown in Figure 3-6 through 3-12. Figure 3-13 contains notes for raised solid plate cover figures.

3.6.3.2 Supported covers. Supported covers may be used for any distribution system covered here. For Pre-engineered Underground or Prefabricated Underground Heat Distribution Systems, design the cover to be at least 6 inches above the surrounding grade. When used for concrete shallow trench systems, the finished top will be flush with the concrete trench top. Required grates or other structural members used for supporting covers to be made of corrosion resistant material such as aluminum or

galvanized steel. Details for the supporting cover are shown in Figures 3-14 through 3-18. These details are designed for loadings up to 150 psf and must be re-evaluated for larger loadings. Other structural solutions for supporting the checkered plate are acceptable. The checkered plate cover (also referred to as diamond or embossed plate) as shown in Figure 3-18, will be installed over grating or other structural supports in most locations to minimize the influx of leaves and other debris. The checkered plate is attached to the grating and is removable.

3.6.3.3 Concrete covers. The use of concrete covers is discouraged, but, if used, they must be used with 4 x 4 ft. aluminum doors for any distribution system covered in this manual. Concrete covers should only be used if desired by the user or if specific design conditions exist, such as below to aboveground system transitions. When used for Pre-engineered Underground or Prefabricated Underground Heat Distribution Systems, design the top of the concrete cover to be a minimum of 6 inches above the surrounding grade. When used for concrete shallow trenches, design the cover to be flush with the trench top. Concrete requirements for this cover are similar to those required for valve manhole construction. Concrete cover will be provides construction details for this cover. The concrete cover detailed is designed for loadings up to 150 psf. For greater loadings, the design must be re-evaluated. A disadvantage of concrete covers is the difficulty in providing ventilation. For concrete shallow trench systems, a single 6 inch gooseneck pipe will be used, as detailed in Figure 3-21, to allow steam to exit the valve manhole if a leak or excessive heat loss is present. Note that for shallow trench systems, the gooseneck will be installed off to one side of the valve manhole concrete top to minimize pedestrian traffic interference. For Pre-engineered Underground Heat Distribution Systems, two 6 inch goosenecks will be used. One will extend below the top as detailed in Figure 3-21. The other will be similar but will extend to within 8 inches of the valve manhole floor on the opposite side of the manhole.

3.6.4 Valve manhole drainage. Drainage of water from the valve manhole is mandatory for the successful operation and longevity of buried heating or cooling distribution systems. There are three types of valve manhole drainage systems described in this manual: gravity drainage, pumped drainage from a sump basin,

and pumped drainage from the valve manhole.

3.6.4.1 Gravity drainage. The most cost effective and lowest maintenance system is gravity drainage to a storm drain when location, depth of existing storm drains, and local regulatory requirements allow this possibility. Drainage lines will be 6 inches in diameter minimum and will conform to the latest storm drain criteria and will be sloped at one percent, minimum. Valve manhole outlet will be a floor drain with backflow preventer to prevent storm water inflow from the storm drain (see Figure 3-22). Note that valve manhole drain outlets shall be covered with a "hat type" cast iron pipe screen to minimize the accumulation of trash over the drain inlet. Also, the manhole floor will be sloped toward the drain.

3.6.4.2 Pumped drainage from sump basin. For pumped drainage, a duplex submersible pump system installed in a remote sump basin may be provided as indicated in Figures 3-23 and 3-24. The sump basin will be located no more than 10 feet from the valve manhole. Drainage from the valve manhole to the sump basin will be similar to drainage to a storm drain including the valve manhole floor drain (Figure 3-22). Discharge from the pumps can be routed to a splashblock at grade or to an adjacent storm sewer. Design of the surrounding grade must ensure drainage away from the sump basin, valve manhole and concrete shallow trench (if used) when discharging to grade. A power pedestal complete with failure warning light will be provided with each basin as shown in Figure 3-25. A typical wiring diagram and sequence of operation are shown in Figure 3-26. A specification for the sump basin system can be included in the applicable manhole or heat distribution section of the contract specification. The sump basin design has proven to operate well even in the colder climates of the upper tier states in the continental United States. It is also an excellent method to retrofit existing manholes that currently do not drain properly. The remote sump basin increases the life of the systems by removing the sump pump and pump controls from the hot, humid environment of the manhole. Also, pump maintenance will be done outside of the manhole. The pumps are easily disconnected and lifted to grade. The sump pumps used in the sump basin must incorporate the design characteristics listed in Table 3-3.

3.6.4.3 Pumped drainage from valve manhole. Another means to pump water from the manhole is to locate the duplex sump pumps in the valve manhole. Typically, a 2'0" by 2'0" by 1'0" (deep) sump will be provided in a corner of the valve manhole. The duplex sump pumps will be installed to pump out of this sump. Valve manhole sump pump electrical arrangement should be installed as shown in Figure 3-27. The control panel with high level warning light will be mounted adjacent to the valve manhole at grade. This keeps the electrical panel out of the hot, humid environment of the manhole. The sequence of operation and wiring diagrams will meet the requirements of Figure 3-26. Pump discharge can be routed to a splashblock at grade (similar to the sump basin discharge piping arrangement on Figure 3-23) or to an adjacent storm drain. Electric sump pumps used in the valve manholes must incorporate the design characteristics listed in Table 3-3. Note that life of the pumps are typically shortened when installed in the hot and humid valve manhole environment.

3.6.5 General.

3.6.5.1 Valve manhole wall penetrations. A design must be provided for the distribution system wall penetrations. For a shallow trench system, the wall penetrations will typically be the same size as the inside dimension of the shallow trench connecting to the valve manhole. Structural reinforcement must be designed around this opening. Drainage from the trench will then flow into the manhole. For Pre-engineered or Prefabricated Underground Heat Distribution Systems, sleeved openings will typically be provided with an expandable seal between the casing and the pipe sleeve as indicated on Figure 3-28. Structural reinforcement must be designed to avoid contact with the pipe sleeve and water stop to prevent grounding of the system's cathodic protection.

3.6.5.2 Waterproofing. Waterproof membranes will be placed in or below the concrete bottom slab and continued up the outer sides to the top of the sidewalls in accordance with the valve manhole guide specification.

3.6.5.3 Pipe anchoring adjacent to valve manholes. Regardless of the buried distribution system, pipe anchors should be provided between 2 to 5 feet of a manhole wall to minimize movement through the manhole. For piping which passes through

valve manholes, anchoring on one side only is typically adequate. Anchoring piping on more than one side may restrict piping movement and overstress the piping in the valve manhole. Anchors will typically be provided as part of the distribution system and will not be embedded in the manhole wall. However, if the manhole is used to support an anchor, the manhole must be designed to withstand the forces exerted by the system. Expansion compensation stress calculation will always be conducted to ensure proper anchor locations throughout the distribution system. These calculations must also account for the expansion in the valve manholes.

3.6.5.4 Piping materials in valve manholes. Nonmetallic piping must not be used in the same valve manholes as piping carrying higher temperature media that could cause the temperature around the non-metallic piping to exceed the allowables and potentially cause permanent damage to the non-metallic piping. In addition, chilled water systems with PVC carrier piping must never be installed in the same valve manhole with any heating system.

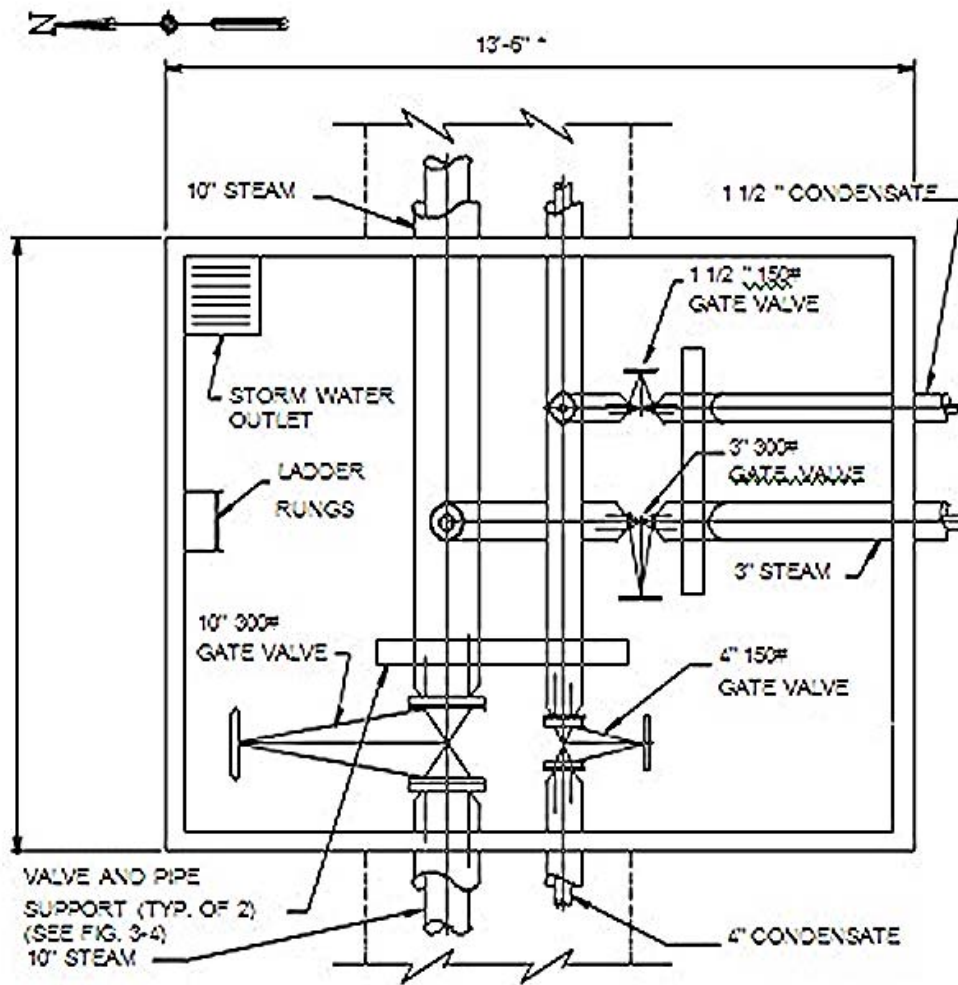
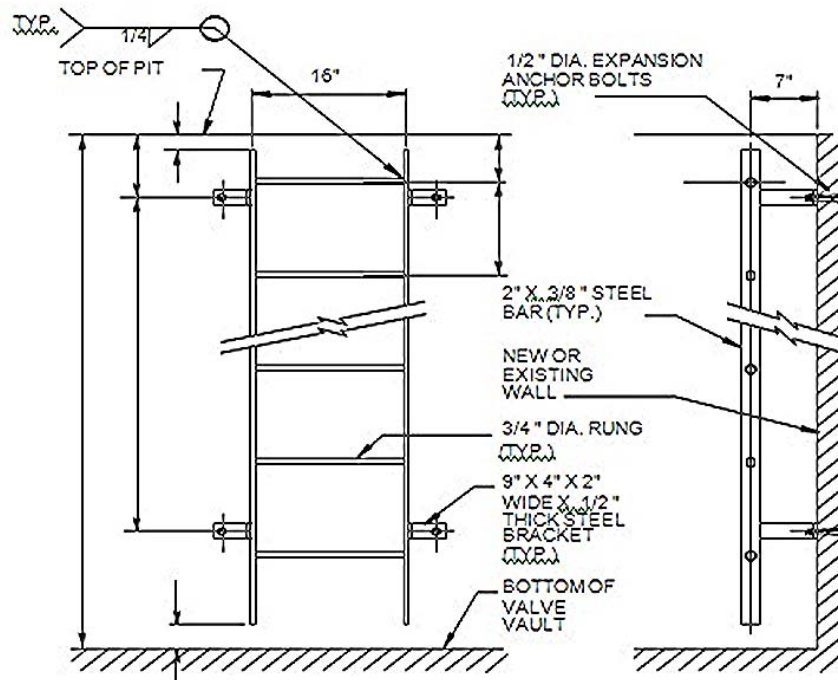
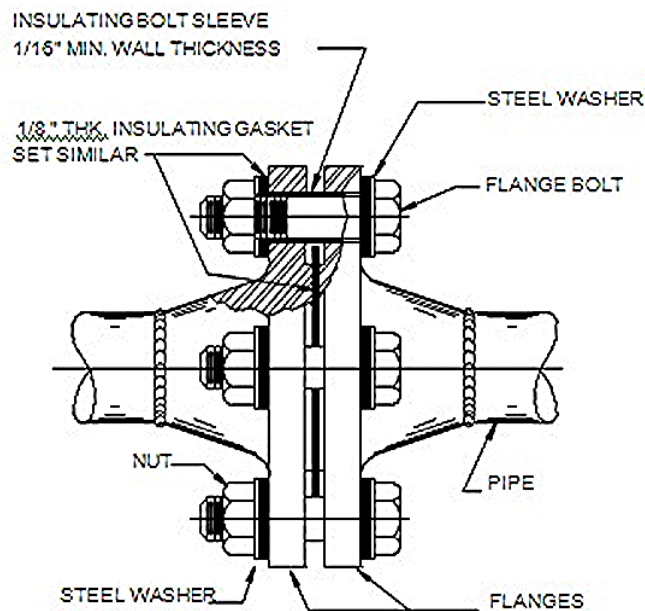

Figure 3-1



ACCESS LADDER

Figure 3-2



ISOLATION FLANGE

Figure 3-3

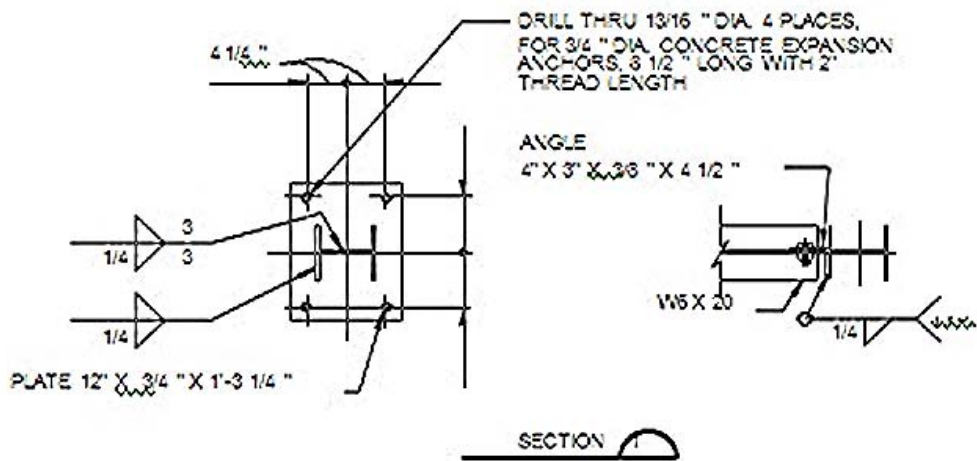

NOTES:

1. PIPING SHALL REST ON THIS PIPE SUPPORT BY MEANS OF A FREE PIPE SHOE (SUPPORT) AS DETAILED IN FIG. 4-1. PIPE SHOES SHALL BE CENTERED ON THE TOP BEAM OF THIS SUPPORT IN THE COLD CONDITION.

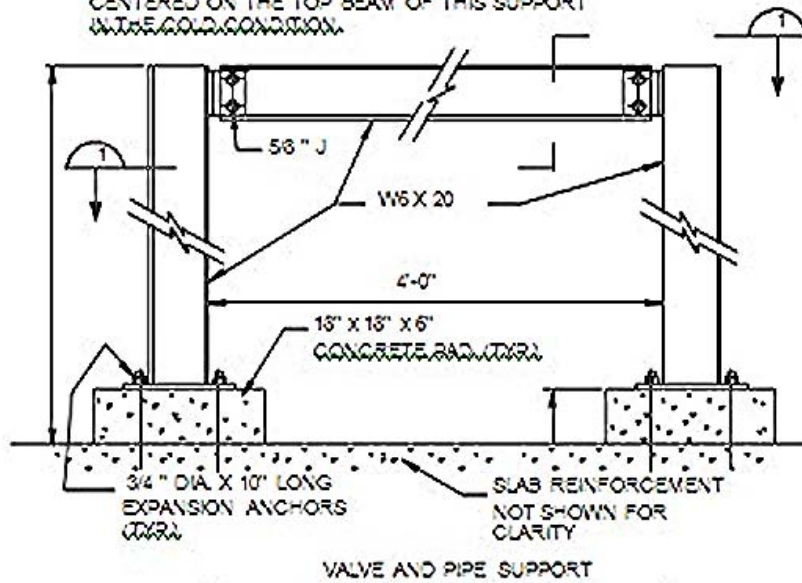
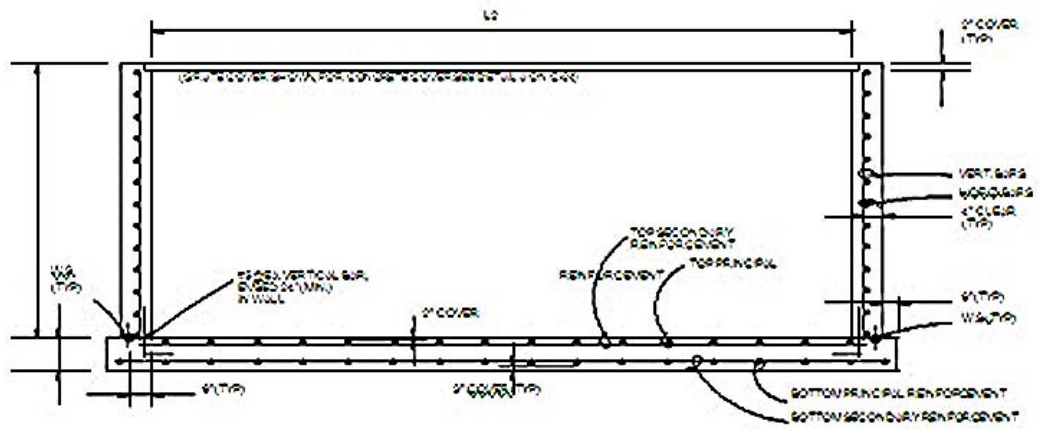
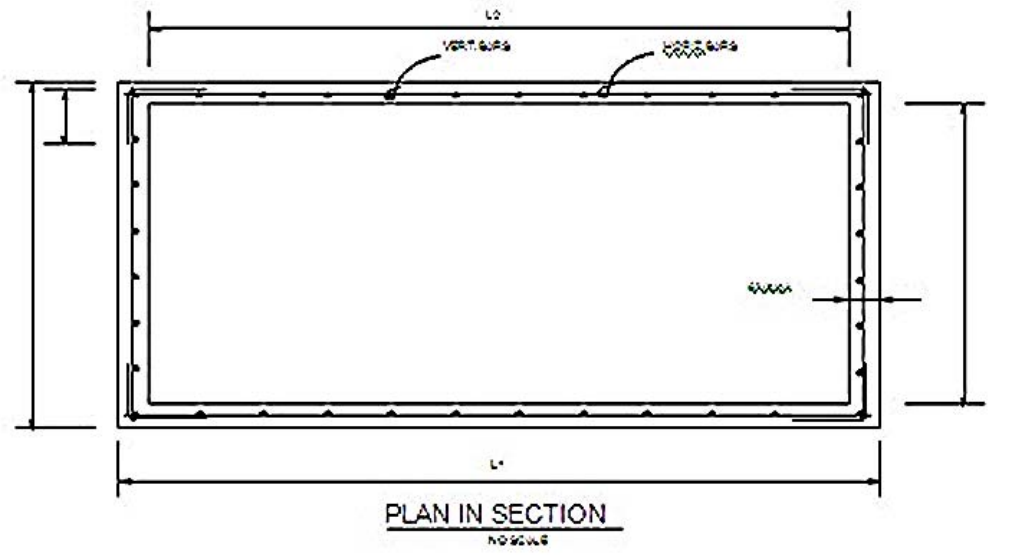

Figure 3-4



MANHOLE ELEVATION IN SECTION

Figure 3-5

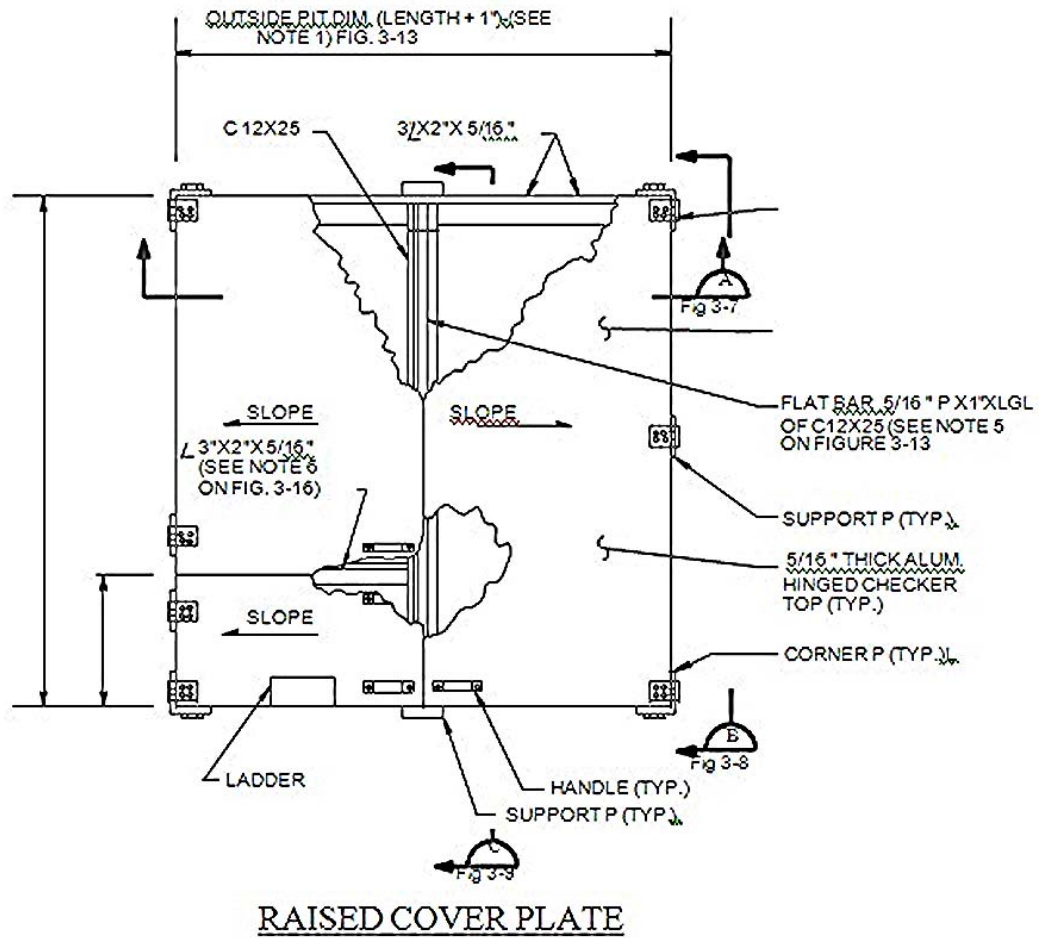
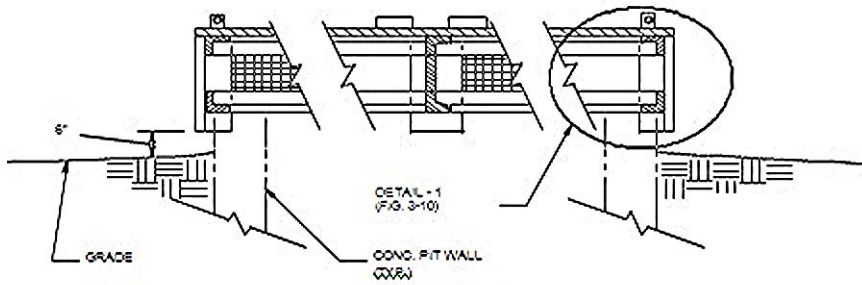
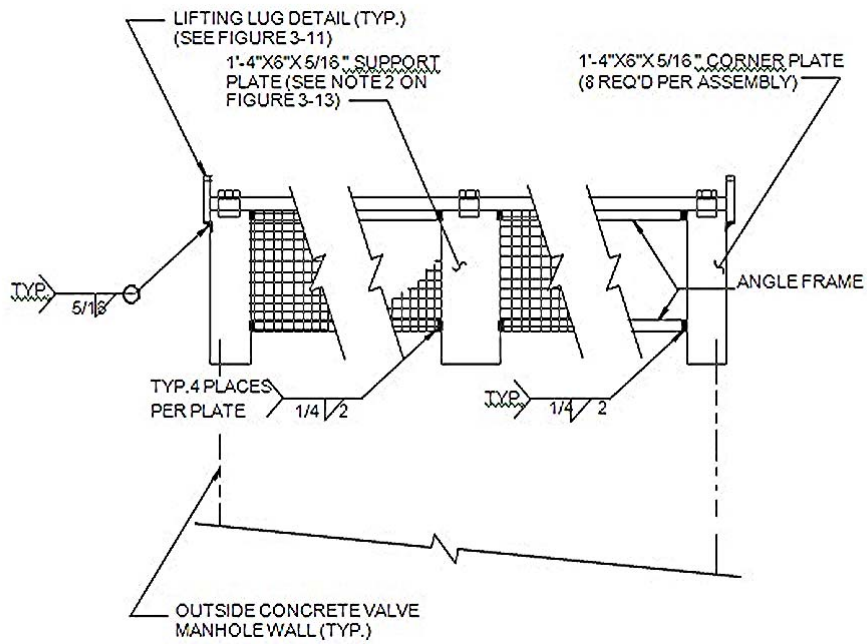

Figure 3-6



SECTION A-A OF RAISED COVER PLATE

Figure 3-7



SECTION B-B OF RAISED COVER PLATE

Figure 3-8

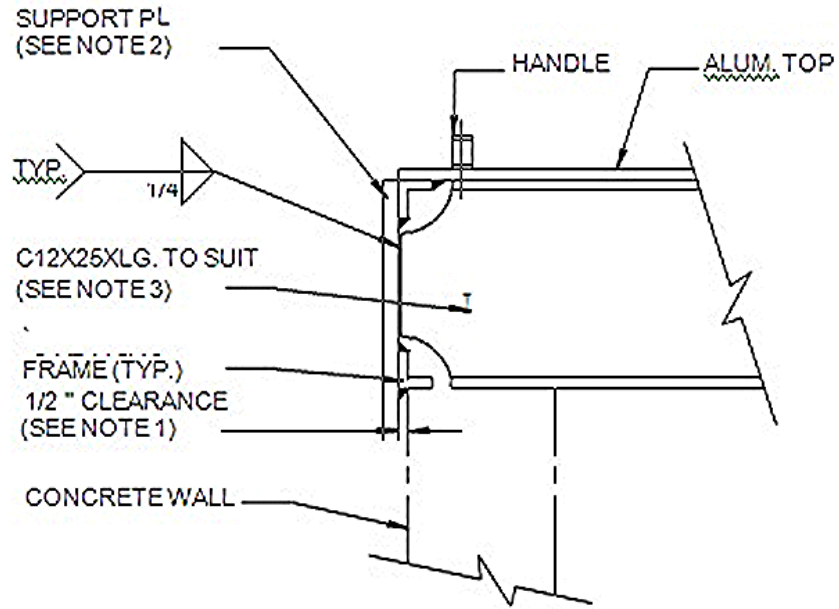

NOTE:
NOTES ARE LOCATED ON FIG. 3-13.

SECTION C-C OF RAISED COVER PLATE

Figure 3-9

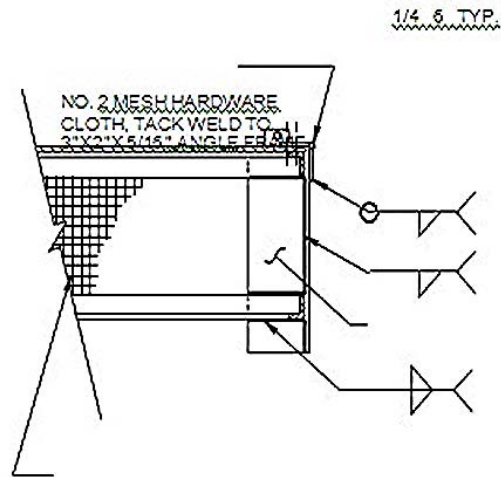
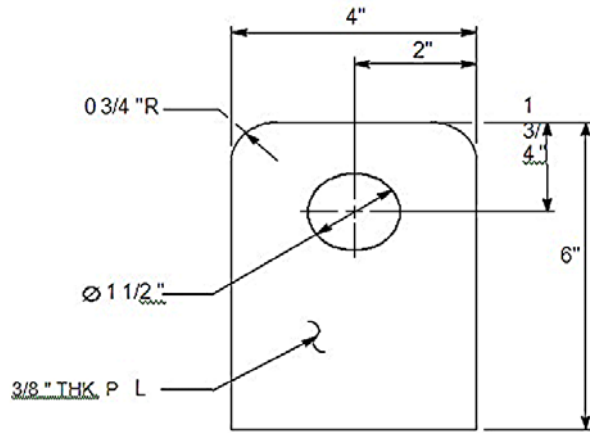

Figure 3-10



NOTE: 4 LUGS REQ'D PER ASSEMBLY

LIFTING LUG

Figure 3-11

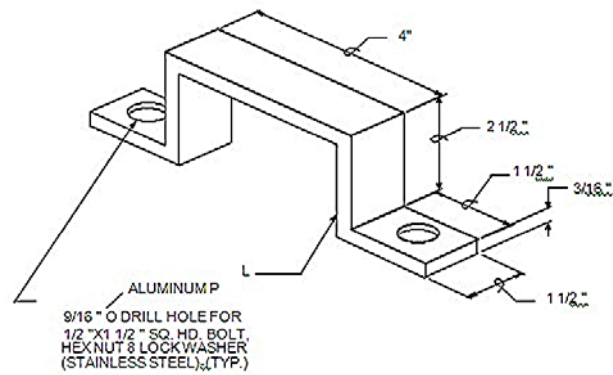

NOTE: 2 HANDLES REQ'D PER HINGED TOP,
MIN. 6 PER PIT COVER ASSEMBLY.

HANDLE

Figure 3-12

GENERAL NOTES: (FOR RAISED COVER PLATE)

1. FIELD VERIFY OUTSIDE DIMENSIONS OF NEW MANHOLE BEFORE CONSTRUCTING MANHOLE COVER ASSEMBLY. ADD 1" TO OUTSIDE MANHOLE DIMENSIONS (TO ALLOW FOR CLEARANCE) TO DETERMINE INSIDE ASSEMBLY DIMENSIONS.
2. EACH SUPPORT PLATE SHALL BE LOCATED HALFWAY BETWEEN CORNER PLATES AT 3 SIDES OF MANHOLE. 2 SUPPORT PLATES SHALL BE LOCATED BETWEEN 2 SPLIT ALUM. CHECKER TOP AT ONE SIDE OF MANHOLE.
3. SUPPORT CHANNELS SHALL BE C12X25XLG, TO EQUAL WIDTH OR LENGTH DIM. PLUS 1" TO SUIT INSIDE ASSEMBLY DIM. THE CHANNEL SHALL REST ON THE CONCRETE MANHOLE TOP AND THE ALUM. TOP SHALL REST ON THE FLAT BAR PLATE.
4. CHANNEL SUPPORT, CORNER PLATES, SUPPORT PLATES, ANGLE FRAME HARDWARE CLOTH, AND LIFTING LUGS SHALL BE HOT-DIPPED GALVANIZED BEFORE INSTALLATION ON VALVE MANHOLES.
5. FLAT BAR 5/16" THK. WELDED TO TOP OF C12X25 TO MAKE ALUM. CHECKER TOP SLIGHTLY SLOPED AS INDICATED. LOCATE FLAT BAR TO MATCH CHANNEL BEFORE WELDING.
6. ANGLE 3"X2"X 5/16" WELDED TO C12X25 8. 3"X2"X5/16" AT EACH END LENGTH SHALL EQUAL HALF OF LENGTH OR WIDTH OF VALVE MANHOLE.

Figure 3-13

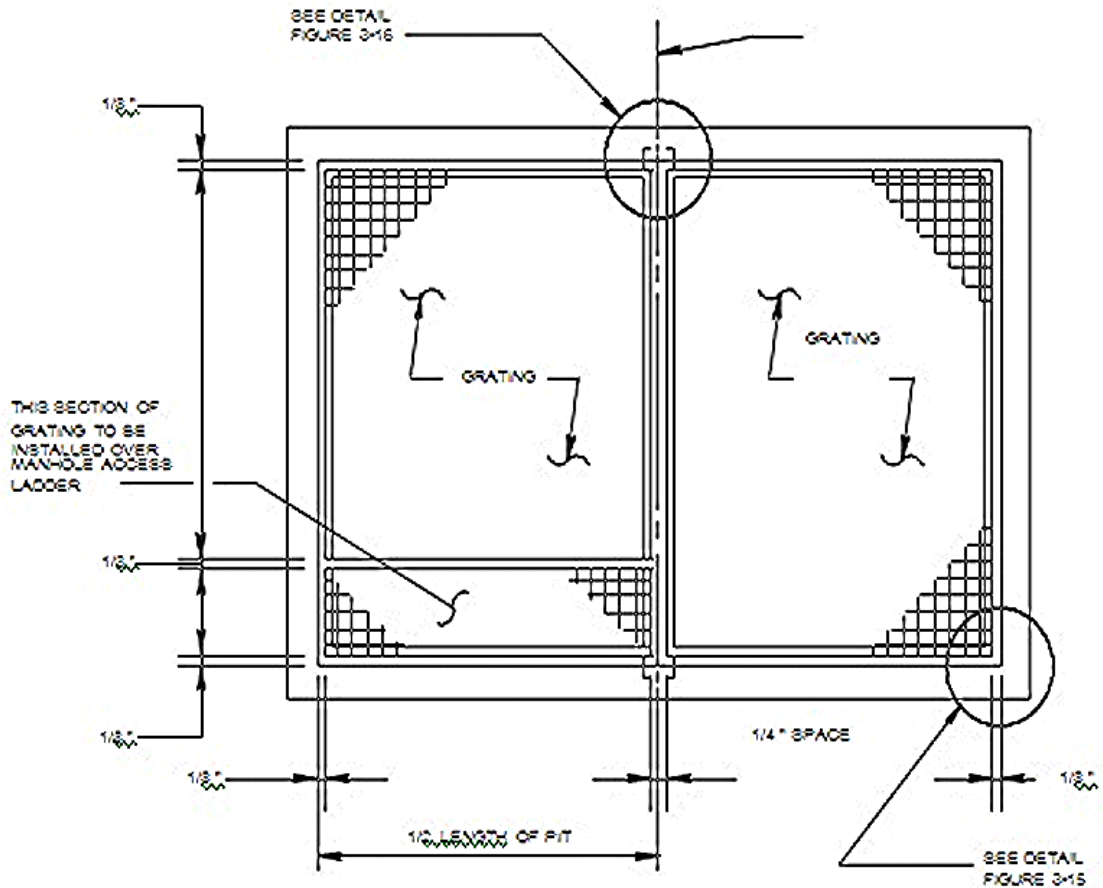

TYPICAL SUPPORTED COVER PLAN
(GRATE SUPPORT)

NO SCALE

NOTE TO DESIGNER:

GRATES IN FIGURES 3-14 THRU 3-16 ARE FOR LOADINGS UP TO 150 psf.
LOADINGS GREATER THAN THESE MUST BE DESIGNED FOR ON A CASE BY CASE BASIS.

Figure 3-14

GRATING SHALL BE GALVANIZED AND CONFORM TO
 FEDERAL
 SPECIFICATION RR-G-661, GRATING OVER MANHOLE,
 EXCEPT LADDER ACCESS PORTION, TO BE W-19-4 (1x 3/16)
 GRATING, CAPABLE OF A UNIFORM LOADING OF 145 psf.

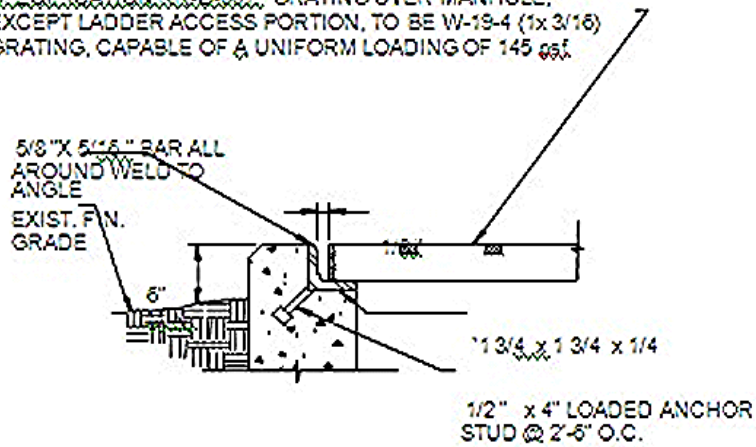

ANGLE SUPPORT FOR GRATING

Figure 3-15

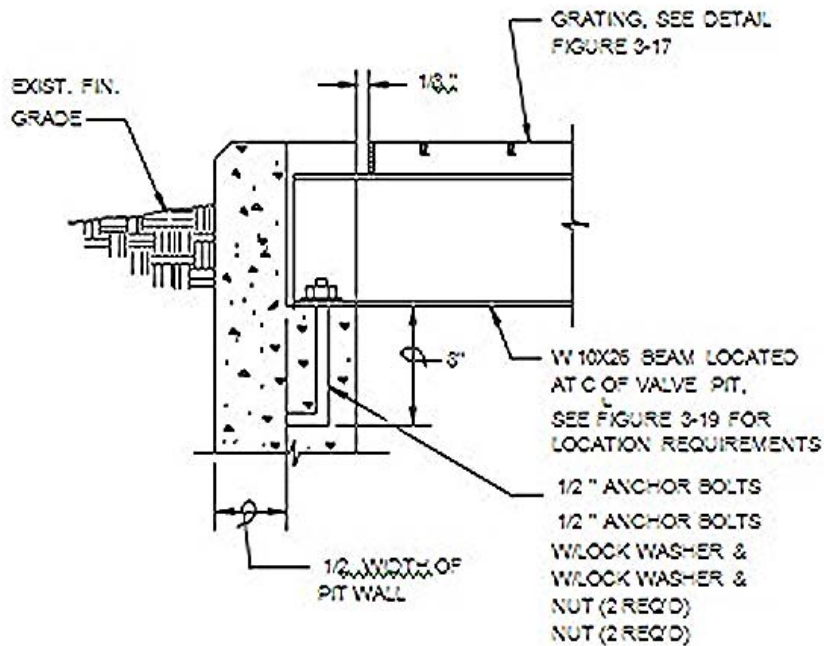

STRUCTURAL SUPPORT FOR GRATING

Figure 3-16

GRATING SUPPORT STEEL			
VALVE M.H. PLAN	WIDTH (ft)	LENGTH (ft)	REMARKS
A	4 OR LESS	AS REQD	NO MEMBER REQD
B	GREATER THAN 4 NOT TO EXCEED 12	AS REQD NOT TO EXCEED 12	ONE MEMBER REQD
C	GREATER THAN 12 NOT TO EXCEED 18	GREATER THAN 12 NOT TO EXCEED 18	THREE MEMBERS REQD

NOTE:
 1. FOR VALVE MANHOLE WITH DIMENSIONS L & W GREATER THAN 18 FEET REQUIRES STEEL MEMBERS AND GRATING TO BE DESIGNED FOR UNIFORM LOADS OF 40 PSF.
 2. ALL REEFING AND STEEL MEMBERS MUST BE DESIGNED FOR LOADING AND DIMENSIONS INDICATED.

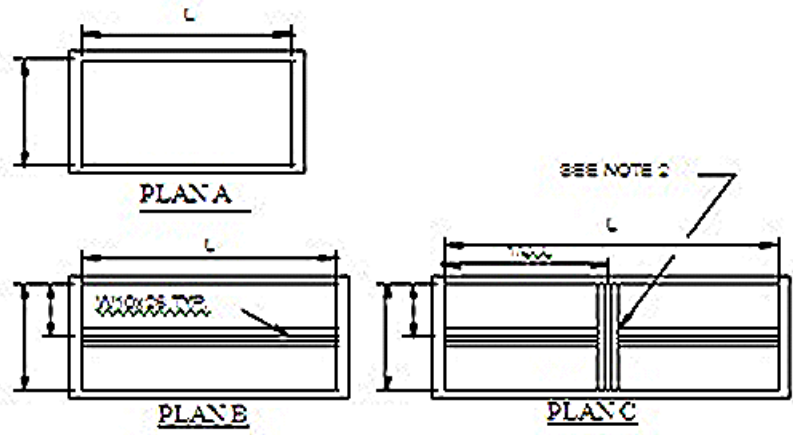

GRATING SUPPORT STEEL LOCATIONS
 NO SCALE

Figure 3-17

NOTE: PROVIDE A MINIMUM OF 4 CONNECTIONS PER PANEL. CONNECTIONS SHALL BE 4" MIN. FROM EDGES OF PANELS AND 1/4" FROM ENDS OF BEAMS.

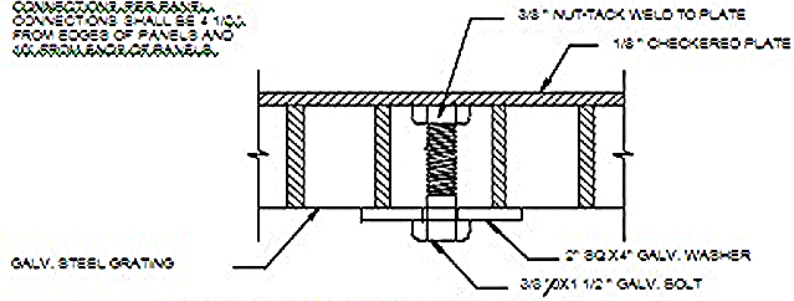

CONNECTION FOR ATTACHING CHECKERED PLATE TO GRATING

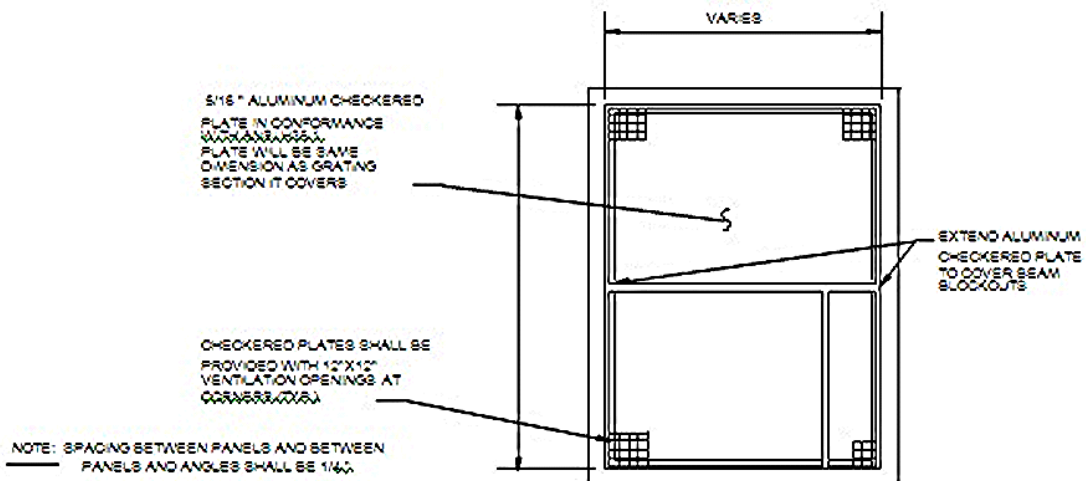

OPEN GRATE COVER W/CHECKER PLATE

CHECKER PLATE COVER DETAILS

NO SCALE

Figure 3-18

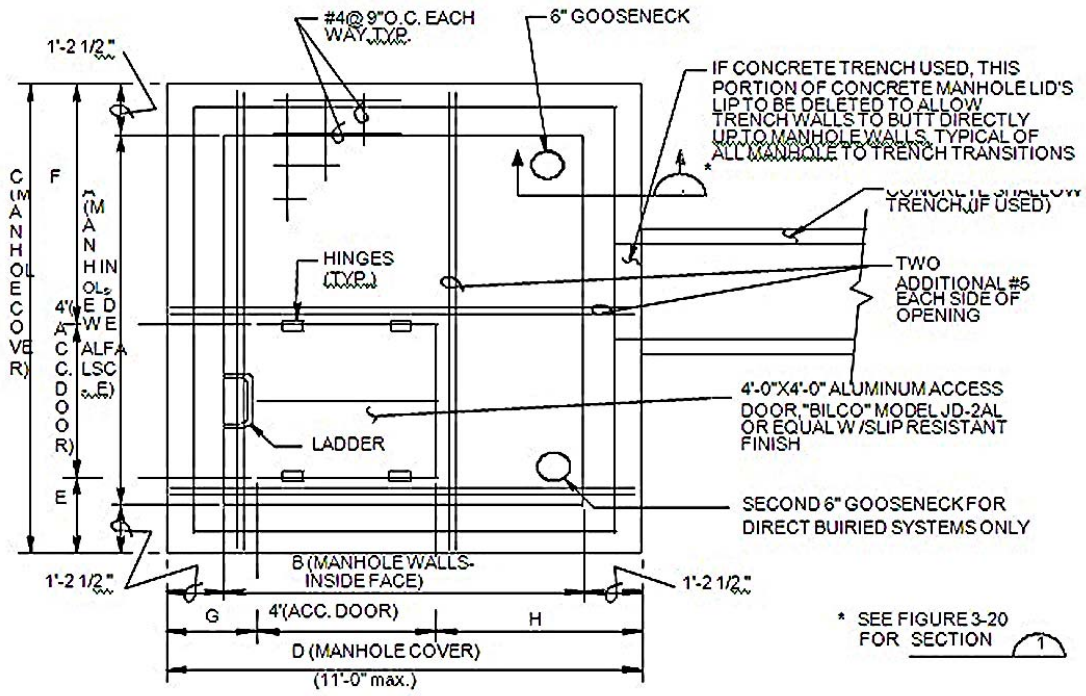

CONCRETE COVER PLAN

NO SCALE

Figure 3-19

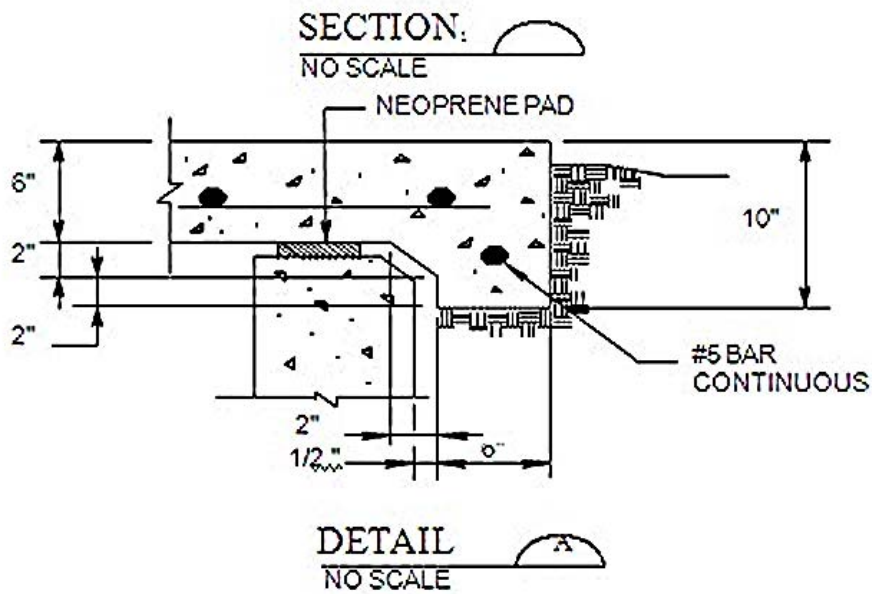
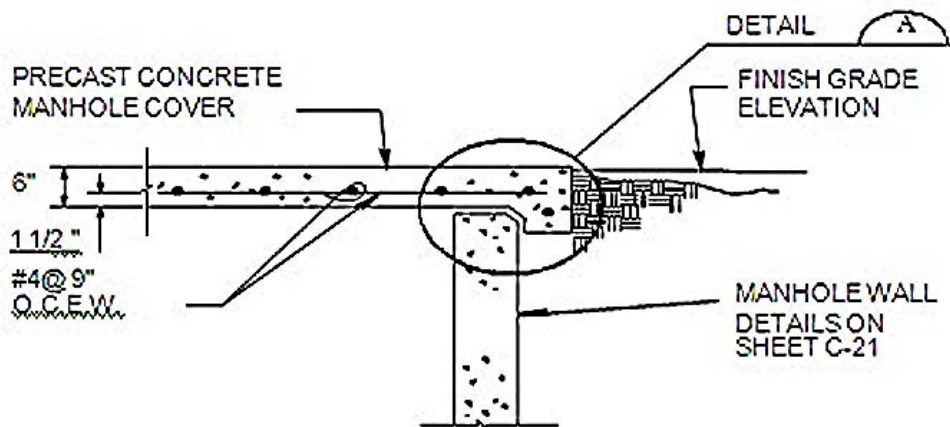

CONCRETE COVER DETAILS

Figure 3-20

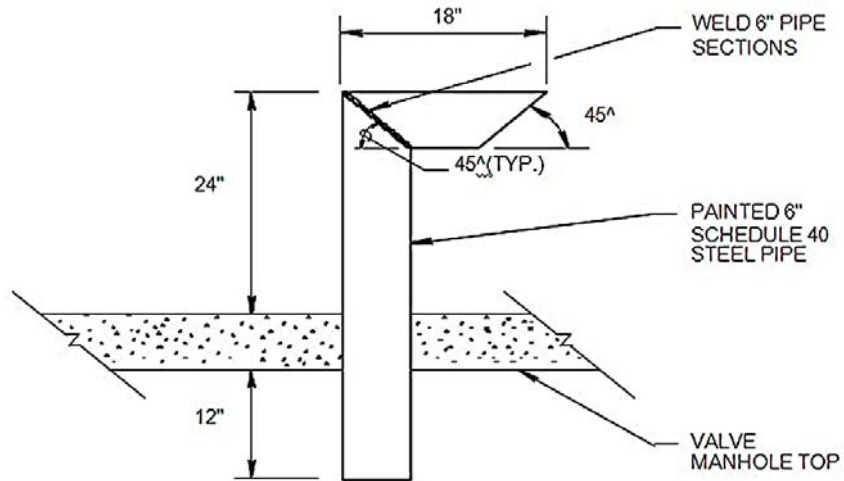

TYPICAL GOOSENECK DETAIL

Figure 3-21

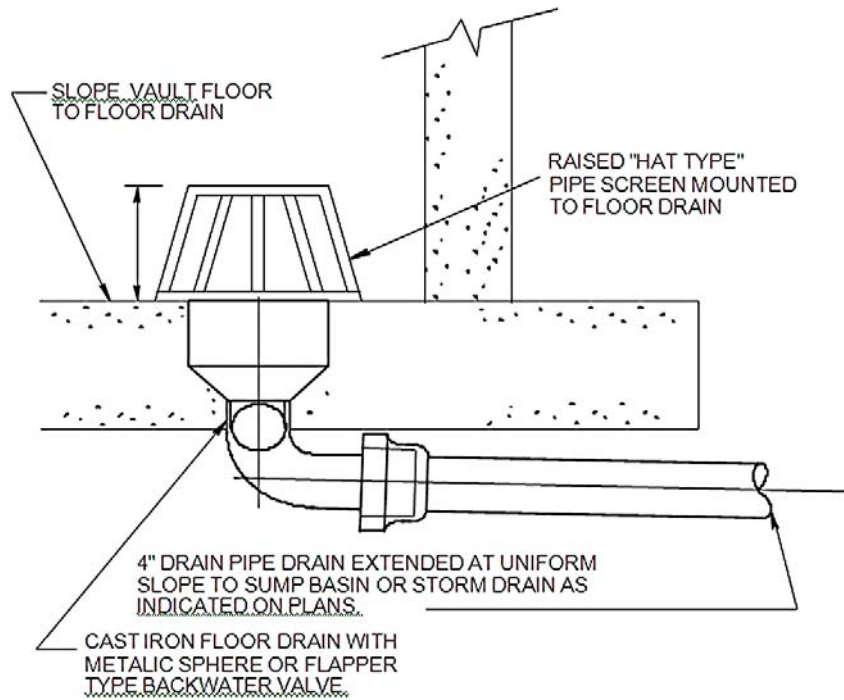

VALVE MANHOLE FLOOR DRAIN

Figure 3-22

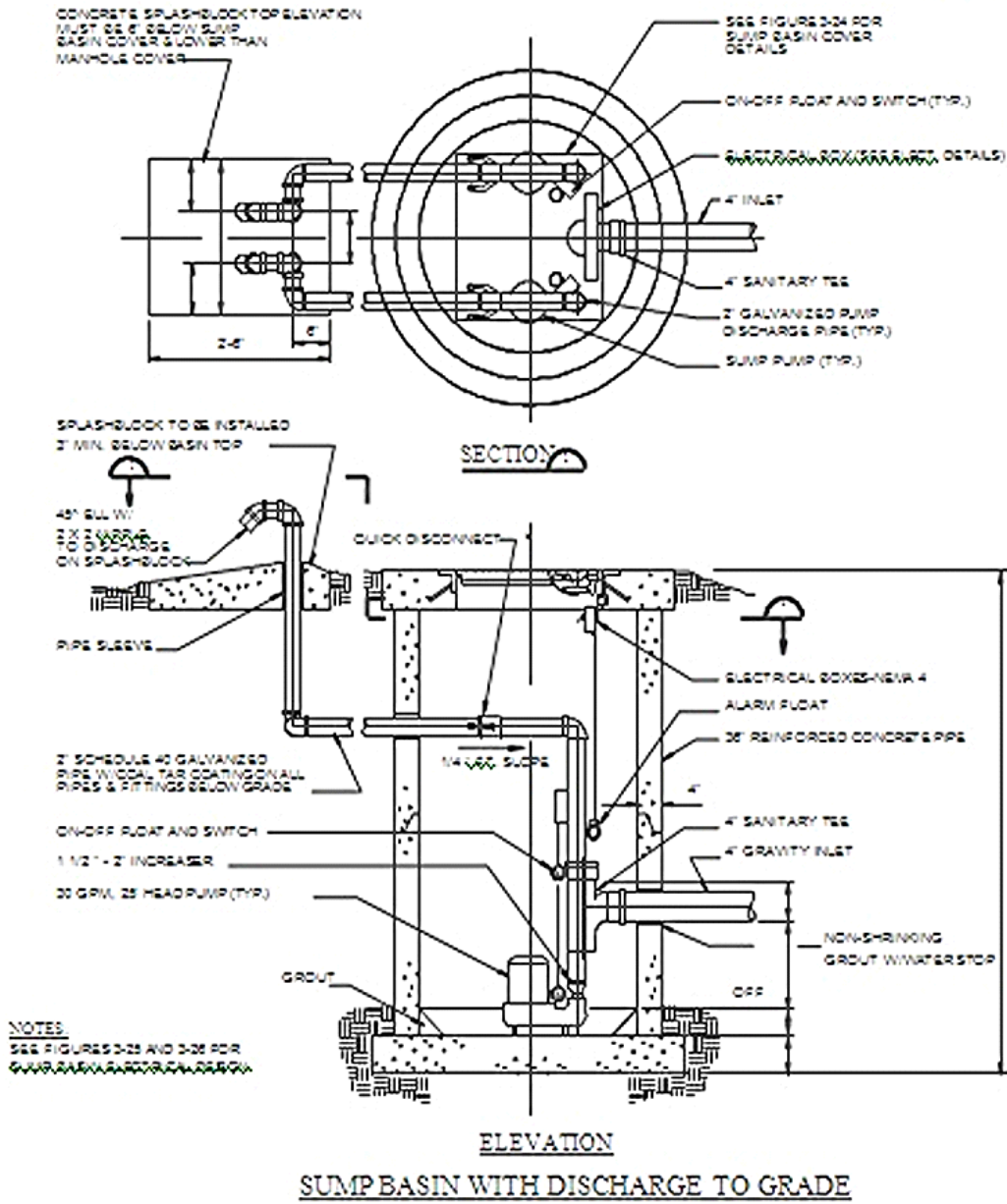

Figure 3-23

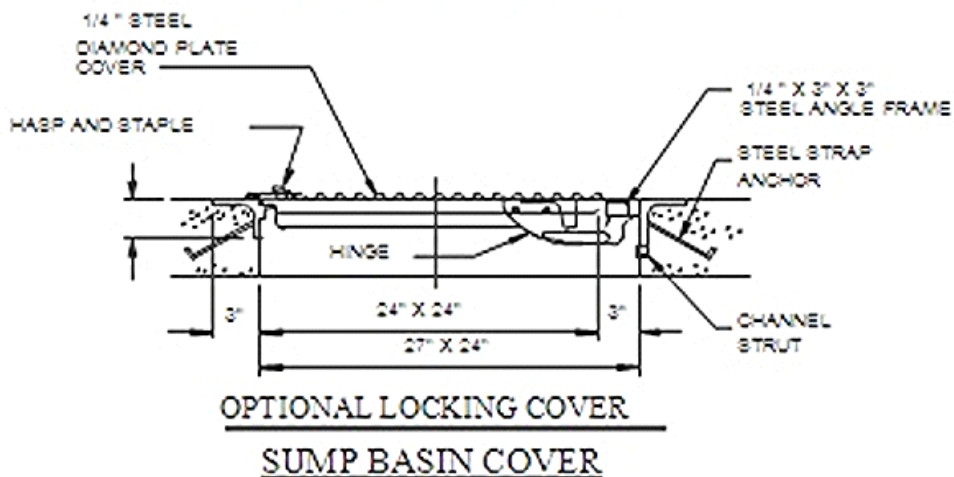
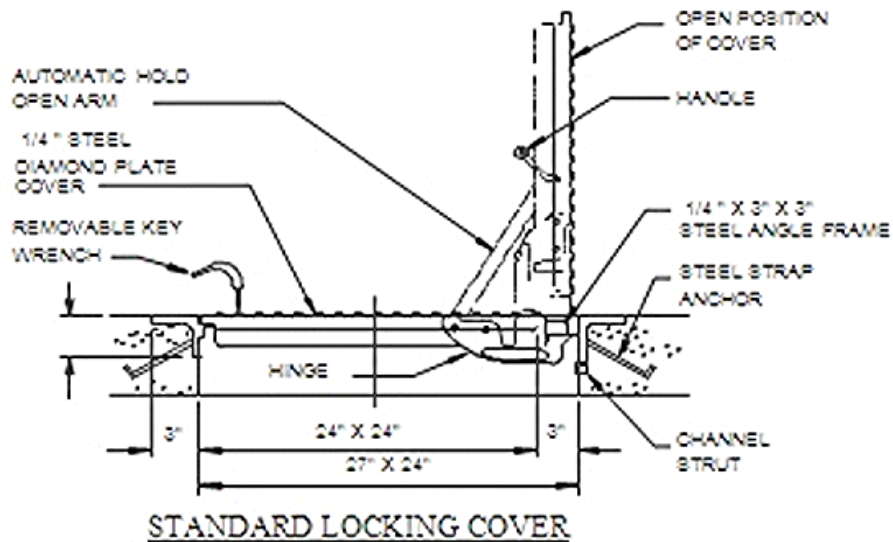
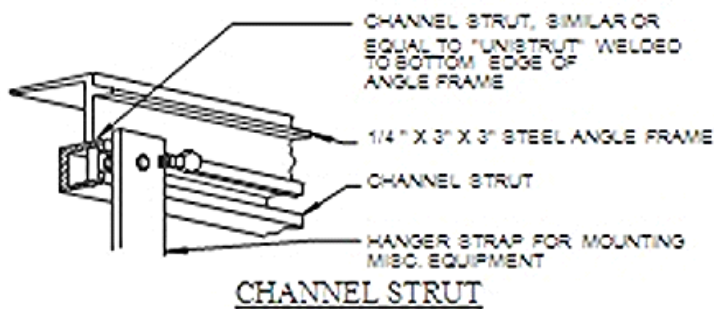
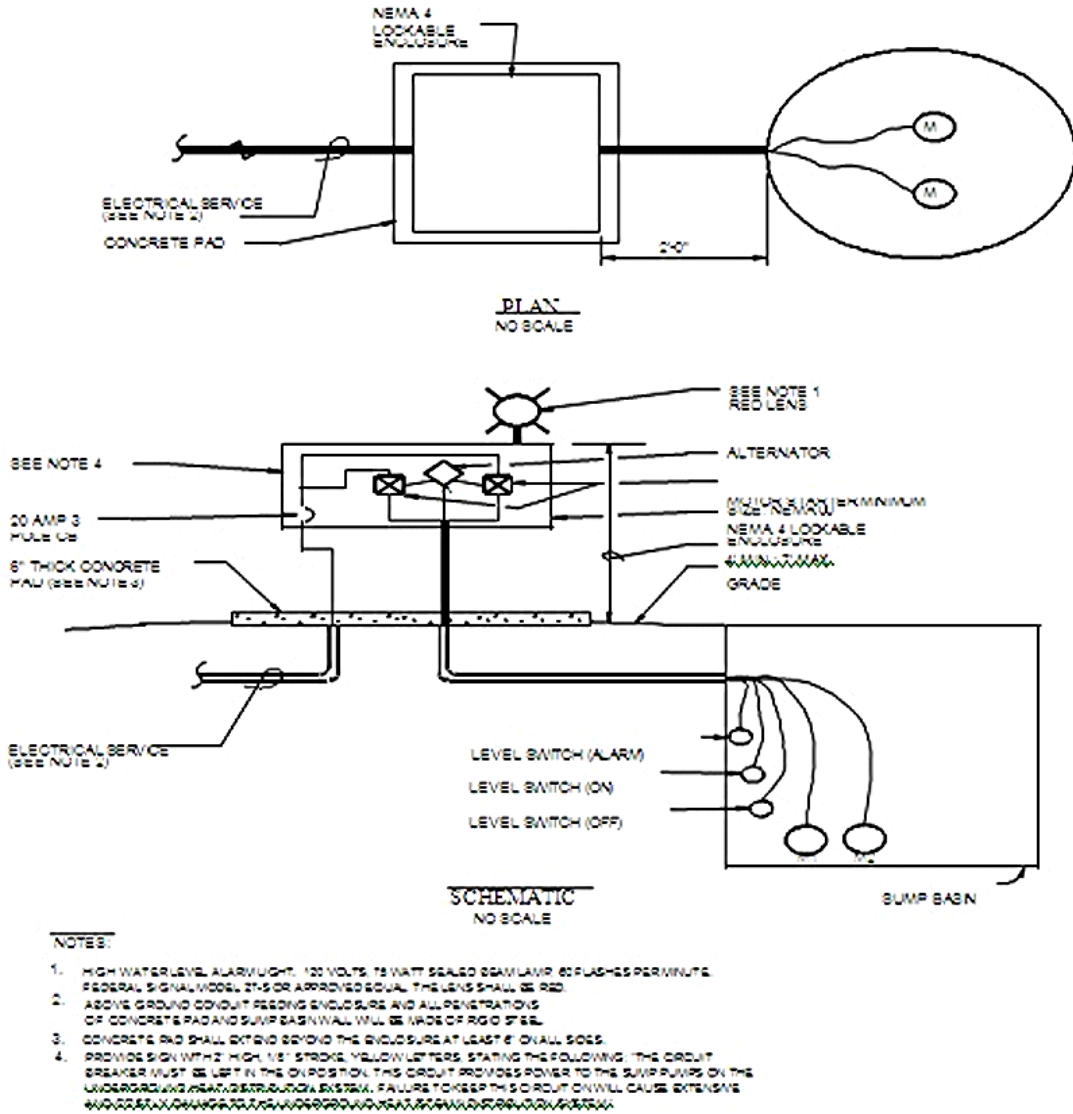
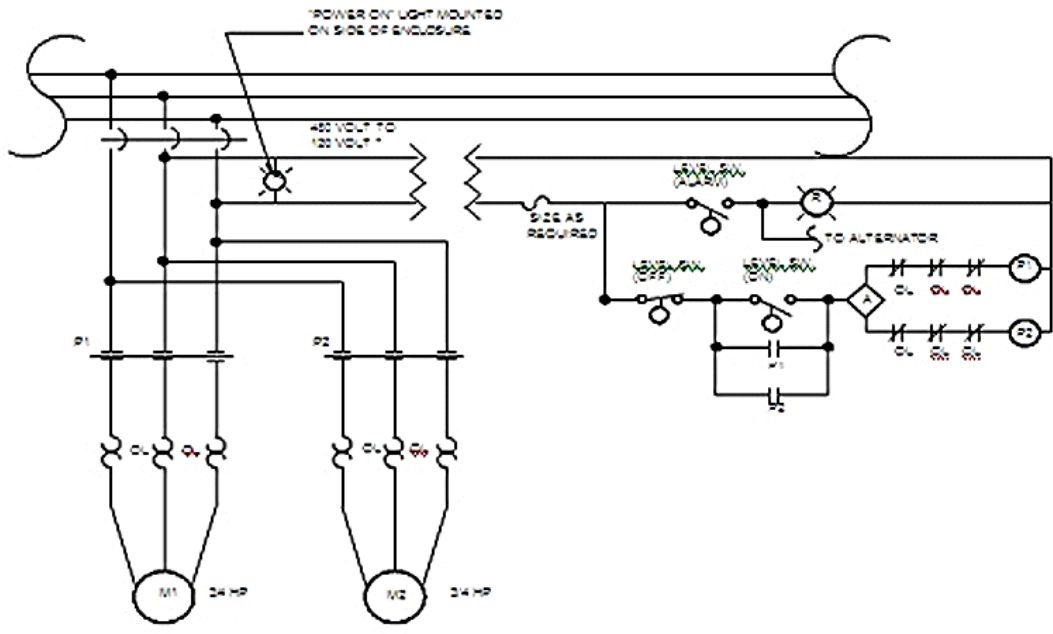

Figure 3-24



SUMP BASIN ELECTRICAL DETAILS

Figure 3-25



SEQUENCE OF OPERATION:

THE ALTERNATOR SHALL OPERATE A PUMP UPON WATER LEVEL REACHING LEVEL SWITCH ON AND DEENERGIZE IT WHEN THE WATER LEVEL FALLS BELOW LEVEL SWITCH OFF. IT SHALL ALTERNATE PUMPS ON EACH SUCCESSIVE CLOSING OF LEVEL SWITCH ON. IF THE WATER CONTINUES TO RISE PAST THE ALARM LEVEL THE RED LIGHT SHALL BE ENERGIZED AND THE 2ND (SECOND) PUMP

SUMP PUMP CONTROL-3 LINE DIAGRAM

NO SCALE

NOTE TO THE DESIGNER:

ACTUAL SYSTEM VOLTAGE AND HORSE POWER REQUIREMENTS MUST BE VERIFIED AND DETAILED FOR EACH DESIGN

Figure 3-26

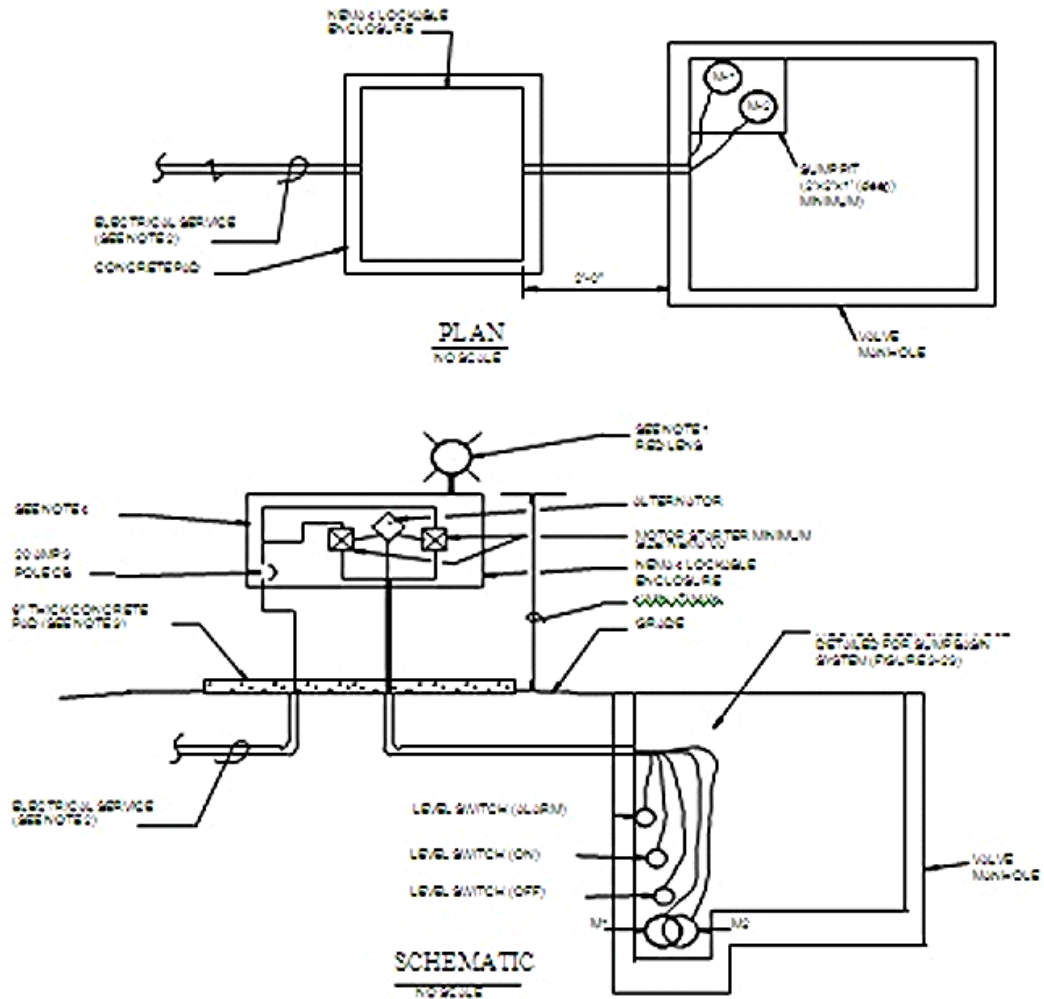

VALVE MANHOLE SUMP ELECTRICAL DETAILS

Figure 3-27

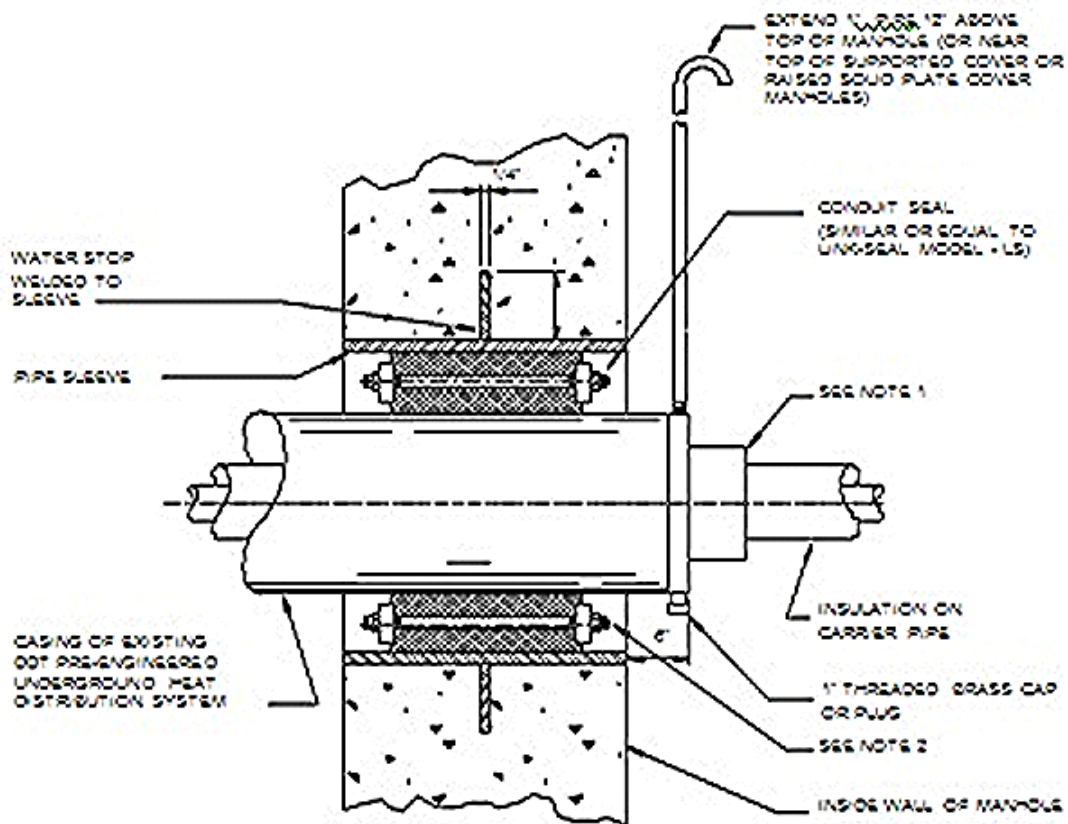

NOTES:

1. END SEAL OR GLAND SEAL SHALL BE PROVIDED ON ALL OUT PRE-ENGINEERED BURY SYSTEMS INSIDE MANHOLE WALLS. CASING AIR SPACE SHALL BE VENTED TO THE EXTERIOR. VENT SHALL HAVE 1" PIPE ROUTED AS INDICATED.
2. INSIDE DIAMETER (ID) OF SLEEVE SHALL BE DETERMINED AFTER CASING OUTSIDE DIAMETER (OD) HAS BEEN DETERMINED. GENERALLY, SLEEVE (ID) SHALL BE 5" MORE THAN CASING OD. VERIFY WITH SEAL MANUFACTURER.

CASING WALL PENETRATION
NO SCALE

Figure 3-28

RECOMMENDED INTERNAL CLEARANCES					
MINIMUM DISTANCE (INCHES) FROM TO	O.D. OF PIPE INSULATION OR CONDUIT	END OF VALVE STEM OR BODY	ELEC. EQUIP.	LADDER	BOTTOM OF TRAP STATION OR DRAIN
WALL	18"	18"	-	6"	18"
FLOOR	24"	24"	35"	12"	12"
TOP OF MANHOLE	18"	12"	6"	6"	35"

NOTES:

1. IN ADDITION TO THE CLEARANCES FOR THE LADDER INDICATED PROVIDE 24" AROUND THE LADDER FOR MAINTENANCE ACCESS.
2. PROVIDE 24" AROUND SIDES OF MANHOLE DRAIN TO ALLOW FOR CLEANING OF DEBRIS.

VALVE MANHOLE CLEARANCES

Table 3-1

VALVE MANHOLE REINFORCEMENT SCHEDULE							
MAXIMUM DIMENSION*		WALL REINFORCEMENT		SLAB REINFORCEMENT			
OUTSIDE L1XW1	INSIDE L2XW2	HORIZONTAL	VERTICAL	BOTTOM PRINCIPAL	TOP** PRINCIPAL	BOTTOM SECONDARY	TOP SECONDARY
9'4"X9'4"	8'0"X8'0"	#5@10"	#5@12"	#4@18"	#5@10"	#4@18"	#4@18"
15'4"X15'4"	14'0"X14'0"	#5@6"	#5@10"	#4@18"	#5@10"	#4@18"	#4@18"

NOTES TO THE DESIGNER:

* L1,L2,W1, AND W2 DIMENSIONS FROM FIGURE 3-5. MAXIMUM DEPTH (H1) FOR THIS TABLE IS 8'0"

** PRINCIPAL REINFORCEMENT WILL SPAN THE SHORTER DIMENSION

REINFORCED CONCRETE DESIGN IS BASED ON THE FOLLOWING:

1. LOADS : 200 psf SURCHARGE ADJACENT TO VAULT.
2. SOIL PROPERTIES = MOIST = 120 pcf WATER TABLE 2' BELOW SURFACE
SATURATED = 125 pcf BEARING CAP. = 1500 psf. MIN.
Ko = .80

REINFORCING STEEL SIZES

Table 3-2

SUMP PUMP CHECKLIST

<u>ITEM</u>	<u>PUMPS' DESCRIPTION</u>
1.	ELECTRICALLY DRIVEN.
2.	DUPLEX SYSTEM WITH ALTERNATOR.
3.	DEDICATED ELECTRICAL SERVICE.
4.	SUBMERGED OPERATION IN 200°F WATER.
5.	ENTIRE PUMPING SYSTEM CAPABLE OF 200,000 CYCLES OF OPERATION IN 200°F, 100% RELATIVE HUMIDITY ENVIR.
6.	PERMANENTLY LUBRICATED BEARINGS.
7.	BRONZE IMPELLER.
8.	MONEL SHAFT.
9.	CAPABLE OF PASSING 3/8 INCH SPHERES.
10.	SCREENED INLET.
11.	BRONZE HOUSING.

Table 3-3