Design Considerations for a Hydronic Pump System

Course No: M06-020

Credit: 6 PDH

A. Bhatia



Continuing Education and Development, Inc.
9 Greyridge Farm Court
Stony Point, NY 10980

P: (877) 322-5800

F: (877) 322-4774

info@cedengineering.com

Design Considerations for a Hydronic Pumping System

Abstract

In a pumping system, the objective, in most cases, is either to transfer a liquid from a source to a required destination, e.g. filling a high level reservoir, or to circulate liquid around a system for heat transfer. A pressure is needed to make the liquid flow at the required rate and this must overcome head 'losses' in the system. Losses are of two types: static and friction head. Most systems have a combination of static and friction head.

The most common application for hydronic (water) pumps is for fresh/raw water supply, process heat exchangers/boilers, cooling & chilled water systems, heating and steam systems, wastewater treatment and drainage. Although many pump types are available to the designer, the most common type of pump is the centrifugal pump. Among centrifugal pumps, there are many styles: single or double suction, in line or base mounted, close or flexible coupled and vertical turbine pumps. All have their specific uses and wide overlap. So in many applications, more than one pump style could be used. However in general:

1. Higher flow rates are better served by double suction pump in which axial forces tend to balance one another.
2. In line mounted pumps range from very small, fractional horsepower circulators to large pumps capable of handling several thousand GPM.
3. Close couple pumps are more compact than flexible coupled pumps, but they require motors with special faces that can be bolted up to the pump mounting bracket and longer shafts for mounting the impeller.
4. Vertical split casing, double suction pumps might serve best where the installation footprint plus the access space required to service the pump is tight.
5. Using a vertical turbine pump is a way to avoid suction lift situation that can be difficult for a standard centrifugal pump. For example, a vertical turbine pump is particularly well suited to application such as a cooling tower in which water from a tower basin must be elevated to the condenser and then to the tower.

Before we jump to system design opportunities, let's refresh few fundamentals. Don't bother on the sequence of listing; concepts get clear as you proceed.

Sno.	PUMP TERMINOLOGY
1	<p>Pump Energy Consumption</p> <p>The energy consumption of the pumps depend on two factors:</p> $\text{BHP} = \text{GPM} \times \text{TDH} \times \text{SG} / (3960 \times \text{Efficiency})$ <p>Where</p> <ul style="list-style-type: none"> • BHP = brake horse power • GPM = water flow, gallons per minute • TDH = Total Dynamic Head, feet • SG = Specific Gravity, for water it is 1 • Efficiency = Pump efficiency from its pump curves for the water flow and TDH <p>Power consumption, KWH = KW input x operating hours</p> <p>The KW input will depend on the motor efficiency and pump power requirement. (1 KW = 0.746 HP)</p>
2	<p>Pump Affinity Laws</p> <p>Effect on centrifugal pumps of change of speed or impeller diameter</p> <p>Capacity varies directly as the speed or impeller diameter (GPM x rpm x D)</p> <p>Head varies as the square of speed or impeller diameter (GPM x rpm² x D²)</p> <p>BHP varies as the cube of the speed or impeller diameter (BHP x rpm³ x D³)</p>
3	<p>What is head?</p> <p>The term head is commonly taken to mean the difference in elevation between the suction level and the discharge level of the liquid being pumped. Although this is partially correct, it does not include all of the conditions that should be included to give an accurate description.</p>
4	<p>What is suction lift?</p>

Sno.	PUMP TERMINOLOGY
	<p>A Suction Lift exists when the liquid level is below the centerline of the pump suction.</p> <p>The term static suction lift is used to describe the vertical distance from the pump centerline down to the free level of the liquid source below the pump.</p> <p>Typically, atmospheric pressure limits vertical suction lift of pumps to 25 feet at sea level. This does not mean that you are limited to 25 feet of pipe, you could use upwards of 300 feet of suction pipe, so long as the liquid source is not lower than 25 feet below the pump centerline.</p>
5	<p>What is suction head?</p> <p>The static suction head exists if the liquid source is located above the centerline of the pump. This may also be referred to a flooded suction.</p> <p>The term static suction head is used to describe the vertical distance from the centerline of the pump up to the free level of the liquid source above the pump.</p>
6	<p>What is dynamic suction lift?</p> <p>The dynamic suction lift includes static suction lift, friction head loss and velocity head.</p>
7	<p>What is dynamic suction head?</p> <p>The dynamic suction head includes static suction head minus friction head and velocity head.</p>
8	<p>What is Static Head?</p> <p>Static head is simply the difference in elevations of the outlet vs. the inlet point of the system or height of the supply and destination reservoirs. The static head is the potential energy of the system. Static head is independent of flow and pipe diameter.</p>
9	<p>What is the friction head?</p> <p>Friction head is the energy loss due to resistance to fluid movement and is</p>

Sno.	PUMP TERMINOLOGY
	<p>proportional to the square of the flow rate, pipe diameter and viscosity. The Hazen William, Colebrook and Darcy equations are the most common method of calculating friction head. Friction head is expressed in lbs/sq inch (psi) or feet of liquid</p> <p><i>A closed loop circulating system without a surface open to atmospheric pressure, would exhibit only friction losses.</i></p>
10	<p>What is Discharge Head?</p> <p>This is the vertical distance that you are able to pump the liquid. Again say your pump is rated for a maximum head of 18 feet, this does not mean that you are restricted to 18 feet of pipe, you could use 300 feet, so long as the final discharge point is not higher than 18 feet above the liquid being pumped.</p>
11	<p>What is Dynamic head?</p> <p>The dynamic head includes the dynamic discharge head plus dynamic suction lift or minus dynamic suction head into one computation.</p>
12	<p>What is Total Head?</p> <p>Total Head is the difference between the head at the discharge vs. the head at the inlet of the pump. It is sum of discharge head, suction lift and friction loss.</p> <p>Total Head is a measure of a pump's ability to push fluid through a system. This parameter (with the flow) is a more useful term than the pump discharge head since it is independent of a specific system.</p> <p>The Total Head produced by a pump is independent of the nature of the liquid (i.e. specific gravity or density) as is the head in any part of the system.</p>
13	<p>What information is required to determine the Total Head of a pump?</p> <p>Flow rate through the pump and throughout the system.</p> <p>Physical parameters of the system: length and size of pipe, number of fittings and type, elevation of inlet and outlet.</p> <p>Equipment in the system: control valves, heat exchangers etc.</p>

Sno.	PUMP TERMINOLOGY
	Fluid properties: temperature, viscosity and specific gravity
14	<p>Is the head at the discharge side of the pump equal to the Total Head?</p> <p>No, the Total Head is the difference in head between the discharge and the suction.</p>
15	<p>What is Velocity head?</p> <p>Velocity head is the head needed to accelerate the liquid. Knowing the velocity of the liquid, the velocity head loss can be calculated by simple formula, $Head = V^2/2g$ in which g is acceleration due to gravity or 32.16 ft/sec. Velocity head difference is proportional to the difference in kinetic energy between the inlet and outlet of the system.</p>
16	<p>What is Specific Gravity?</p> <p>Specific gravity is direct ratio of any liquid's weight to the weight of water at 62°F. Water at 62°F weighs 8.33 lbs per gallon and is designated as 1.0 specific gravity. By definition, the specific gravity of a fluid is: $SG = P_F / P_W$</p> <p>Where P_F is the fluid density and P_W is water density at standard conditions.</p> <p>Example Specific Gravity of HCl = Weight of HCl / Weight of Water = 10.0 / 8.34 = 1.2</p>
17	<p>What is viscosity?</p> <p>Viscosity is the fluid property from which the resistance to movement can be evaluated. The higher the viscosity the more difficult it is to move the fluid. Viscous liquids tend to increase pump HP, reduce efficiency, reduce capacity and head and increase pipe friction.</p>
18	<p>What is the difference between head and pressure?</p> <p>To start, head is not equivalent to pressure. Since the pump is a dynamic device, it is convenient to consider the head generated rather than the pressure. The term "Head" is usually expressed in feet whereas pressure is usually expressed in pounds per square inch. The relationship between two is</p>

Sno.	PUMP TERMINOLOGY
	<p>PSI = Head (feet) x Specific Gravity / 2.31</p> <p>The pump generates the same head of liquid whatever the density of the liquid being pumped.</p> <p>In the following equation (Bernoulli's equation) each of the terms is a head term: elevation head h, pressure head $\frac{p}{\gamma}$ and velocity head $\frac{v^2}{2g}$. Head is equal to specific energy, of which the units are lbf-ft/lbf. Therefore, the elevation head is actually the specific potential energy, the pressure head, the specific pressure energy and the velocity head is the specific kinetic energy (specific means per unit weight).</p> <p>$H + \frac{p}{\gamma} + \frac{v^2}{2g} = E = \text{Constant}$</p> <p>Where</p> <ul style="list-style-type: none"> • h: elevation; • p: pressure; • γ: fluid specific weight • v: velocity; • g: acceleration due to gravity (32.17 ft/s²); • E: specific energy or energy per unit mass. <p>Note: A centrifugal pump develops head not pressure. All pressure figures should be converted to feet of head taking into considerations the specific gravity.</p>
19	<p>What is vapor pressure?</p> <p>Vapor pressure denotes the lowest absolute pressure witnessed with a given liquid at a given temperature. If the pressure in a pump system is not equal to or greater than the vapor pressure of the liquid, the liquid will flash into a gas. It is for this same reason that we must have pressure available on the suction side of a pump when handling hot water or volatile liquids such as gasoline. Without sufficient pressure, the liquid will flash into a gas and cannot be pumped.</p>

Sno.	PUMP TERMINOLOGY
	<p>Many process applications use pressurized vessels on the suction side to overcome vapor pressure of some liquids. The amount of pressure needed depends on the liquid and liquid temperature. The higher the temperature, the higher shall be the vapor pressure. On applications involving an aboveground or underground-vented tank or a sump, care must be taken when handling volatile liquids to keep within the atmospheric pressure limitations.</p> <p>Consider for example a liquid that has a vapor pressure of 6 lbs absolute. This means, that at least 6 lbs pressure is needed to maintain the liquid state. Since atmospheric pressure is 14.7 lbs (sea level), we have only 8.7 lbs left to cover suction static lift and friction besides internal pump losses.</p> <p>Note: Water boils at 212° F at sea level because its vapor pressure is 14.7 lbs at that temperature. Since atmospheric pressure does not exceed 14.7 lbs, there is no extra pressure to maintain liquid state</p> <p>Vapor pressure is measured in pound absolute. Absolute pressure is pressure above a perfect vacuum.</p>
20	<p>What is cavitation?</p> <p>If the incoming liquid is at a pressure with <u>insufficient</u> margin above its vapor pressure, then vapor cavities or bubbles appear along the impeller vanes. This phenomenon is known as cavitation and has three undesirable effects:</p> <ol style="list-style-type: none"> 1. The collapsing cavitation bubbles can erode the vane surface, especially when pumping water-based liquids. 2. Noise and vibration are increased, with possible shortened seal and bearing life. 3. The cavity areas will initially partially choke the impeller passages and reduce the pump performance. In extreme cases, total loss of pump-developed head occurs.
21	<p>What is relative and absolute pressure?</p> <p>A pressure measurement that is absolute is not related to any other. The atmospheric pressure at sea level is 14.7 psia (pounds per square inch</p>

Sno.	PUMP TERMINOLOGY
	<p>absolute), that is, 14.7 psi above zero absolute. Relative pressure is always related to the local atmospheric pressure. For example, 10 psig (pound per square inch gauge) is 10 psi above the local atmospheric pressure. Most pressure measurements are taken in psig, which is relative to the local pressure. Pressure measurements do not normally have to be corrected for altitude, since all the measurements you might do on a system are relative to the same atmospheric pressure therefore the effect of elevation is not a factor. An important exception to this is when taking a pressure measurement at the pump suction to determine the N.P.S.H. available. This pressure measurement is converted to absolute pressure, which should be corrected for altitude.</p>
22	<p>What information do I need to select a pump?</p> <ul style="list-style-type: none"> a) GPM... (Flow); b) Total discharge head (Push in PSI or ft) b) Suction lift... (Pull); d) Friction... (Resistance) c) Temperature... (How hot); f) Viscosity ... (How thick) d) Liquid... (What liquid); h) Nature of Liquid... (Clear or with solids) e) Service factor... (Continuous or intermittent) f) Specific gravity... (Weight); k) Type of drive... (Motor- engine etc)
23	<p>What is N.P.S.H.?</p> <p>The Net Positive Suction Head (N.P.S.H.) is the pressure head at the suction flange of the pump less the vapor pressure converted to fluid column height of the fluid. The N.P.S.H. is always positive since it is expressed in terms of absolute fluid column height. The term "Net" refers to the actual pressure head at the pump suction flange and not the static head. The N.P.S.H. is independent of the fluid density as are all head terms.</p> <p>What is the difference between the N.P.S.H. available and the N.P.S.H. required?</p> <p>The value, by which the pressure in the pump suction exceeds the liquid vapor pressure and is expressed as a head of liquid and referred to as Net Positive</p>

Sno.	PUMP TERMINOLOGY
	<p>Suction Head Available – (NPSHA). This is a characteristic of the suction system design. It can be calculated for a specific situation and depends on the barometric pressure, the friction loss between the system inlet and the pump suction flange, and other factors.</p> <p>The value of NPSH needed at the pump suction to prevent the pump from cavitating is known as NPSH Required – (NPSHR). This is a characteristic of the pump design. The N.P.S.H. required refers to the internal pump losses and is determined by laboratory test. It varies with each pump and with each pump capacity and speed change.</p> <p>Since there are also internal pump losses (required NPSH) the available NPSH in a system must exceed the pump required NPSH- otherwise reduction in capacity, loss of efficiency, noise, vibration and cavitation will result. <u>The N.P.S.H. available must always be greater than the N.P.S.H. required for the pump to operate properly.</u></p> <p>As would be expected, the NPSHR increases as the flow through the pump increases. In addition, as flow increases in the suction pipe work, friction losses also increase, giving a lower NPSHA at the pump suction, both of which give a greater chance that cavitation will occur. NPSHR also varies approximately with the square of speed in the same way as pump head and conversion of NPSHR from one speed to another can be made using the following equations. It is therefore essential to carefully consider NPSH in variable speed pumping.</p>
24	<p>How is NPSH computed?</p> <p>To determine the NPSH available in a proposed application, the following formula may be used</p> $H_{sv} = H_p \pm H_z - H_f - H_{vp}$ <p>Where</p> <ul style="list-style-type: none"> • H_{sv} = Available NPSH expressed in feet of fluid • H_p = Absolute pressure on the surface of the liquid where the pump takes suction, expressed in feet. This could be atmospheric

Sno.	PUMP TERMINOLOGY
	<p>pressure or vessel pressure (pressurized tank). It is a positive factor</p> <ul style="list-style-type: none"> • H_z = Static elevation of the liquid above or below the centerline of the impeller, expressed in feet. Static suction head is positive factor while static suction lift is a negative factor. • H_f = Friction and velocity head loss in the piping, also expressed in feet. It is a negative factor. • H_{vp} = Absolute vapor pressure of the fluid at the pumping temperature, expressed in feet of liquid. It is a negative pressure.
25	<p>Is the head at the suction side of a pump equal to the N.P.S.H. available?</p> <p>No, the N.P.S.H. available is the head in absolute fluid column height minus the vapor pressure (in terms of fluid column height) of the fluid. Close, but different.</p>
26	<p>How is the pressure drop established for a control valve?</p> <p>10 ft of pressure drop is a common value used in designing systems with control valves. This criterion will generally result in a valve size one size smaller than the line (i.e. if the line is 8", the valve is 6"). When designing a new system, if we assume a pressure drop across the valve of 10 ft of fluid, then it will be generally possible to select a valve that will give this pressure drop at a reasonable opening of say 90%.</p> <p>In the case of existing systems where the control valve is in place, we should be more careful. While the system is operating, the position of the valve should be noted. The manufacturer's tables for this valve will give the pressure drop corresponding to the flow rate and valve opening. This pressure drop should be used in the calculations for Total Head.</p>
27	<p>How is the pressure head at any location in a piping system determined and why it is important?</p> <p>First, calculate the Total Head of the system. Then, using a control volume set</p>

Sno.	PUMP TERMINOLOGY
	<p>one limit at the point where the pressure head is required and the other at the inlet or outlet of the system. Apply an energy balance and convert all energy terms to head. The resulting equation gives the pressure head at the point required.</p> <p>Why bother? The most common reason for this calculation is to establish the pressure ahead of a control valve, which is required to size the valve.</p>
28	<p>What are the consequences of improper pump selection?</p> <p>The complexity associated with selecting a pump often results in a pump that is improperly sized for its application. Selecting a pump that is either too large or too small can reduce system performance. Under sizing a pump may result inadequate flow, failing to meet system requirements. An oversized pump, while providing sufficient flow, can produce other negative consequences:</p> <ul style="list-style-type: none"> • Higher purchase costs for pump and motor assembly • Higher energy costs, because oversized pumps operate less efficiently and <p>Higher maintenance requirements, because as pumps operate further from their BEP they experience greater stress</p>
29	<p>What is a performance curve?</p> <p>A performance curve is a plot of Total Head vs. flow rate for a specific impeller diameter. The plot starts at zero flow. The head at this point corresponds to the “shut-off head” of the pump. The curve then decreases to a point where the flow is maximum and the head minimum. This point is sometimes called the “run-out point”. Beyond this, the pump cannot operate. The pump's range of operation is from point shut off head to run out point. In general</p> <ul style="list-style-type: none"> • Higher Head = Lower Flow • Lower Head = Higher Flow • Lower Flow = Lower Horsepower • Higher Flow = Higher Horsepower

Sno.	PUMP TERMINOLOGY
30	<p>What is the Best Efficiency Point (B.E.P.)?</p> <p>The B.E.P. (best efficiency point) is the point of highest efficiency of the pump. All points to the right or left of B.E.P have a lower efficiency. The impeller is subject to non-symmetrical forces when operating to the right or left of the B.E.P. These forces manifest themselves as vibration depending on the speed and construction of the pump. The most stable area is near or at the B.E.P.</p>
31	<p>Why efficient pump control is important?</p> <p>In systems with highly variable loads, pumps that are sized to handle the largest loads may be oversized for normal loads. Ironically, many oversized pumps are purchased with the intent of increasing system reliability or considering future demands. Unfortunately, conservative practices often prioritize initial performance over system life cycle costs. As a result, larger than necessary pump are specified, resulting in systems that do not operate optimally. In systems that experience wide variations in demand, system efficiency depends on configuring a pump or set of pumps so that the efficiency remains high over the range of operating conditions.</p> <p>Selecting a centrifugal pump can be challenging because these pumps generate different amounts of flow at different pressures. Each centrifugal pump has a “best efficiency point” (BEP). Ideally, under normal operating conditions, the required flow rate will coincide with the pump’s BEP.</p>
32	<p>How can a pump satisfy different flow requirements of a system?</p> <p>If a pump is sized for a greater flow and head that is required for the present conditions, then a manual valve at the outlet of the pump can be used to throttle the flow down to the present requirements. Therefore, at a future date simply opening a valve can increase the flow. The other most frequent means of reducing the output flow rate is to have a line which re-circulates flow back to the suction tank. Either method works well, but there is a penalty to be paid in consumption of extra power for running a system, which is oversized for the normal demand flow rate.</p> <p>The use of multiple pumps, multiple speed motors or variable speed drives</p>

Sno.	PUMP TERMINOLOGY
	often improves system performance over the range of operating conditions.
33	<p>What are multiple pump configurations?</p> <p>To handle wide variation in flow, multiple pumps are often used in parallel configuration. This arrangement allows pumps to be energized and de-energized to meet system needs. One way to arrange pumps in parallel is to use two or more pumps of the same type. Alternatively, pumps with different flow rates can be installed in parallel and configured such that the small pump – often referred to as the ‘pony pump’ operates during normal conditions while the larger pump operates during periods of high demand.</p>
34	<p>What is the purpose of a variable speed drive?</p> <p>Speed control is an option that can keep pumps operating efficiently over a broad range of flows. In centrifugal pumps, speed is linearly related to flow but has a cube relationship with power. For example, slowing a pump from 1800 to 1200 rpm results in a 33% decreased flow and a 70% decrease in power. This also places less stress on the system. For a new installation this alternative should be considered. This provides the same flow control as a system with a control valve without the energy waste.</p>
35	<p>How does a variable speed drive work?</p> <p>The head and flow produced by a pump is the result of centrifugal force imparted to the liquid by the impeller. The centrifugal force acting on the fluid is directly proportional to impeller diameter and rotational speed. We can affect the centrifugal force by either changing the impeller diameter, which is difficult and permanent, or by varying the impeller speed, which of course is what a variable speed drive does.</p> <p>If we keep the impeller size constant and vary the speed of the pump, a similar set of curves for different pump speeds is produced. When a variable speed drive is used, only the required pump head and flow is produced resulting in appropriate power consumption.</p>
36	Variable Speed Drive Considerations

Sno.	PUMP TERMINOLOGY
	<p>The selection of the motor for a variable speed drive application should consider the torque available at the operating speed of the pump. For example, if the motor base speed is 1800 rpm and the speed required during the operation is not greater than 1500, depending on the motor design it is possible that the torque produced at 1500 rpm will be insufficient. In other words, the torque for certain motor designs are down rated for operating speeds less than the motor base speed. This may result in having to select a larger motor frame than the initial selection based solely on horsepower. It is prudent to obtain from the motor supplier the torque vs. speed curve for the proposed motor.</p>
37	<p>Is there limitation of Variable Speed Drive?</p> <p>For systems in which static head represents a large portion of the total head, VFD may be unable to meet system needs. The benefits may be limited.</p>
38	<p>What is specific speed of pump?</p> <p>The term impeller specific speed is used to classify impellers of various types based on their performance. Specific speed is defined as that speed at which a geometrically similar pump would deliver one unit of flow to one unit of head.</p> <p>This value tells us something about the type of pump. Is it a radial type pump, which provides high head and low flow or an axial or propeller type pump, which provides high flow but low head or something in between?</p> <p>There are varieties of pump designs that are available for any given task. Pump designers have needed a way to compare the efficiency of their designs across a large range of pump model and types. Pump users also would like to know what efficiency could be expected from a particular pump design. For that purpose pump have been tested and compared using a number or criteria called the specific speed (N_s), which helps to do these comparisons.</p> <p>Equation below gives the value for the pump specific speed;</p> $N_s = \frac{N(\text{rpm}) \times \sqrt{Q(\text{USgpm})}}{H(\text{ft fluid})^{0.75}}$

Sno.	PUMP TERMINOLOGY
	<p>Specific speed is a dimensionless quantity.</p> <p>Specific speed is indicative of the shape and characteristics of an impeller. Impeller form and proportions vary with specific speed but not the size. It can be seen that there is a gradual change in the profiles from radial to axial flow configuration.</p> <p>Studies indicate that a pump efficiency at the best efficiency point (BEP) depends mainly on the specific speed, and a pump with specific speed of 1500 is more efficient than the one with specific speed of 1000.</p> <p>Also if you are worried that your pump may be cavitating there is another number related to specific speed called suction specific speed that will help you diagnose and avoid cavitation.</p>
39	<p>What are different types of centrifugal pumps?</p> <p><u>Radial Flow</u> - a centrifugal pump in which the pressure is developed wholly by centrifugal force.</p> <p>Pumps with this type of impeller have very low specific speeds (up to approximately 1,150 [1,000]). The liquid enters the eye of the impeller and is turned by the impeller vanes and shroud to exit perpendicular to the axis of the pump shaft. Modified radial flow type usually has specific speed ranging from around 1,150 to 4,650 (1,000 to 4,000). The impellers are normally single suction. In pumps of this type, the liquid enters the impeller at the eye and exits semi-radially, at about a 60° to 70° angle with shaft axis.</p> <p><u>Mixed Flow</u> - a centrifugal pump in which the pressure is developed partly by centrifugal force and partly by the lift of the vanes of the impeller on the liquid. This type of pump has a single inlet impeller with the flow entering axially and discharging about 45° with shaft axis, to the periphery.</p> <p>Pumps of this type usually have a specific speed from 4,650 to 10,000 (4,000 to 9,000).</p> <p><u>Axial Flow</u> - a centrifugal pump in which the pressure is developed by the propelling or lifting action of the vanes of the impeller on the liquid. A pump of this type, also called a propeller pump, has a single inlet impeller with the flow</p>

Sno.	PUMP TERMINOLOGY
	<p>entering axially and discharging nearly axially.</p> <p>Pumps of this type usually have a specific speed above 10,000 (9,000). The axial flow pump propeller does not have a shroud. These are most suitable for high discharge; low head applications involving flood control etc.</p>
40	<p>What are different types of positive displacement pumps?</p> <p>The positive displacement pumps are categorized as single rotor or multiple rotor types. The further classification is as follows:</p> <p><u>Single Rotor</u></p> <p>Vane - The vane(s) may be blades, buckets, rollers or slippers, which cooperate with a dam to draw fluid into and out of the pump chamber.</p> <p>Piston - Fluid is drawn in and out of the pump chamber by a piston(s) reciprocating within a cylinder(s) and operating port valves.</p> <p>Flexible member - Pumping and sealing depends on the elasticity of a flexible member(s), which may be a tube, vane or a liner.</p> <p>Single screw - Fluid is carried between rotor screw threads as they mesh with internal threads on the stator.</p> <p><u>Multiple Rotor</u></p> <p>Gear - Fluid is carried between gear teeth and is expelled by the meshing of the gears, which cooperate to provide continuous sealing between the pump inlet and outlet.</p> <p>Lobe - Fluid is carried between rotor lobes, which cooperate to provide continuous sealing between the pump inlet and outlet.</p> <p>Circumferential Piston - Fluid is carried in spaces between piston surfaces not requiring contacts between rotor surfaces.</p> <p>Multiple Screw - Fluid is carried between rotor screw threads as they mesh.</p>
41	<p>What is the difference between centrifugal and positive displacement pumps?</p>

Sno.	PUMP TERMINOLOGY
	<p>Centrifugal pump is one that employs centrifugal force for pumping liquids. Liquid entering the eye (center) of the impeller is accelerated by the impeller vanes to a high velocity and is thrown out from the rotating vanes by centrifugal force into volute to the discharge.</p> <p>Positive Displacement Pumps can be classified into two main groups: Rotary and Reciprocating.</p> <p>Rotary pumps transfer liquid from suction to discharge through the action of rotating screws, lobes, gears, valves, and rollers etc, which operate inside a rigid casing.</p> <p>1. <u>Capacity (flow)</u></p> <p>Radial-flow and mixed flow pumps are suitable for low to medium capacity applications. For high capacity applications, axial-flow pumps are capable of delivering flow rates in excess of 100,000 GPM.</p> <p>Reciprocating and rotary pumps are capable of capacities ranging from low to medium, with flow rates peaking at ~10,000 GPM</p> <p>2. <u>Low Flow Capability</u></p> <p>Centrifugal pumps are not stable at low flow rates.</p> <p>Both reciprocating and rotary pumps can deliver extremely low flow rates (fractions of a GPM), making them particularly suitable for many chemical injection applications.</p> <p>3. <u>Pressures</u></p> <p>Centrifugal pumps and rotary pumps are best suited for low to medium pressure applications. Multi-stage centrifugal pumps can deliver pressures of ~6,000 psi and may be the most economical choice at this pressure in high capacity applications.</p> <p>Reciprocating pumps are usually specified for high-pressure service, with capabilities exceeding 100,000 psi. In most applications exceeding 1,000 psig, reciprocating pumps are more suitable, particularly in low to medium capacity service</p>

PUMP SYSTEM CHARACTERISTICS

A pump performance curve, often called simply a PUMP CURVE, shows the performance characteristics of a particular pump. Pump curve shows the relationship between pump capacity and pump head.

- As the capacity of the pump (gpm) increases, the pump head pressure (feet of head) decreases.
- As pump head increases, the pump capacity decreases.

Look at the typical pump curve below.

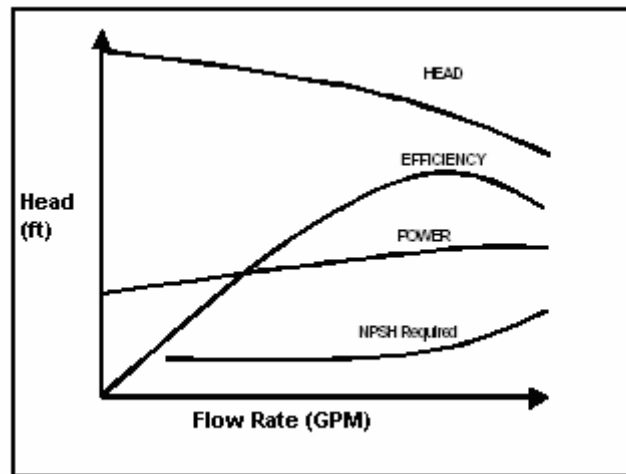

Typical Pump Performance Curve

Pressure vs. Flow

The performance of a pump varies depending on how much water the pump is moving and the pressure it is creating. This is an important relationship not only because it determines whether the pump is suitable for your system, but also because it is these pump characteristics which allow you to control the operation of your pump.

The primary relationship to understand is that as the flow INCREASES, the pressure DECREASES. Here are the standard formulas used to estimate flow, pressure, and horsepower for all electric pumps. Note: these formulas have been simplified to assume a pump efficiency of 55% which is a good average figure to work with if you don't know the exact efficiency of your pump. Pressure for pumps is always measured in feet of

head (in the U.S.A.); one foot of head is equal to 0.433 pounds per square inch. The formula is:

$$\text{FT.HD.} = \text{HP} \times 2178 / \text{GPM}$$

$$\text{GPM} = \text{HP} \times 2178 / \text{FT.HD.}$$

$$\text{HP} = \text{GPM} \times \text{FT.HD.} / 2178$$

HP is brake horsepower

GPM is gallons per minute of flow

FT.HD. is pressure in feet of head ($\text{PSI} \times 2.31 = \text{FT.HD.}$)

System Curves and Pump Curves

When a pump is installed in a system the effect can be illustrated graphically by superimposing pump and system curves. The operating point will always be where the two curves intersect. This operating condition must be located within the region in the curve so that a slight deterioration of head will improve the pump efficiency, not worsen it.

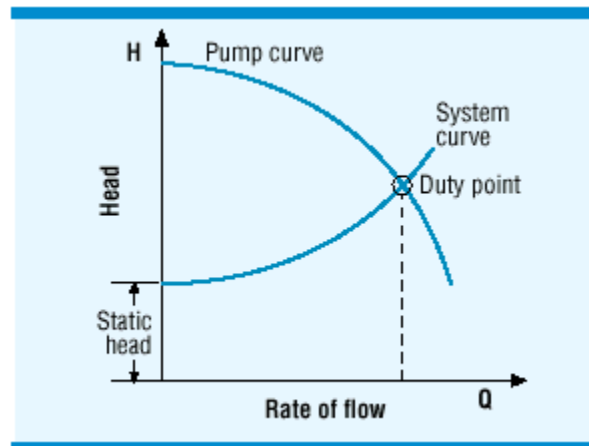

Rotodynamic Pump System Curve

A pump curve is the path that a pump has to operate on. In graph form, it tells us the performance of a pump in gallons per minute flow rate versus the head in feet. The curve is designed by the manufacturer and is based on the horsepower, the diameter of the impeller and the shape of its volute (the wet end of the pump that contains the impeller). No matter what the conditions of a system, the pump has to operate

somewhere on this curve. *When a piping system is made up primarily of vertical lift and very little pipe friction, the pump characteristic should be steep and when a piping system is made up primarily of friction head and very little of vertical lift, the pump characteristic should be near horizontal.*

System curves, on the other hand, represent the flow-head relationships that exist for particular installations. For any given system, once a design condition is calculated, you can establish other flow and head conditions by scaling the curve. The performance curve states "head will change as the square of the change in flow." For example, if you had a system pumping 5 GPM at 4' head loss and wanted to increase the flow rate to 10 GPM, the head loss would increase to 16' head. You can plot a system curve that is specific to a given system.

Usually it is advantageous to select the pump such that the system curve intersects the full speed pump curve to the right of best efficiency, in order that the efficiency will first increase as the speed is reduced (with variable speed drive) and then decrease.

Adding comfort margins to the calculated system curve to ensure that a sufficiently large pump is selected will generally result in installing an oversized pump, which will operate at an excessive flow rate or in a throttled condition, which increases energy usage and reduces pump life.

There are regions in the pump curve where the efficiency is lowest- these are the extremely high head condition and extremely low head condition. In the extremely high head condition, a slight increase in the head will cause the pump to surge, meaning a rapid no flow- high flow condition. In the extreme low head condition, this happens when there is a break in the line so that all resistance, hence the TDH, drops. These conditions must be avoided.

Pump System Design

Design systems with lower capacity and total head requirements. Do not assume these requirements are fixed.

The choice of a pump depends on the service needed from the pump. Considerations are flow and head requirements, inlet pressure or net positive suction head available, and the type of liquid to be pumped. Maximum attainable efficiency of a centrifugal pump is influenced by the designer's selection of pump rotating speed as it relates to

"specific speed." Purchasers need to be aware of this, as well as the decision criteria for determining the type of pump to use.

A pump installation is often sized to cope with a maximum predicted flow, which, may never happen. An efficient design shall carefully optimize the flow and head requirements. Flow capacity, for example, can be reduced through use of lower velocity in heat exchangers and elimination of open bypass lines.

Total head requirements can be reduced by: lowering process static gage, pressure, minimizing elevation rise from suction tank to discharge tank, reducing static elevation change by use of siphons, lowering spray nozzle velocities, lowering friction losses through use of larger pipes and low-loss fittings, and eliminating throttle valves.

The pumping power requirement for any system is fundamentally governed by the system flow need, head loss and efficiency. Basic methods for optimum pump system design are listed below:

1. Matching Pump with the load
2. Avoidance of excessive pump head safety factor
3. Pump minimum recirculation for pump protection
4. Pump impeller trim after proportional balance
5. Zone Pumping
6. Primary –Secondary Pumping
7. Parallel-Series Pumping
8. Use of 2-way control valves
9. Increased operating temperature differential
10. Use of true piping pressure drop data
11. Variable Volume Pumping with variable speed motor
12. Selecting an energy efficient motor

There is no one solution, no perfect operating conditions that will yield the best result for any and all applications. Despite the tendency to emphasize initial cost, you will save in the long run by selecting the most efficient pump type and designing efficient system at

the onset. The only “absolute” answer is that, unless the design and selection is backed up with an energy analysis specific to your application, care should be exercised.

MATCHING PUMP WITH LOAD

- Match the pump type to the intended duty
- Don't oversize the pump
- Match the driver type to the intended duty

Pump system selection has been oriented towards considerable safety factor in both flow and head. This is usually done to overcome flow-balancing problems of the system and to ensure adequate flow is available to each of terminal devices. In most of cases the margin is added to compensate for unknowns (inadequate data, fast project schedules etc.). This leads to over sizing of pumps and consequent pumping power wastage.

The pump system power consumption is defined by equation

$$\text{HP} = \text{GPM} \times \text{TDH} \times \text{SG} / (3960 \times \text{Efficiency})$$

In making a choice of pumping systems, engineers put emphasis on the efficiency. While this is OK to have the maximum possible efficiency, one must carefully look at other part of the formula; viz. the pump flow and the head. These two parameters are often neglected. The true energy savings can be found from the correct sizing of parameters (TDH in ft x flow in GPM). For example, a pump efficiency of 70% will correlate to a system efficiency of 35%, if the pump is selected and operated at twice required pump head. If the flow requirements were similarly specified, system-pumping efficiency would decrease to the order of 17.5%.

As a generality, the larger the pump, the higher is the efficiency.

While it is true that the large pumps offer higher efficiency, don't be misguided by this generic statement. It will almost always be true that a smaller pump matched to the system will operate at lowest cost-even though its efficiency as a pump is lower.

AVOID EXCESSIVE HEAD/CAPACITY FACTOR

Avoid allowing for excessive margin of error in capacity and/or total head. It typically will be less expensive to add pumping capacity later if requirements increase.

Small differences in efficiency between pumps are not as important as knowing and adjusting to the service conditions. Energy savings may be as high as 20% if pumps are sized based on reasonable system heads and capacity requirements. Savings result from operating at a more efficient point on the pump curve, and in some cases, this also avoids the need to throttle pump capacity or operate at a higher capacity than necessary.

For instance in HVAC applications, determining the required head may be on rough estimates with high safety margins. It may be that the downstream components, such as coils or control valves, have not been selected, but the pump procurement lead times demand that the pump be ordered immediately. Many designers react to this situation by picking a reasonable amount of head, then adding an arbitrary, large safety factor to cover any possible contingency. Over-head pumps selected in this way are prime candidates for causing operating problems and the system increasingly running out of their curves- increasing flow and drawing more horsepower. If the extra safety factors are included, the result is a pump that provides more flow than required with noise and inefficient operation as the result.

It should be noted that terminal flow rates in excess of design return very little in terms of increased terminal heat transfer, and that the relatively pay-out cost (increased pumping cost) is very high. A 100% safety factor head as applied to a pumping system will cause about 140% required flow. The 40% flow increase over required will only increase HW terminal capacity about 3%, while typical chilled water terminal capacity will only be increased by the order of 7%.

Power requirements for the over-headed pump will be to the order of 2.5 times that otherwise needed; if the actual needed pump power draw were 10 HP, the 100% over headed pump would draw 25 BHP. Wastage of 15 HP or \$ 1750 per year would occur at \$ 0.015 per KWH.

PUMP MINIMUM RECIRCULATION

The pumps should not run for extended time under no flow (shut off head) condition. Centrifugal pumps used in any process application require a minimum flow to be maintained in the system to prevent the pump from overheating, cavitating, and becoming damaged. The minimum flow requirements of a specific pump are stated by

the pump manufacturer that must be preferably maintained using a fail proof recirculation system during low process flow requirements.

There are three principal methods of providing minimum flow protection:

- Using a flow switch to start/stop the pump
- A continuous bypass approach with a control valve/ orifice plate
- An automatic re-circulation control (ARC) valve

STOP – START CONTROL

A minimum-flow control arrangement for pump protection can be achieved using a flow switch to start and stop the pump but shall require an instrument air for the control valve.

In this method switching pumps on or off controls the flow. It is necessary to have a storage capacity in the system e.g. a wet well, an elevated tank or an accumulator type pressure vessel. The storage can provide a steady flow to the system with an intermittent operating pump.

When the pump runs, it does so at the chosen (presumably optimum) duty point and when it is off, there is no energy consumption. If intermittent flow, stop/start operation and the storage facility are acceptable, this is an effective approach to minimize energy consumption.

The stop/start operation causes additional loads on the power transmission components and increased heating in the motor. The frequency of the stop/start cycle should be within the motor design criteria and checked with the pump manufacturer.

It may also be used to benefit from “off peak” energy tariffs by arranging the run times during the low tariff periods.

To minimize energy consumption with stop start control it is better to pump at as low flow rate as the process permits. This minimizes friction losses in the pipe and an appropriately small pump can be installed. For example, pumping at half the flow rate for twice as long can reduce energy consumption to a quarter.

FLOW CONTROL VALVE (BYPASS CONTROL)

In this approach, the pump runs continuously at the maximum process demand duty, with a permanent by-pass line attached to the outlet. When a lower flow is required the surplus liquid is bypassed and returned to the supply source. An alternative configuration

may have a tank supplying a varying process demand, which is kept full by a fixed duty pump running at the peak flow rate. Most of the time the tank overflows and recycles back to the pump suction. This is even less energy efficient than a control valve because there is no reduction in power consumption with reduced process demand.

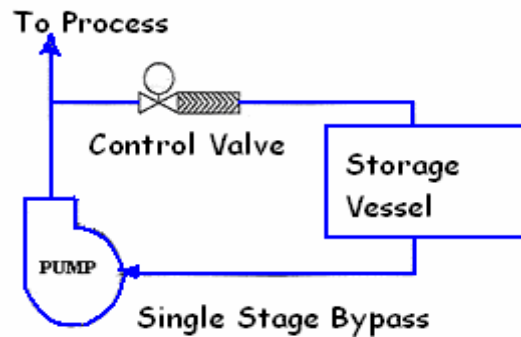

Fig. Minimum Re-circulation with Bypass Control Valve

The small by-pass line sometimes installed to prevent a pump running at zero flow is not a means of flow control, but required for the safe operation of the pump.

Another solution would be to install a hand valve in the re-circulation line, then with some experimentation, set the valve opening for the minimum re-circulation flow desired. Once done, remove the valve handle or lock it in place.

FLOW CONTROL (ORIFICE PLATE)

The simplest solution to the problem is the installation of a minimum-flow-restriction orifice in a re-circulation line from the pump discharge to the suction. The orifice should be sized to pass the minimum flow rate with the pump discharge at maximum or shutoff head. But be careful with orifice solutions. Orifice sizing can be difficult and excessive wear can be a problem depending upon the required pressure drop and available pump head. While this solution is not the most energy efficient and requires that the pump have sufficient excess capacity for the orifice flow plus the process required flow, it does not require any power, controls, or operator attention.

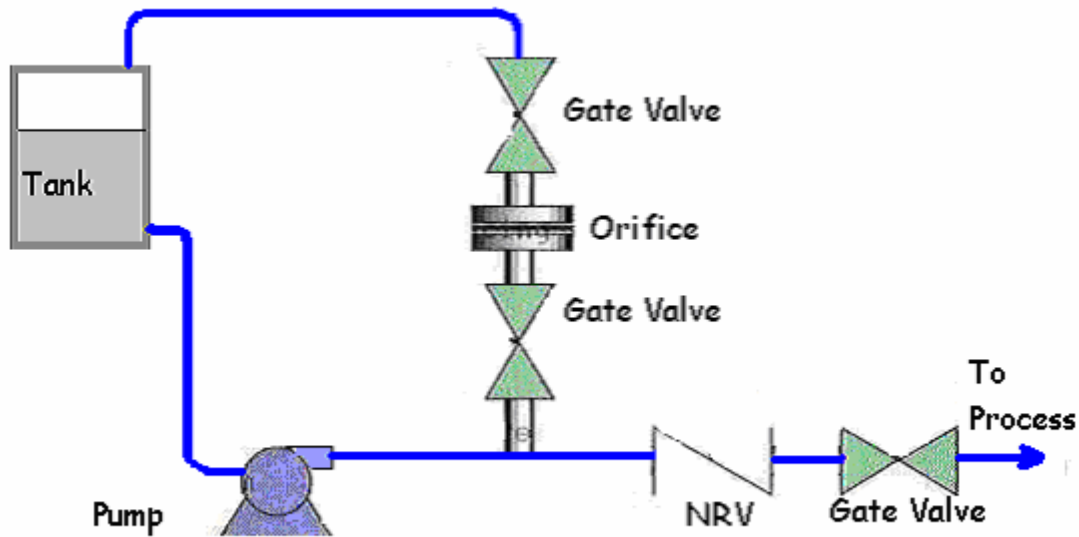

Pump Minimum Re-circulation Control w/Orifice Plate

This system inspection must include a determination of backpressure requirements, an analysis of proper liquid velocities, and an examination to ensure that the appropriate size valve is selected and installed in the right direction. It is the responsibility of the system designer/valve manufacturer to verify that these and other important criteria are considered prior to, during, and following installation so that peak performance of the valve and the system it is protecting is ensured.

Aside from the expense of having to replace the pump and its related equipment so frequently, a system that is unprotected altogether or protected with a continuous bypass device is an extremely inefficient one.

For orifice plate selection for your application refer to the pump handbooks or crane manual.

FLOW CONTROL (ARC VALVE)

The Automatic Re-circulation Control (ARC) Valve eliminates pump damage at the low flow condition by combining the essential elements required to control minimum flow conditions through the pump, including:

- A Flow Sensing Element
- A Bypass Control Valve

- A Cascade Element for Pressure Let-Down
- A Check Valve

The features of Automatic Re-circulation Valves include:

- Modulating Operation
- Fail-Open Design
- Ease of Installation, Vertical or Horizontal, Direct on Pump Outlet
- Suitable for a Wide Range of Fluids
- Wide Range of Temperatures, from -20°F to 400°F

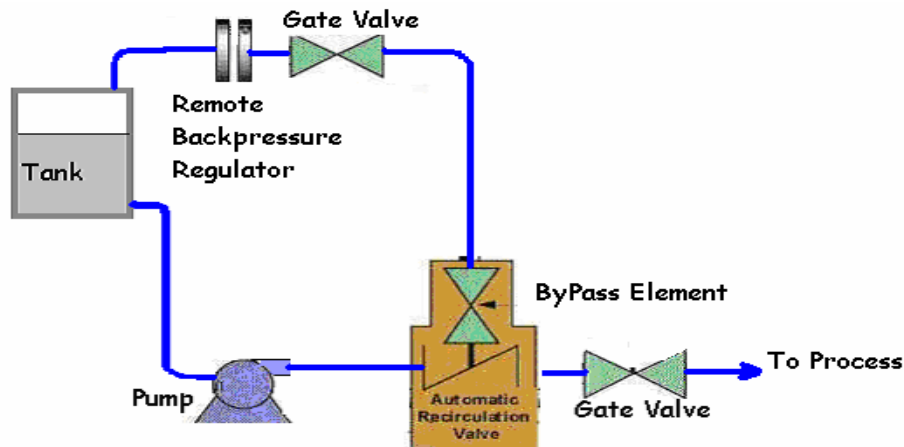

Pump Minimum Recirculation w/ Automatic Recirculation Valve

One Valve - Many Functions

If the flow through the pump falls below a certain level a bypass system opens and fluid will be recirculated providing the required minimum flow through the pump. The main flow positions the check valve at a certain point. The stem of the check valve transmits the motion via a lever to the bypass. The bypass controls the bypass flow in a modulating way and reduces the pressure to bypass outlet level. The full minimum flow is bypassed when the check valve is seated. The bypass is fully closed when the check valve is in its upper position thereby allowing full flow to the system with established minimum flow. The ARC valve provides at least five essential functions:

1. Check Valve Disc prevents reverse flow and positions the bypass for open, closed or modulating flow by detecting the process flow demand.
2. Bypass modulates open when main flow demand falls below the recommended minimum pump flow. Multiple stage pressure reduction prevents flashing / cavitation.
3. Flow straightener eliminates turbulent discharge. Fluid exits valve as a spray rather than a jet. Reduces erosive wear on downstream piping.
4. Integral Pulsation Dampener protects system from water hammer if sudden changes in flow demand occur.
5. Integral Check Valve in bypass prevents reverse flow when bypass is routed into a common return line.

Once the system analysis has been conducted and the valve has been installed, an ARC unit will perform a multitude of important functions that will maintain optimum system efficiency and protect the equipment from premature degradation and failure. There are a number of anomalies that a hydronic system can introduce to an ARC valve that would cause it to prematurely malfunction, and it is important that the valve's manufacturer conducts a complete system analysis to determine the full parameters of the application.

It is well documented that an ARC—when properly installed—is the most practical, cost-effective means of ensuring that minimum flow is met at all times. An ARC valve simplifies the flow control loop and ensures that the pump is never operated below a safe minimum flow rate. An ARC valve, however, is only as effective as the manufacturer that installs and supports it.

VARYING PUMP PERFORMANCE

A pump application might need to cover several duty points, of which the largest flow and/or head will determine the rated duty for the pump. Many pumping systems require a variation of flow or pressure.

To do so, either the system curve or the pump curve must be changed to get a different operating point. The pump is sized to meet the greatest output demand; and therefore shall be operating inefficiently for other duties. It is therefore very important to achieve an energy cost savings by selecting an appropriate control methods, which maximize

power savings during the periods of reduced demand. Three methods are commonly applied:

1. Throttling the pump discharge or putting a control valve near the terminal devices
2. Trimming the impeller
3. Altering the speed of pump say by using variable frequency drive (VFD) motors

The throttling of pump shall alter the system curve while altering the pump speed or diameter shall change the pump curve. The trimming of impeller is a permanent change and should be carefully evaluated, where a pump has to meet the range of duties.

To make an effective evaluation of which control method to use, all of the operating duty points and their associated run time and energy consumption have to be identified, so that the total costs can be calculated and alternative methods compared.

FLOW CONTROL – THROTTLING VALVE

With this control method, the pump runs continuously and a valve in the pump discharge line or near the discharge terminal points is opened or closed to adjust the flow to the required value.

To understand how the flow rate is controlled see figure below. With the valve fully open, the pump operates at “Flow 1”. When the valve is partially closed it introduces an additional friction loss in the system, which is proportional to flow squared. The new system curve cuts the pump curve at “Flow 2”, which is the new operating point. The head difference between the two curves is the pressure drop across the valve.

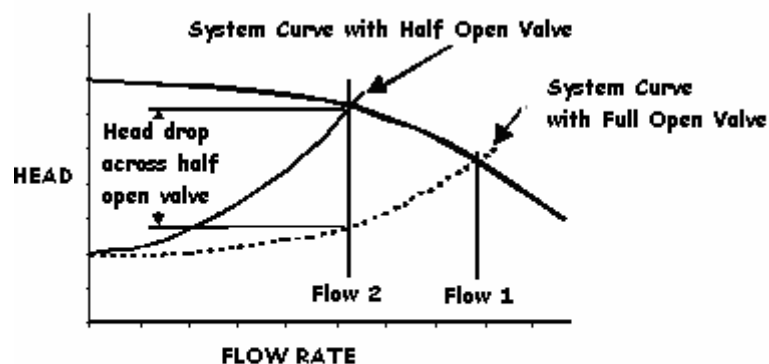

PUMP PERFORMANCE WITH THROTTLING VALVE

It is usual practice with valve control to have the valve 10% shut even at maximum flow. Energy is therefore wasted overcoming the resistance through the valve at all flow conditions.

There is some reduction in pump power absorbed at the lower flow rate, but the flow multiplied by the head drop across the valve, is wasted energy. It should also be noted that, whilst the pump will accommodate changes in its operating point as far as it is able within its performance range, it can be forced to operate high on the curve where its efficiency is low, and where its reliability is impaired.

Maintenance cost of control valves can be high, particularly on corrosive and solids-containing liquids. So the lifetime cost could be unnecessarily high.

EFFECTS OF IMPELLER DIAMETER CHANGE

The 'Affinity Laws' equations relating rotodynamic pump performance parameters of flow, head and power absorbed are:

- Capacity (flow) varies directly as the speed or impeller diameter ($\text{GPM} \propto \text{rpm}$ and D)
- Head varies as the square of speed or impeller diameter ($\text{GPM} \propto \text{rpm}^2$ and D^2)
- BHP varies as the cube of the speed or impeller diameter ($\text{BHP} \propto \text{rpm}^3$ and D^3)

Clearly the power input varies as cube of impeller diameter.

Trimming diameter (D) of an impeller within a fixed casing geometry is a practice for making small permanent adjustments to the performance of a centrifugal pump.

Diameter changes are generally limited to reducing the diameter to about 75% of the maximum, i.e. a head reduction to about 50%. Beyond this, efficiency and NPSH are badly affected.

The illustrated curves are typical of most rotodynamic pump types. Certain high flow, low head pumps have performance curve shapes somewhat different and have a reduced operating region of flows. This requires additional care in matching the pump to the system, when changing speed and diameter.

Magnetically driven pumps, may also need to be treated differently because a change of impeller diameter affects only the hydraulic power. Mechanical power loss in the drive is independent of diameter and so if the speed is unchanged the magnetic losses will not change.

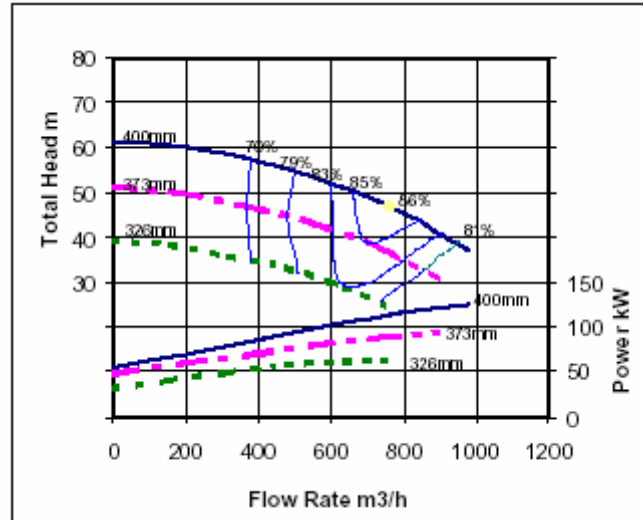

Example of impeller diameter reduction on rotodynamic pump performance

Note: Changing pump impeller diameter effectively changes the duty point in a given system and at low cost, but this can be used only for permanent adjustment to the pump curve.

Typically, a given pump size can accept a range of impeller sizes. A common reason that engineer specifies a larger than necessary pump is to anticipate increases in system capacity. One way to account for future capacity expansion without sacrificing system efficiency is to select a pump that has room to accept larger impellers as the need for system capacity increases. Since an increase in impeller size also requires additional motor power, selecting a motor that is large enough to handle the largest impeller that can fit in the pump can eliminate the need for motor replacement. Care however shall be needed to balance motor sizing with current operating needs so that motor operates efficiently at more than half its rated full load.

In service pumps that are oversized and generating too much pressure may be good candidates for impeller replacement or trimming.

EFFECTS OF SPEED VARIATION

As described above, a centrifugal pump is a dynamic device with the head generated from a rotating impeller. There is therefore a relationship between impeller peripheral velocity and generated head. Peripheral velocity is directly related to shaft rotational

speed, for a fixed impeller diameter and so varying the rotational speed has a direct effect on the performance of the pump.

Remember the 'Affinity Laws':

Capacity varies directly as the speed or impeller diameter (GPM \propto rpm and D)

Head varies as the square of speed or impeller diameter (GPM \propto rpm and D)

BHP varies as the cube of the speed or impeller diameter (BHP \propto rpm³ and D³)

Example: Pump Laws

A cooling water pump is operating at a speed of 1800 rpm. Its flow rate is 400 gpm at a head of 48 ft. The power of the pump is 45 kW. Determine the pump flow rate, head, and power requirements if the pump speed is increased to 3600 rpm.

Solution:

Flow Rate

$$\begin{aligned}V_2 &= V_1 \left(\frac{n_2}{n_1} \right) \\&= (400 \text{ gpm}) \left(\frac{3600 \text{ rpm}}{1800 \text{ rpm}} \right) \\&= 800 \text{ gpm}\end{aligned}$$

Head

$$\begin{aligned}H &= H \left(\frac{n_2}{n_1} \right)^2 \\&= 48 \text{ ft} \left(\frac{3600 \text{ rpm}}{1800 \text{ rpm}} \right)^2 \\&= 192 \text{ ft}\end{aligned}$$

Power

$$\begin{aligned} P_2 &= P_1 \left(\frac{n_2}{n_1} \right)^3 \\ &= 45 \text{ kW} \left(\frac{3600 \text{ rpm}}{1800 \text{ rpm}} \right)^3 \\ &= 360 \text{ kW} \end{aligned}$$

Efficiency is essentially independent

Varying the speed of the pump achieves considerable energy savings because of the laws, which govern the operation of all pumps, in particular that the power of the motor varies by the cube of the speed. This is the critical factor in understanding the electrical energy savings that can be made by using variable-speed pumps. If the pump speed is reduced by 20%, the energy consumption is reduced by 50%.

For example, if you reduce the speed of an 11 kW motor from 2900 rev/min to 2300 rev/min, it will consume only 5.5 kW at the lower speed. Even more dramatically, if you reduce the speed of the pump by 50%, you get a reduction in energy consumption of 87.5%.

To understand how 'speed variation' changes the duty point, the pump and system curves are over-laid.

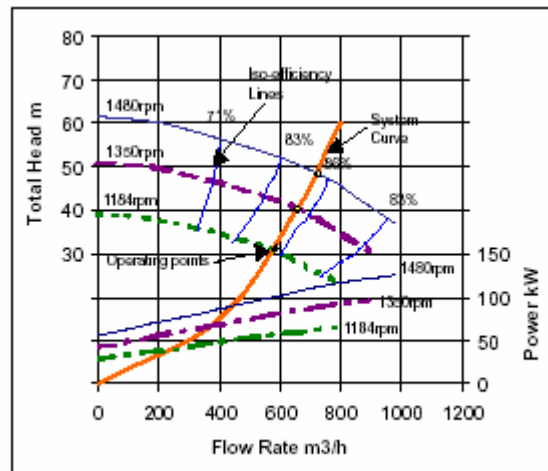

Example of the effect of pump speed change in a system with only friction loss

The figure above shows points of equal efficiency on the curves for the 3 different speeds. The affinity laws give a good approximation of how pump performance curves change with speed. Further the curve assumes the static head is negligible and only friction loss is considered. Reducing speed in the friction loss system moves the intersection point on the system curve along a line of constant efficiency. The operating point of the pump, relative to its best efficiency point, remains constant and the pump continues to operate in its ideal region. The affinity laws are obeyed which means that there is a substantial reduction in power absorbed accompanying the reduction in flow and head, making variable speed the ideal control method for systems with friction loss.

Adopting variable frequency drive (VFD, also called variable speed drive VSD) needs to be carefully evaluated. Note the first two affinity laws, which say that capacity varies directly as speed while head varies as square of speed. This means that the systems requiring high static shall behave differently. In this scenario (high static head, refer figure below), the operating point for the pump moves relative to the lines of constant pump efficiency when the speed is changed. The reduction in flow is no longer proportional to speed. A small turn down in speed could give a big reduction in flow rate and pump efficiency, which could result in the pump operating in a region where it could be damaged if it ran for an extended period of time even at the lower speed.

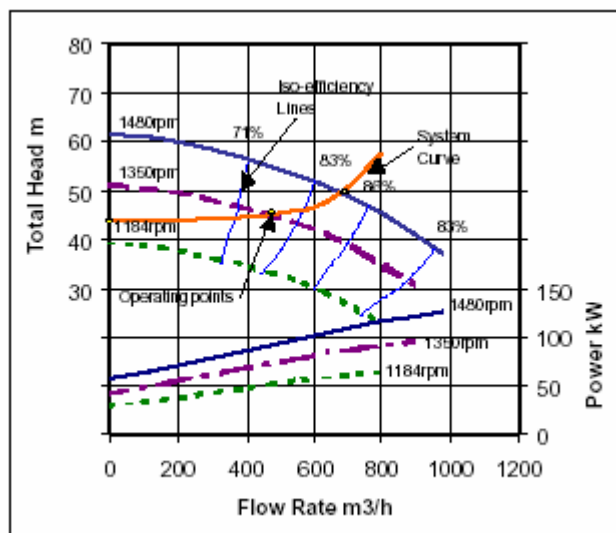

Example of the effect of pump speed change with a system with high static head.

At the lowest speed illustrated, (1184 rpm), the pump does not generate sufficient head to pump any liquid into the system, i.e. pump efficiency and flow rate are zero and with energy still being input to the liquid, the pump becomes a water heater and damaging temperatures can quickly be reached.

The drop in pump efficiency during speed reduction in a system with static head reduces the economic benefits of variable speed control. There may still be overall benefits but economics should be examined on a case -by -case basis.

The savings in the energy costs of a pump system have a tremendous impact on the overall life cycle cost profile, where typically the capital cost is only 2 to 3%, compared with an energy cost of more than 95%. This consideration needs to become a key factor in the capital-purchase decision-making process for building consultants and operators.

For example, the capital cost of a 4 kW fixed-speed pump will be \$1400; maintenance over 20 years would be about \$2900, but the energy cost over the same period (based on current prices) would be \$55000. That gives a total lifetime cost of about \$59300. The picture is the same with a larger fixed speed pump — say 11 kW — which would have a total cost over 20 years exceeding \$150000 — split \$2500 for the capital cost, \$3500 on maintenance and the rest (some \$144000) on energy.

Switching to a variable-speed pump system could save halve these energy costs — considerably reducing the impact on the business.

COMPARISON – THROTTLING V/s SPEED CONTROL

The most important difference of flow control by throttling compared to VFD is that the throttling alters the system curve while the VFD alters the pump curve. It is relevant to note that flow control by speed regulation is always more efficient than by control valve, which can be seen in the discussion below.

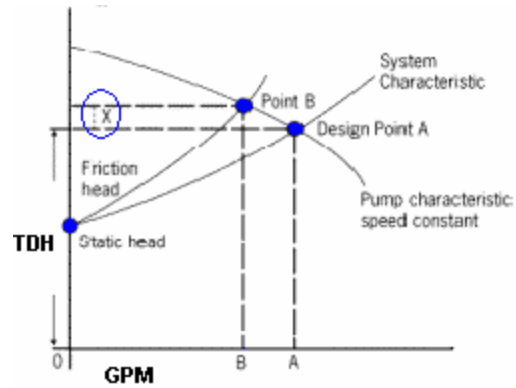

To understand the impact of throttling on the system, refer the figure above. With the valve fully open, the pump operates at design point A. When the reduced flow is required, the discharge valve is throttled, which changes the system curve to operating point B. In this case, the reduced throughput of the system “B” GPM is achieved with a net TDH of X ft. The throttling introduces an additional friction loss in the system, which is proportional to flow squared. The head difference between the two curves is the pressure drop across the valve.

In figure below, the alternative is demonstrated, reducing the speed of the pump. In this case, the reduced throughput of the system “B” GPM is achieved with a net reduction in TDH of Y ft. Therefore, by using variable speed instead of throttling, the saving is the difference in THD of (X+Y) ft.

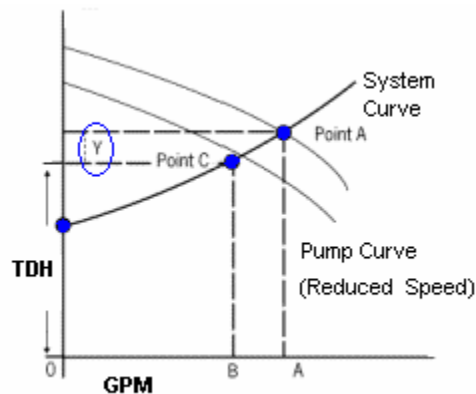

The combined set of typical pump characteristics is shown in Figure below, illustrating the effect of speed variation verses throttling on both pump efficiency and absorbed power. The most notable points illustrated are that throttling the system does not reduce

throughput at the cost of increasing absorbed power as popularly believed; the power absorbed does reduce as the throttle is closed.

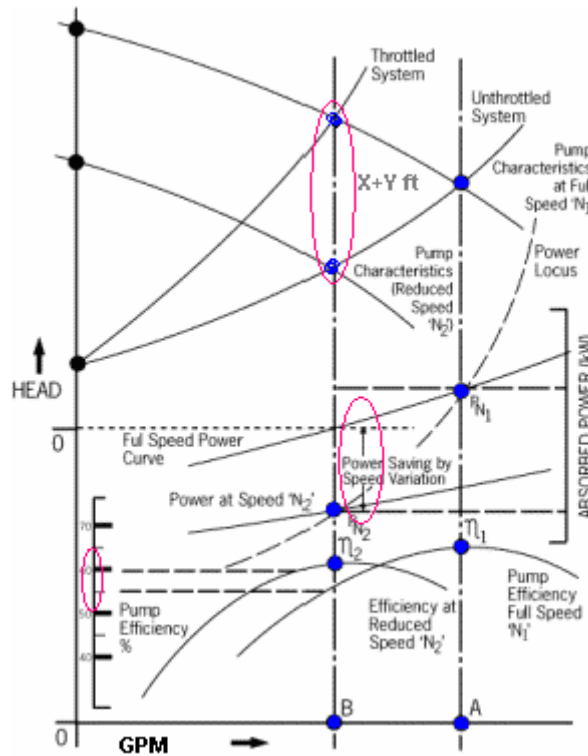

The absorbed power locus which passes through points PN1 and PN2, indicates that even at zero flow, some power is still absorbed, and this constant component of absorbed power is necessary to overcome the static head, which is constant in many pump systems. The power locus has a 'cube law' characteristic for speed/flow against power, and this enables a calculation of the energy savings.

In the figure, the efficiency characteristics are also shown. The pump is selected to operate at peak efficiency, but throttling the system defeats that objective, and results in the pump operating at efficiency well below its peak value. From the efficiency curves, it is clear that from approximately 70% to 100% throughput, varying the speed loses little efficiency.

Consequently, it is clear that significant energy, and therefore cost, savings are available by using a variable speed system employing inverter drives instead of throttling the pump.

Flow control by speed regulation of pumps, is one of today's best methods of varying the output and in addition to energy savings there could be other benefits of lower speed.

The hydraulic forces on the impeller, created by the pressure profile inside the pump casing, reduce approximately with the square of speed. These forces are carried by the pump bearings and so reducing speed increases bearing life. In addition, vibration and noise are reduced and seal life is increased providing the duty point remains within the allowable operating range.

The corollary to this is that small increases in the speed of a pump significantly increase power absorbed, shaft stress and bearing loads. It should be remembered that the pump and motor must be sized for the maximum speed at which the pump set will operate. At higher speed the noise and vibration from both pump and motor will increase, although for small increases the change will be small. If the liquid contains abrasive particles, increasing speed will give a corresponding increase in surface wear in the pump and pipe work.

However speed change can be used over a wider range without seriously reducing efficiency. For example reducing the speed by 50% typically results in a reduction of efficiency by 1 or 2 percentage points. The reason for the small loss of efficiency with the lower speed is that mechanical losses in seals and bearings, which generally represent <5% of total power, are proportional to speed, rather than speed cubed.

In summary variable speed drive offers

1. Energy cost savings
2. Reliability improvements
3. Simplified pipe systems (elimination of control valves & by-pass lines)
4. Soft starts and stops
5. Reduced maintenance

All amounting to lower life cycle costs.

SELECTING VARIABLE SPEED DRIVE

Sizing and Selection

When the pump maximum duty is known, the peak power and speed for the drive will become clear. It is essential to commence the sizing exercise with the hydraulic system, and to work systematically to select the pump, motor and drive.

It would be normal to add a tolerance equal to the potential fall off in efficiency over the maintenance life of the system. It is recommended when selecting a Rotodynamic pump that the maximum flow rate is to right hand side of the best efficiency point.

VFD SAVINGS

Pump Speed (%)	Input Power (%)
100	100
90	73
80	51
70	34
60	22
50	13
40	6
30	3

Control

A pump with variable speed capability will need to be controlled to unlock all the benefits available from variable speed operation.

The effect of varying speed with a centrifugal pump is to vary both head and flow.

Variation of speed with a positive displacement pump will vary only the flow rate.

The table below shows the most commonly applied control-sensing configuration to vary the performance of pump through variable speed drive.

<u>Process</u>	<u>Controlled Parameter</u>	<u>External influence</u>
Heating system	Temperature	Ambient
Tank filling	Level	Outflow
Pipeline	Flow	Level
Distribution	Pressure	Draw-off

Control by fixing pressure

The most common form of control is by use of a discharge pressure sensor, which sends a signal to the VFD, which in turn varies the speed allowing the pump to increase or decrease the flow required by the system.

This form of control is common in water supply schemes where a constant pressure is required but water is required at different flows dependant on the number of users at any given time. Capacity changes at constant pressure are also common on centralized cooling and distribution systems and in irrigation where a varying number of spray heads or irrigation sections are involved.

Cooling and Heating System Control

In heating and cooling systems there is a requirement for flow to vary based on temperature?

In this instance the VFD is controlled both by a temperature sensor and differential pressure. The temperature controller actuates the control valve that regulates chilled water or hot water supply to the heat exchanger and the pressure changes in a system as a result of opening and closing of control valve provides control signal to the VFD. Sometime in process applications the temperature controller directly controls the VFD to allow flow of hot or cold liquid in the system to increase or decrease based on the actual temperature required by the process.

This is similar in operation to pressure control, where the flow is also the variable entity, but a constant temperature requirement from a temperature sensor replaces that from a pressure sensor.

Control by fixing flow but varying pressure

In irrigation and water supply systems constant flow is often required, even though the water levels both upstream and downstream of the pumping station vary.

Also many cooling, chiller, spraying and washing applications require a specific volume of water to be supplied even if the suction and delivery conditions vary. Typically suction conditions vary when the height of a suction reservoir or tank drops and delivery pressure can change if filters blind or if system resistance increases occur through blockages etc.

The VFD system is usually the optimum choice to keep constant the flow rate in the system using a control signal from a flow meter, which can be, installed in the suction, but more commonly the discharge line.

Implementation

In many cases there will be an external control system, such as a PLC or PC, which will provide the start/stop control and an analogue speed reference to the drive or will pass this information to the drive by a serial communications link. In other cases the drive may have adequate on board intelligence.

All modern drive systems rely on microprocessor control, and this allows the manufacturer to integrate the basic signal processing functions into the drive.

As every case has its own specific requirements, it is important that the control requirements are understood in order to achieve the optimum system performance.

INCREASING TEMPERATURE RANGE (Chiller/Heat Exchanger Systems)

Long standing conventional practice of designing the chiller systems on 'ARI' conditions (54/44 °F chilled water, 85/95 °F condenser water) works very well for many applications.

The 10°F rise for chilled water (1 GPM per 5000 Btu/hr) and 20°F drop for heating (1 GPM per 10000 Btu/hr) has been standard norm over years and was primarily to establish a high order safety factor against flow balance problems-but is wasteful because the system is generally over pumped when compared with other design of higher delta T possibilities.

To evaluate this, let's look to the following formula:

$$\text{Load (tons)} = \text{Flow (GPM)} \times \text{Temperature range (°F)} / 24$$

Or

$$\text{Flow (GPM)} = \text{Load (tons)} \times 24 / \text{Temperature Range (°F)}$$

As the chilled water temperature range is increased, the flow rate is decreased for the same capacity. Smaller flow means smaller pipes, pumps, insulation (area not R value), etc. This equates to capital savings. Notice that the chilled water supply temperature is not part of the equation. It has nothing to do with these savings!

To evaluate the operating cost, let's consider the following formula:

$$\text{Pump power (hp)} = [\text{Flow (GPM)} \times \text{Head (ft)}] / [3960 \times \text{Pump efficiency}]$$

As the chilled water flow is decreased, the pump work is also decreased, assuming constant head. This equates to operating savings.

The pump head will remain approximately constant because the pipe sizes will be decreased. ASHRAE recommends that piping design be based on a 4-foot pressure drop per 100 feet of pipe. Maintaining this requirement will let the designer downsize piping as the flow decreases.

Many system design today use increased operating temperature difference to reduce flow rate 15°F shall allow 1 GPM per 7500 Btu/hr and 40 deg delta drop for heating shall allow 1 GPM per 20000 Btu/hr.

A word of caution:

The discussion above is a very strong argument for increasing the chilled water temperature range. But note that the above considerations only focus on the pumps and piping. Focusing on life cycle cost will affect this scenario. Designers must consider the entire HVAC system and evaluate the impact of changing the chilled water temperature range on the chiller energy consumption!

It is necessary to strike a balance between capital cost and operating cost. It is here that changing the chilled water temperature range becomes an issue. Note: we have seen in the formula that chilled water supply temperature has nothing to do with the savings.

It is important to consider the entire system as a whole to visualize the operating costs.

Starting with the Chiller

The purpose of a chiller is to collect heat from the chilled water loop and reject it in the condenser water loop. This process takes work, so a compressor is required.

The work done or power absorbed by the compressor is the enthalpy difference at evaporator and the condenser.

For this discussion, temperatures will be used as the measurement. Increasing the lift will increase the compressor work and lower the chiller efficiency. This is physics and it occurs regardless of compressor types, refrigerant type or the manufacturer. The specifics will define the size of the efficiency penalty, but there will always be a penalty.

The operating costs are low if the chilled water temperature range is increased 'provided' the supply water temperature is held constant. If the supply water temperature lowered, then the refrigerant boiling temperature will have to be lowered. This will increase the compressor lift and lower the chiller performance.

The Effect on Cooling Coils

The cooling coils collect heat from the air and transfer it into the chilled water, raising the water temperature. A cooling coil is a heat exchanger as well that will transfer energy proportional to its LMTD. In this case, increasing the chilled water range while maintaining the same supply water temperature will hurt the coil performance. The designer has two choices, either increase the coil area to offset the decrease in LMTD, or lower the chilled water supply temperature to maintain the LMTD. To maintain the supply air conditions, the coil area is increased through rows and fins, which increases the air pressure drop.

Also it is important to note that decrease system flow need per BTU transfer establishes more stringent flow balance requirements.

What about Condenser Water Temperature Ranges?

Increasing the condenser water temperature range will decrease the pipe and pump size and the operating cost of the condenser pump. It will also require the condensing temperature to increase, which will increase the compressor lift and decrease the compressor performance. The higher "average" condenser water temperature (or increased LMTD) will improve the cooling tower performance, allowing for a smaller cooling tower.

Putting It All Together

Increasing the chilled water temperature range will reduce pipes, pumps, insulation, etc. It will also save on pump operating costs because the pump motor will be smaller. Lowering the chilled water supply temperature will result in some combination of increased chiller cost and reduced chiller performance. If the chilled water supply

temperature is reduced, consider over sizing the cooling tower to reduce the condenser water temperature and minimize the affect on the chiller.

Increasing the coil area (adding rows and fins) will increase the coil cost and increase air pressure drop. Increasing the condenser water temperature range will reduce the condenser pump, pipe and cooling tower sizes, saving capital costs. On the other hand, it will result in some combination of increased chiller cost and reduced chiller performance. Always optimize the (expensive) chiller over the (inexpensive) cooling tower.

The best answer is the combination of components that provides the best life cycle performance. This can only be found by performing an annual energy analysis, followed by a life cycle analysis. There is no substitute for annual energy analysis.

There are little capital savings to go beyond the 13°F temperature range. Increasing the chilled water temperature range is a good way to reduce the capital and pump operating cost, particularly if the pump head is large or the piping runs long.

Consider an Example:

Assume a primary circuit is connected to a boiler having an output of 250,000 Btu/hr.

The intended temperature drop of the loop under design load conditions is 15°F. What is the necessary primary loop flow rate? How does the flow rate requirement change if the primary loop is operated with a 30 degrees F temperature drop?

The flow rate necessary to deliver the full output of the heat source at a specific temperature drop can be found using equation below:

$$f_p = \frac{Q_{HS}}{8.01 \times D \times c \times (\Delta T)}$$

Where:

- f_p = required flow rate in the primary circuit (gpm)
- Q_{HS} = heat output rate of heat source (Btu/hr)
- ΔT = intended temperature drop of the primary circuit (degrees F)
- D = the fluid's density at the average system temperature (lb/ft³)
- c = the fluid's specific heat at the average system temperature (Btu/lb/degrees F)

- 8.01 = a constant

In small to medium size hydronic systems, the product of (8.01 x D x c) can be taken as 490 for water, 479 for 30% glycol, and 450 for 50% glycol.

Now run the numbers in the formula above.

$$f_p = \frac{Q_s}{490(\Delta T)} = \frac{250,000}{490(15)} = 34 \text{ gpm}$$

$$f_p = \frac{Q_s}{490(\Delta T)} = \frac{250,000}{490(30)} = 17 \text{ gpm}$$

The required flow rate in the primary loop is 34 GPM and 17 GPM when the temperature drop is 15°F and 30°F respectively.

It's apparent that doubling the intended temperature for the primary loop cuts the required flow rate to half. Not only does this reduce the capital cost of reduced pipe size, pumps, it also reduces size of circulator. The smaller circulator will likely operate on lower wattage, and thus reduce the operating cost of the system.

USE OF APPROPRIATE PRESSURE DROP DATA

System head loss determination should be made using piping head loss values most suitable to the closed loop heating/cooling system; ASHARE, Hydraulic institute or its equivalent etc.

The chilled water system is essentially a closed water system and the condenser water-cooling system is an open system. By open system it implies that the water is exposed to atmosphere at the cooling tower nozzles while the closed system the water keeps on circulating in a closed loop without exposure to environment. There is negligible water loss in the closed system while the open system has losses associated with the cooling tower evaporation, drift and windage.

Tables stated to William & Hazen "C" factor of 100 should not be used on the closed water system. Engineers concerned with open city water distribution type systems apparently intend these tables for use. William & Hazen tables with C of 100 establishes head loss to the order of twice the true value and the consequently over headed pump selection increase power consumption.

PARALLEL PUMPING

A pump application might need to cover several duty points, of which the largest flow and/or head will determine the rated duty for the pump. The pump user must carefully consider the duration of operation at the individual duty points to properly select the number of pumps in the installation and to select output control.

An energy efficient method of flow control, particularly for systems where static head is a high proportion of the total, is to install two or more pumps to operate in parallel.

Variation of flow rate is achieved by switching on and off additional pumps to meet demand. The combined pump curve is obtained by adding the flow rates at a specific head. The head/flow rate curves for two and three pumps are shown in Figure below.

The system curve is usually not affected by the number of pumps that are running. For a system with a combination of static and friction head loss, it can be seen, in Figure, that the operating point of the pumps on their performance curves moves to a higher head and hence lower flow rate per pump, as more pumps are started. It is also apparent that the flow rate with two pumps running is not double that of a single pump. If the system head were only static, then flow rate would be proportional to the number of pumps operating.

It is possible to run pumps of different sizes in parallel providing their closed valve heads are similar. By arranging different combinations of pumps running together, a larger number of different flow rates can be provided into the system.

Care must be taken when running pumps in parallel to ensure that the operating point of the pump is controlled within the region deemed as acceptable by the manufacturer. It can be seen from figure that if 1 or 2 pumps are stopped then the remaining pump(s) shall operate well out along the curve where NPSHR is higher and vibration level increased, giving an increased risk of operating problems.

Many software packages are currently available which make it easier to determine friction losses and generate system curves. Most pump manufacturers can recommend software suitable for the intended duty. Different programs may use different methods of predicting friction losses and may give slightly different results. Very often such software is also linked to pump-selection software from that particular manufacturer.

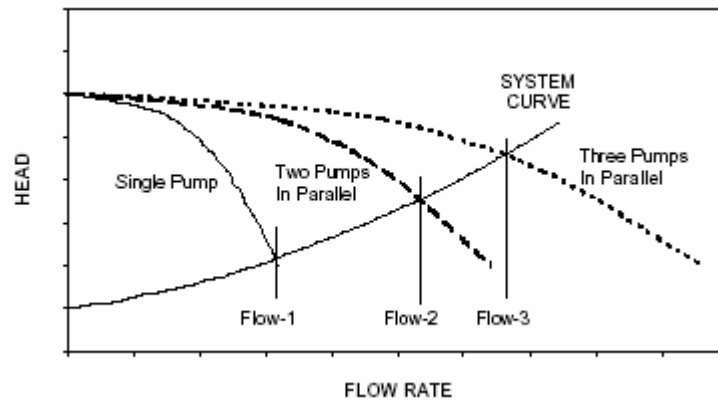

Typical Head-flow curves for pumps in parallel, with system curve illustrated.

Identical Pumps

Operating two identical pumps in parallel the assumption is made that the flow will double. This however is not the case. In order to calculate the additional flow realized by running two identical pumps in parallel the following calculations must be made.

When two pumps are better than one

Parallel pumping involves installing two circulating pumps in a piping system in parallel with each other. When selected properly, each circulator will pump half of the total required flow rate at the design head loss. This means that each pump is capable of pumping half of the gallons per minute needed at the total designed pressure drop for an application.

For example, if you need to pump 750 GPM @ 40ft head you have several choices:

1. You can select one pump that is capable of meeting the design conditions
2. You can also pick one additional pump as 100% stand-by, or
3. You can pick two smaller pumps in parallel to meet the condition.

If you decide to use two smaller pumps in parallel, you could choose two pumps capable of pumping 375 GPM at 40'. When they are both piped into the system and turned on, they will provide a total flow rate of 750GPM at 40' of head.

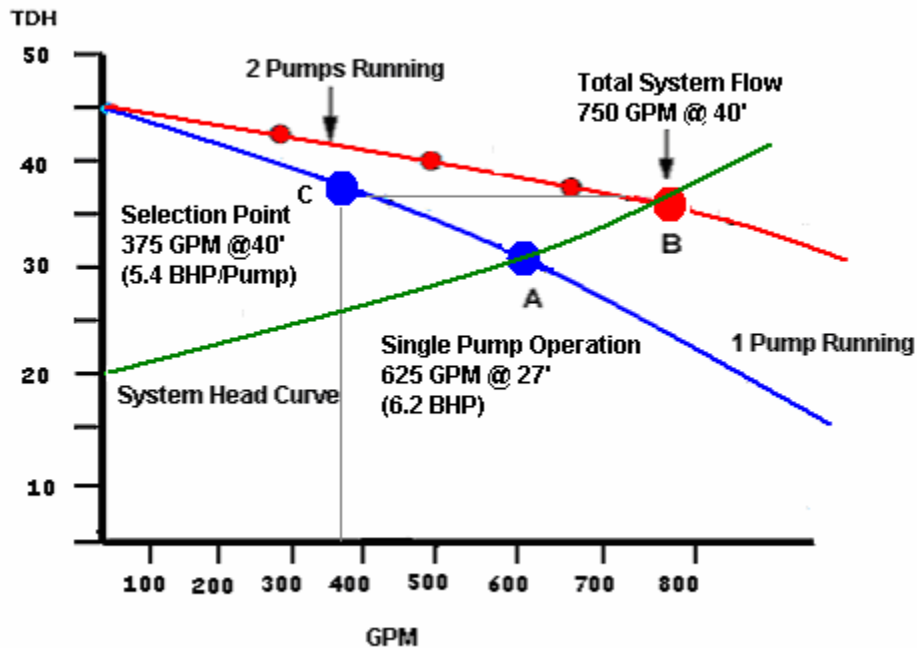

If you look at the pump curve above, you'll see that when one pump is in operation it crosses system curve at about 625 gpm at 27' of head. (Note that when one pump operates, it moves more gpm than when both are working)! In this example, the flow is ~75% of design, which can handle most loads.

Look at the pump curve and system head curve at different scenarios:

Each pump shall produce; operating point C – 350 gpm @ 40 ft head

With 2 pumps running; operating point B - 750 gpm @ 40 ft head; total power draw 10.8 BHP

With single pump running; Operating point A – 625 gpm @ 27ft head; power draw increases to 6.2 BHP

What happens when one of the pumps shuts off?

One major benefit of parallel pumping is the high degree of standby capacity provided by single pump operation. When one pump is out of operation, the other pump continues to pump water through the system. But the flow rate isn't cut in half just because only one pump is operating. Remember, the pump has to operate at the intersection of its pump curve with the already determined system curve. In our design example a standby flow of 625 gpm shall be available should one pump fail. Also note that the single pump

power draw increases to 6.2 BHP from 5.4 BHP when both pumps operate. Pump motor size must be stated for single pump operation.

During lean periods such as in air-conditioning applications where 90% of the time the plant is operated at low loads, switching to single pump operation shall save ~4.5 BHP per hour while maintaining more than adequate terminal flow rates and system reliability.

Ideally the pumps should be of equal size and designed for parallel operation. Pumps with differing flow and head characteristics do not work well together in parallel.

SERIES PUMPING

Pumps in series double the head at the same flow condition point. One pump discharge is piped into the suction of the second pump producing twice the head capability of each pump separately. The second pump however must be capable of operating at the higher suction pressure, which is produced by pump number one.

This mode of operation is a very cost effective way of overcoming high discharge heads when the flow requirement remains the same. Series pumping is most effective when the system head pressure curve is steep. When the head pressure is not a constraint, parallel pumping is preferred.

Centrifugal pumps are used in series to overcome a larger system head loss than one pump can compensate for individually. As illustrated in Figure, two identical centrifugal pumps operating at the same speed with the same volumetric flow rate contribute the same pump head.

Since the inlet to the second pump is the outlet of the first pump, the head produced by both pumps is the sum of the individual heads.

The volumetric flow rate from the inlet of the first pump to the outlet of the second remains the same.

Consider for example an application with a relative high head 80' @ 250 gpm that would seem adaptable to series application. Given that equally sized pumps are to be used, each pump would provide one half total head at the required system flow rate; i.e. each pump would be selected for 250 gpm @ 40'.

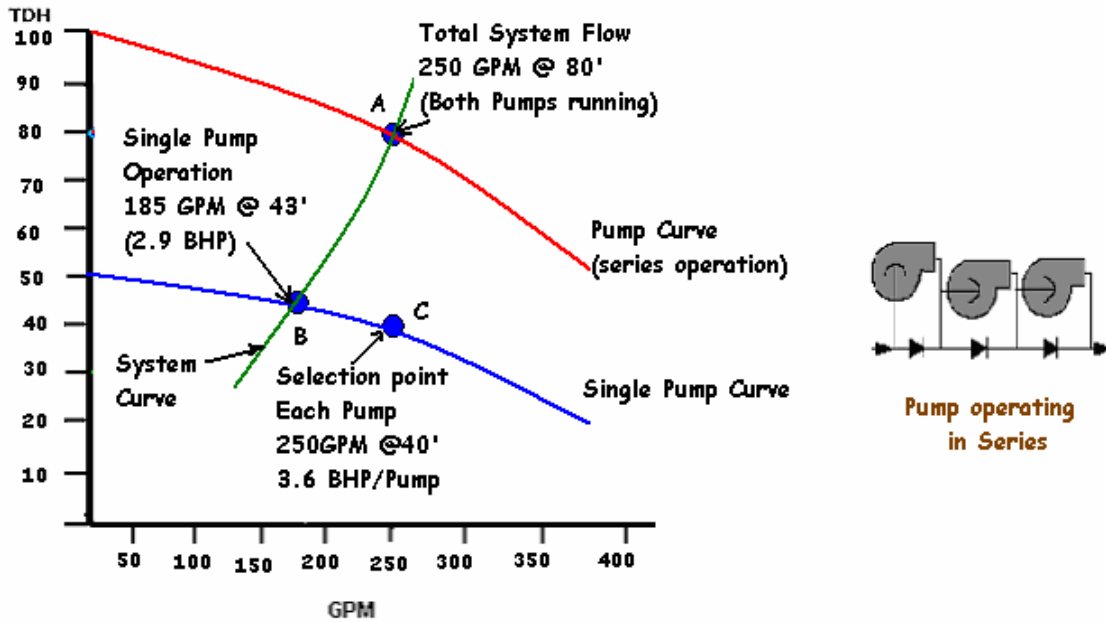

When both the pumps operate, design flow of 250 gpm @ 80' will be available. Adequate standby flow to the order of 185 gpm will be available should one pump become operational. During the lean period 185gpm will be more than adequate and could save 2.9 BHP per hour or operation.

Remember:

- Pumps piped in series must have the same capacity (impeller width and speed).
- Pumps piped in parallel must have the same head (impeller diameter and speed).

ZONE PUMPING

It should be remembered that the sharply set balance valves consume power. Power loss through a sharply set throttle valve is set by the same relationship as power input by a pump.

Power consumption, BHP = $\text{GPM} \times \text{Ft head loss} / 3960 \times \text{Pump Efficiency}$

A great deal of power waste can be avoided by zone pumping: high flow low head circuits and low flow high head circuits should be individually pumped. This avoids the power waste caused by a single pump whose head selection base is to a high head low flow circuit and which needs excessive throttle on its high flow low head circuit.

Consider an example below:

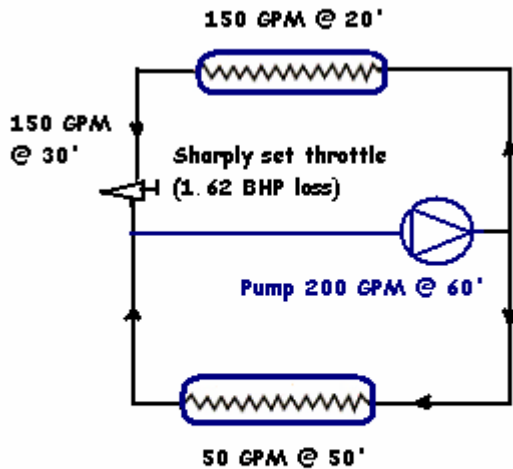

**Single pump @ 4.35 BHP
@ 70% Pump Efficiency**

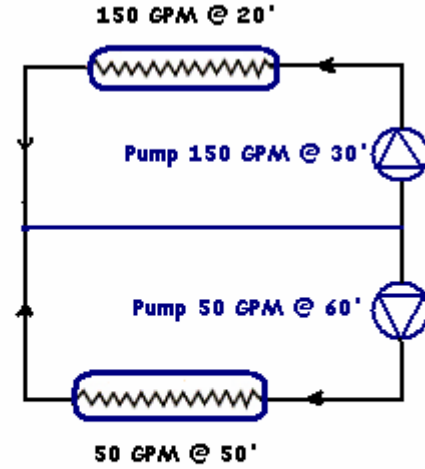

**Two Zone Pumps (total 2.7 BHP
@ 70% Pump Efficiency)**

The scheme left indicate a single pump serving two heat exchangers; one with 150gpm flow @ 20' (high flow and low head) and second heat exchanger demanding 50gpm @ 50' (low flow and high head). Pump is selected for 200gpm @ 60' (accounting for 10' loss in the suction line). The circuit is balanced through a use of plug valve which is throttled to allow 150gpm through the top heat exchanger. The total energy consumed in operation is 4.35 BHP @ 70% pump efficiency. A loss of 1.62 BHP occurs at a throttled valve.

Zone pumping provides opportunity for high order energy savings and tends to simplify the overall balance problem when properly applied. The scheme shown on the right uses two individual pumps for the two circuits and eliminates the need for the balancing through plug valve. Head loss common to all zone pumps (10' at the suction) must be considered when zone pumps are used because variation in this head loss will cause zone pump flow changes. Head loss between supply and return headers must be maintained at a constant value. Clearly this scheme is more efficient, draws less power, eliminate balancing problems and provide redundancy should one circuit fails. The first cost on two pumps shall be little high.

PRIMARY-SECONDARY PUMPING

Primary-secondary pumping is simple in theory as well as operation. It is based on a simple fact: when two circuits are interconnected, flow in one will not cause flow in the other if the pressure drop in the piping common to both is eliminated.

There is really nothing very complicated about primary/secondary pumping systems. Basic principles are involved and an understanding of these principles is all that is necessary to understand primary/secondary-pumping systems.

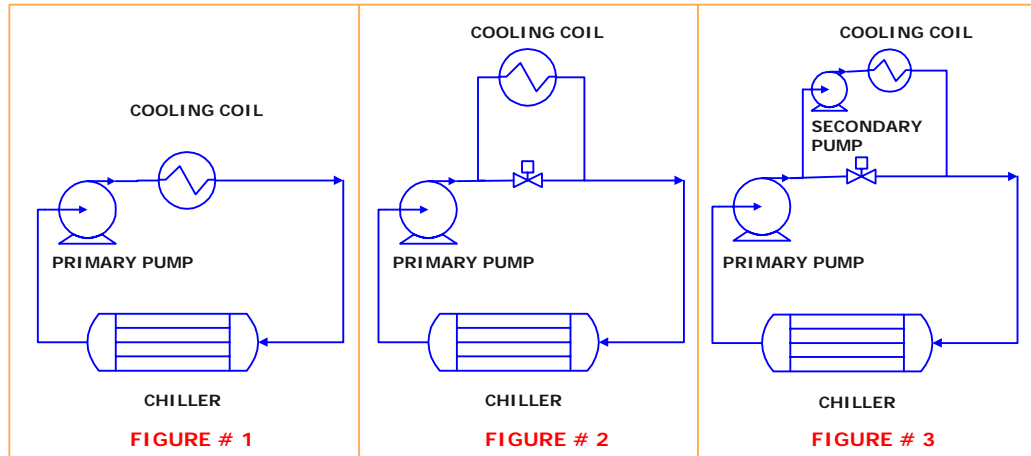

Figure # 1: What we see is a simple loop where primary circulator provides water flow around the loop. The water just goes around and around.

Figure # 2: Here we have added a second loop by using regular tees and a valve between the tees. Depending on whether the valve is open, closed, or somewhere in between, water may or may not flow through the secondary loop because the ΔP is greater in the loop than the ΔP between the tees. Throttling the valve will increase the ΔP between the tees and will determine how much water will flow in the secondary loop. You could also get the same effect by using a smaller sized pipe between the tees, because a smaller pipe will produce a greater ΔP at the same flow rate than a larger pipe. None of those methods gives any “control” of the loop. You can’t conveniently start, stop, or change the flow through the loop.

Figure # 3: Here we have added a pump to the secondary loop. The primary pump runs continuously and when the secondary pump is off, no water will flow through its loop because the ΔP of the secondary loop is greater than the ΔP between the tees. When the secondary pump is on, water will flow in the loop because the pump changes the ΔP relationship.

Let’s examine the system more closely...

What's very important is what the ΔP is between the tees (between nodes A & B). That piece of pipe is common to both loops, so its ΔP must be very low! The piece of pipe should be the size of the main and 6 to 12 inches long. We want the pumps to work together. When we have a system with two pumps, one more powerful than the other, if we are not careful, we can create problems.

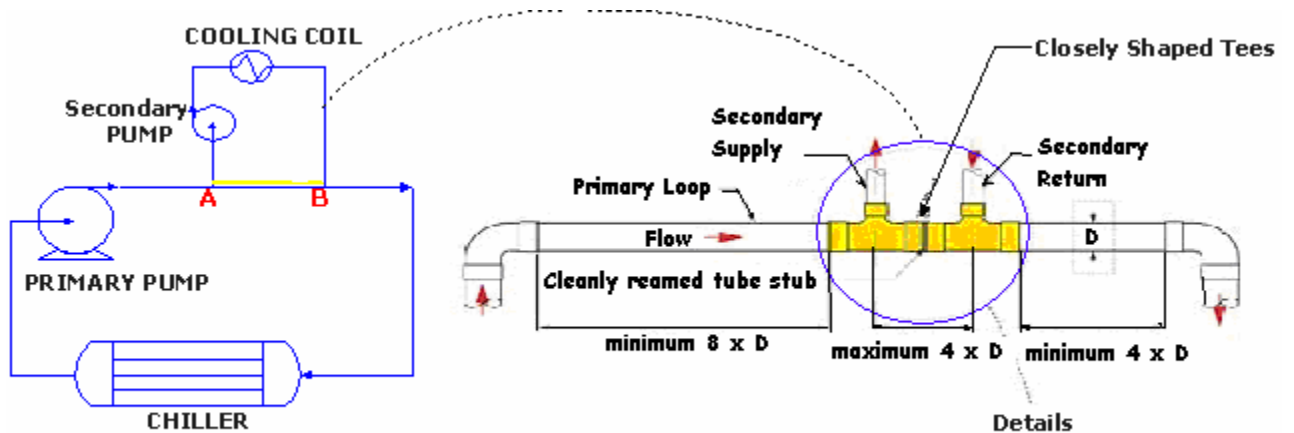
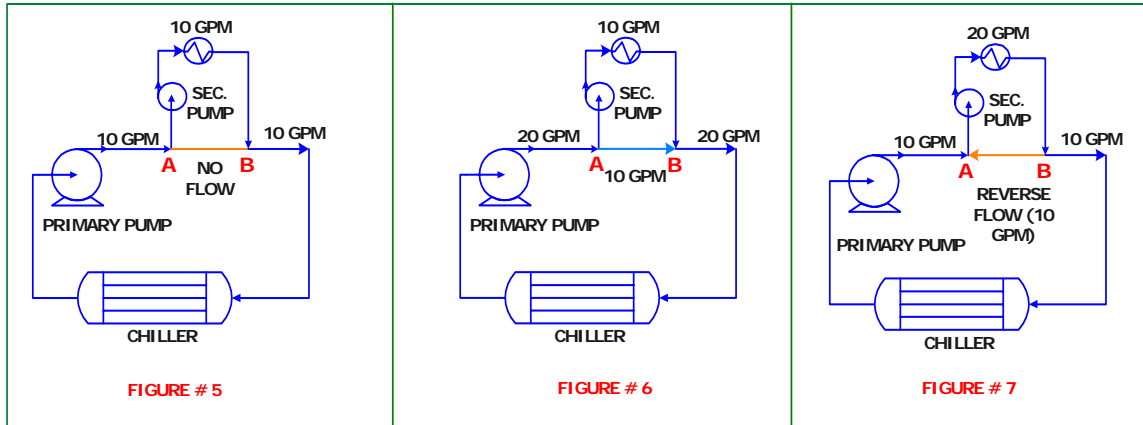

FIGURE # 4

Look at Figure 4 above. The pressure produced by the high head primary pump at "A" and "B" is virtually the same. (Remember, "A" to "B" is now 6 to 12 inches long.) The high head pump P won't circulate water through the secondary loop, because the common piping, "A" to "B," is the path of least resistance. When the secondary pump comes on, it can pump away from the common piping, around its loop that includes "A" to "B," and back to its own suction. The high head pump can't shut down the secondary pump. They operate as if they are two independent systems.

Depending on the flow rates of the primary and secondary pumps, water can move forward, backwards, or not at all!



Figure# 5: If both pumps are sized for a flow rate of 10 GPM, when the primary pump is on and the secondary pump is off, 10 GPM will flow across “A” to “B.” When the secondary pump is on, there will be no flow across “A” to “B,” the common piping. All the water will flow through the secondary loop.

Figure # 6: Let’s change the primary pump to one that can pump 20 GPM. Now, when both pumps are on, the flow through the common piping, “A” to “B,” will be 10 GPM. Remember a simple rule. “What enters a tee must leave a tee,” or “what leaves a tee must enter a tee.”

Figure # 7: Let’s switch the pumps. The primary pump is now the 10 GPM pump and secondary pump is 20 GPM. When the primary pump is on and the secondary is off, 10 GPM will flow across “A” to “B,” the common piping. But now the secondary pump, the 20 GPM pump, comes on. 20 GPM flows in the secondary loop! How can this be? 10 GPM reverse flow will occur in the common piping, “B” to “A.” Remember, what leaves a tee must enter a tee. If we draw 20 GPM out of the branch of the tee at “A,” we must have 20 GPM enter the tee from one or both sides. 10 GPM is being supplied in one side of the tee from the primary pump; so 10 GPM must come from the other side of the tee. The secondary pump has to draw that 10 GPM from its own flow, creating backwards flow across the common piping when both pumps are on. This could be useful where a two-temperature system is needed. Return and supply water can be blended to have a two-temperature system without using a three-way valve.

Summarizing the above discussion... Remember these rules of thumb

#1 The Common Pipe

The key to all primary-secondary applications is the use of a common pipe, which interconnects the primary and secondary circuits. The length of this pipe should be kept

very short in order to keep the pressure drop very low, and the supply and return tees to the secondary circuit should be a maximum of four pipe diameters apart. By keeping the pressure drop very low, water that is flowing in the primary loop will not flow into the secondary circuit until its circulator turns on.

#2 The Secondary Circulator

A separate circulator is installed in the secondary circuit to establish flow. This circulator is sized to move the flow rate and to overcome the pressure drop of its circuit only. The circulator should be located so it is pumping away from the "common piping" and discharging into the secondary circuit. This causes an increase in pressure in the secondary circuit rather than a reduction in pressure, which would occur if the pump were located on the return pumping towards the common pipe.

#3 The Law of the Tee

This rule determines the flow rate and direction of flow that occurs in common piping. It is based on the relationship of the primary and secondary flow rates, and there are three possibilities to evaluate:

- 1) Primary flow more than secondary
- 2) Primary flow equal to secondary
- 3) Primary flow less than secondary

A simple statement best describes this rule of thumb: flow into a tee must equal flow away from the tee.

#4 Flow-Control Valves

Flow-Control valves are recommended to prevent any flow into the secondary circuit induced by either the slightest pressure drop that may exist on the common pipe or by gravity heads. Because gravity flow can occur within a single pipe, two Flow-Control valves are best, one on the supply and one on the return. However, if the secondary circuit's return is under slung, only one valve is needed.

Primary/secondary (P/S) piping has established itself as the default piping technique for multi-load hydronic systems. Its ability to "keep the peace" among several simultaneously operating circulators is what makes it the preferred choice over other types of distribution systems.

Myth and Realities of P/S system

One question that repeatedly comes up in discussions of primary-secondary systems is how to select the primary loop circulator. Here are some myths and facts surrounding this question.

Myth 1: The primary loop circulator must be the largest circulator in the system.

Fact: Although the primary pump may be the largest circulator in the system, it may also be the smallest. Its size is determined by the rate of heat production of the system's heat source, as well as the selected temperature drop of the primary loop at design load conditions.

Myth 2: The primary loop circulator must produce a flow rate equal to or greater than the total flow rate of all secondary circuits.

Fact: This is not true. The total of all secondary circuit flow rates may be several times the flow rate in the primary loop.

Myth 3: The primary circulator must be selected so the primary loop will operate with a 20 degrees F temperature drop at design load conditions.

Fact: Also untrue. The temperature drop of the primary loop may be less than or significantly greater than 20 degrees F. The latter case often holds significant advantages in terms of reducing installation and operating cost.

Every circulator in a primary/secondary system operates as if it were installed in an isolated circuit. The primary circulator does not assist in moving flow through any of the secondary circuits, or vice versa. The function of the primary loop is simply to convey the output of the heat source to the secondary circuit "pick up" points, while operating at or close to a selected temperature drop.

System Selection

Because the primary loop in a P/S system always operates as if it were a standalone circuit, selecting a circulator for it is really no different than selecting a circulator for any other hydronic circuit. The steps are:

1. Determine the rate of heat delivery available from the heat source.
2. Pick a target temperature drop for the primary loop.
3. Calculate the primary loop flow rate needed based on 1 and 2.

4. Estimate the head loss of the primary loop at this flow rate to get the operating point.
5. Select a circulator with a pump curve passing through or just above this operating point.

Using this approach and under the right conditions, pumping horsepower can be saved initially and in the future. Zones close to the chiller plant are not over headed (over-pressurized) to meet the demands of the zones farther downstream. Zones may be a collection of coils, air handlers, or entire buildings. The operator of the distribution system is isolated from the users and is not subjected to potential excessive static pressure.

Note that a primary loop circulator can be selected without reference to the secondary circuits. Likewise, each secondary circulator can be selected based solely on the flow and head loss requirements of the secondary circuit it serves.

Let's examine the application of Primary –Secondary pump system configuration to the air-conditioning chilled water systems...

Primary-secondary zone pumping systems

The primary-secondary zone pumping system provides significant power savings by automatically controlling the speed of the secondary pumps based on the actual building system demand.

Typically, differential pressure transmitters are placed across building cooling system zones. The transmitters signal to the controller, which controls a variable frequency drive for each variable speed, secondary, chilled water pump. Chilled water return is supplied to the system chiller(s) at a standard 54°F by use of constant speed, primary centrifugal pump(s) that are sized to meet specific demands.

The system works in closed loop and provides air-free chilled water, while automatically refilling under normal system losses. The system also allows for system thermal expansion based on the building system volume. Once the chiller(s) have cooled the chilled water to 44°F, variable speed, secondary chilled water pump(s) supply the chilled Water to the building system. *Variable Frequency Drives* may incorporate manual or automatic bypasses.

This configuration is also referred to as distributive pumping. Zones close to the chiller plant are not over headed (over-pressurized) to meet the demands of the zones farther downstream and the single main distribution pump common in conventional systems is eliminated in favor of multiple zone or building pumps.

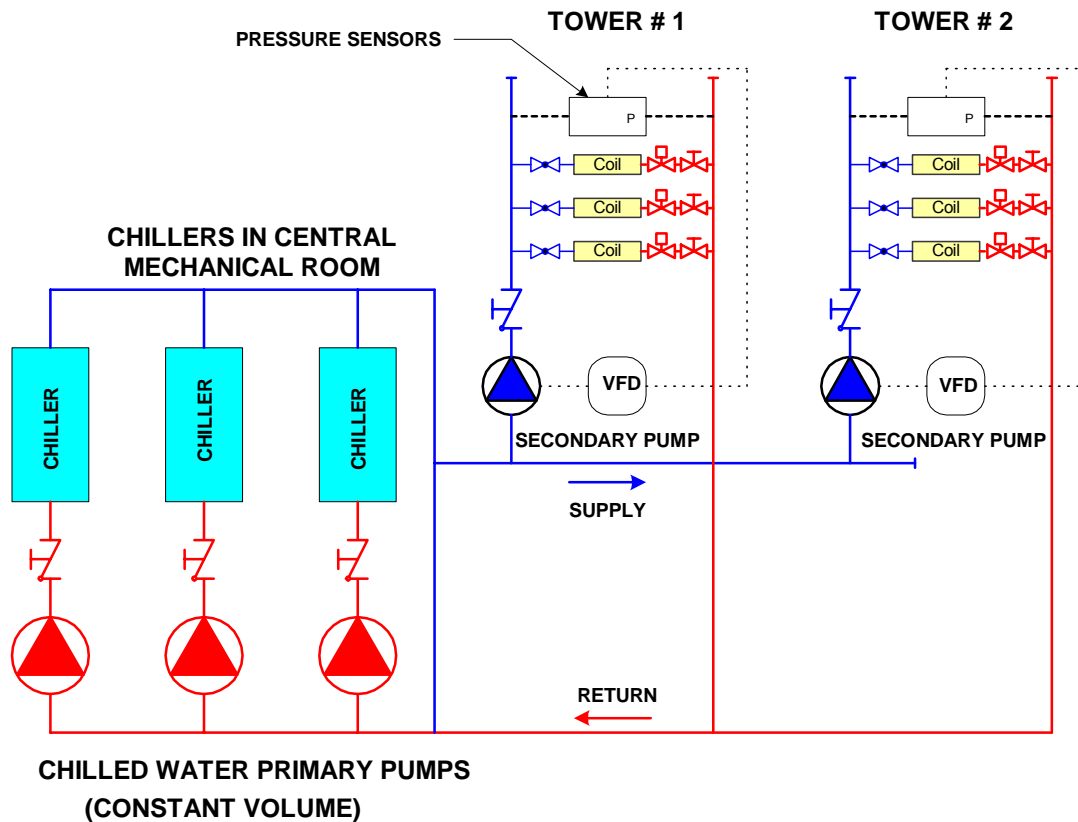

In this scheme, each zone pump is decoupled from the chiller pumps through a common pipe. They are, however, not decoupled from each other. Essentially, they operate in parallel. The suction and discharge of the pumps are connected through shared supply and return piping. A very small pressure drop must be maintained in the pipe shared by these pumps. This pipe includes the common pipe and the shared supply and return header. The designer must be extremely careful with the selection of the pumps and the balancing of each zone. Ideally the pumps should have the same or similar pump curves.

Primary variable speed pumping systems

The concept here is to eliminate secondary pumps to reduce first cost, space requirements, and maintenance. Constant volume is no longer maintained through the

chillers. Primary variable speed pumps are selected in a manner similar to secondary pumps in primary-secondary pumping systems.

Variable system flow is directly achieved through the modulation of flow through the chillers. Primary variable speed pumping systems are especially attractive in primary-pumped retrofit situations since space may not be available for additional pumps and piping.

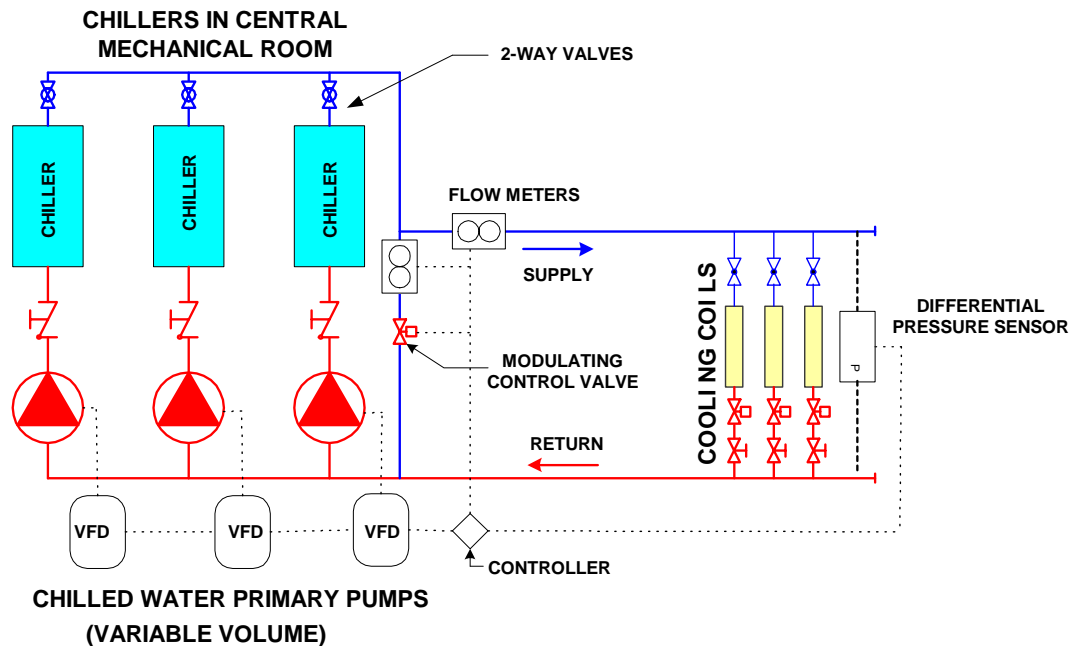

The variable primary flow (VPF) chilled water system is a tested system that provides significant power savings by use of a variable speed pump to simultaneously provide water to the chiller and to the building system. *Variable Frequency Drives* automatically control the speed of the pumps based on actual building system demand.

Control logic and sequencing for the pumps and chillers is the heart of this type of system. With the advent of more sophisticated microprocessor controls, the potential problems associated with under flowing or overflowing the chillers can be addressed. Typically, differential pressure transmitters are placed across building cooling system zones. The transmitters signal to the VPF system controller, which controls a *variable frequency drive* for each variable speed, chilled water pump. Minimum required chiller flow is automatically maintained by a flow meter mounted on the inlet of each chiller. The system chillers cool the chilled water to 44°F and are automatically staged on/off based on actual building system demand from controllers energy consumption monitor.

The common pipe is not eliminated in primary variable speed pumping. It is modified into a low-flow bypass. To ensure that minimum flow is always maintained through the chiller, a bypass with a modulating control valve is employed. As loads diminish, system flow reduces. When the system flow approaches the minimum flow requirement of the chiller, the modulating two-way valve in the bypass opens. The sum of the flow in the system plus the flow in the bypass must exceed the minimum flow requirement of the chillers. Flow meters are installed in both the supply and the bypass to calculate the flow sequence.

Actual building system energy consumption is displayed on the controller's touch screen operator interface. *Variable Frequency Drives* may incorporate Manual or Automatic bypasses. Each system can be custom engineered and designed to meet specific system requirements. Close coordination with the chiller manufacturer is highly recommended, especially in retrofit applications.

Variable flow balancing

Variable flow systems that use two-way valves at either cooling, or heating coils can be balanced by various methods. Two balancing options seemed to provide the best results: the "no balancing" option and the "oversized main piping" option. The no-balancing functions well because, "if the coils are able to achieve their set points at the coil design flow rate or less, then the control valves themselves will dynamically and automatically balance the system." The oversized main piping design reduces over-pressurization of coils close to the pumps, lowers pump energy requirements, and increases long-term system flexibility for adding more coils in the future.

Direct return variable flow hydronic systems (VFHS) must be designed to be self-balancing. However, in practice many design engineers will use customary pipe sizing routines, piping detail drawings, and specifications that apply to more familiar constant flow systems. Substituting a 2-way valve in place of a 3-way valve and bypass pipe, while retaining the balancing valve and balancing specification ultimately creates control problems and energy waste. The use of balancing valves on VFHS is detrimental to the performance of the system because it reduces the authority of the control valve and adds a permanent restriction in every branch. This restriction increases the pumping costs for the life of the building.

The working pressures for VFHS are always higher than for equivalent constant flow hydronic systems (CFHS). On many VFHS the use of conventional HVAC control valves may not be suitable. Specifications for VFHS must stress the importance of the valve actuator and the need for high quality valve bodies to withstand the additional dynamic forces and static pressures that are present in these systems.

In order for a VFHS to be self-balancing, the sensor controlling the coil valve must always be in control of the flow. This is generally the condition when the supply air thermostat controls the coil valve on a variable air volume air-handling unit.

In summary:

1. Use valves with equal percentage ports.
2. Size all branches for approximately the same pressure drop.
3. Size all valves so that the pressure drop through the open valve at design flow is equal to or greater than the drop in the rest of the branch.
4. Select all valve actuators to close off against a differential pressure at least 1 1/2 times the design pump head.
5. Select valve bodies that have a dynamic differential pressure rating at least 1 1/2 times the design pump head.
6. Minimize the pressure drop in the mains and branch piping. Take as much drop across the control valve as practical.
7. Keep the pressure rise ratio below 10.
8. Select valve bodies with static ratings greater than the static hydronic head, plus the compression tank reserve pressure, plus the pump cut off head, at maximum pump speed.

2 WAY VALVE V/s 3 WAY VALVES

High cost of energy leans towards the use of 2-way valve (variable flow) in favor of 3-way control valve (constant flow). Variable volume pumping systems propose high order of pumping power savings while increasing 2-way valve controllability. The pressure difference across the 2-way modulating control valve on variable flow system vary from the differential pressure when the fully opened valve is handling design flow, up to the highest differential pressure when the valve is closed. Because of the wide range in pressure differentials, valve sizing on variable flow systems is extremely important. The

valve should be selected so that the pressure drop across the valve is at least half the drop in the coil branch. The valve will not have enough authority to modulate properly if less drop is taken across the control valve than across the other components in the branch. Valve drops greater than this are a plus for controllability since the valve has more authority, but a minus as far as pump energy is concerned. A valve sized for half the drop of the branch is a conservative compromise.

2-way valve is best when applied with variable speed pumps. Rather variable-pumping systems should only use 2-way valve to reap the energy saving benefits.

The constant volume systems may employ 2-way or 3-way valve. While pumping costs will decrease to small amount with 2-way valve, other problems occur. The 2-way valves with constant volume system may some time lead to balancing problems in large network and may lead to water scarcity at some terminal locations. The pumps must incorporate the minimum recalculating system should the 2-way valve/s close to 100% close position. The systems incorporating 3-way valve ensure continuous circulation.

The power savings with 2-way valve with constant volume and variable volume system is depicted below:

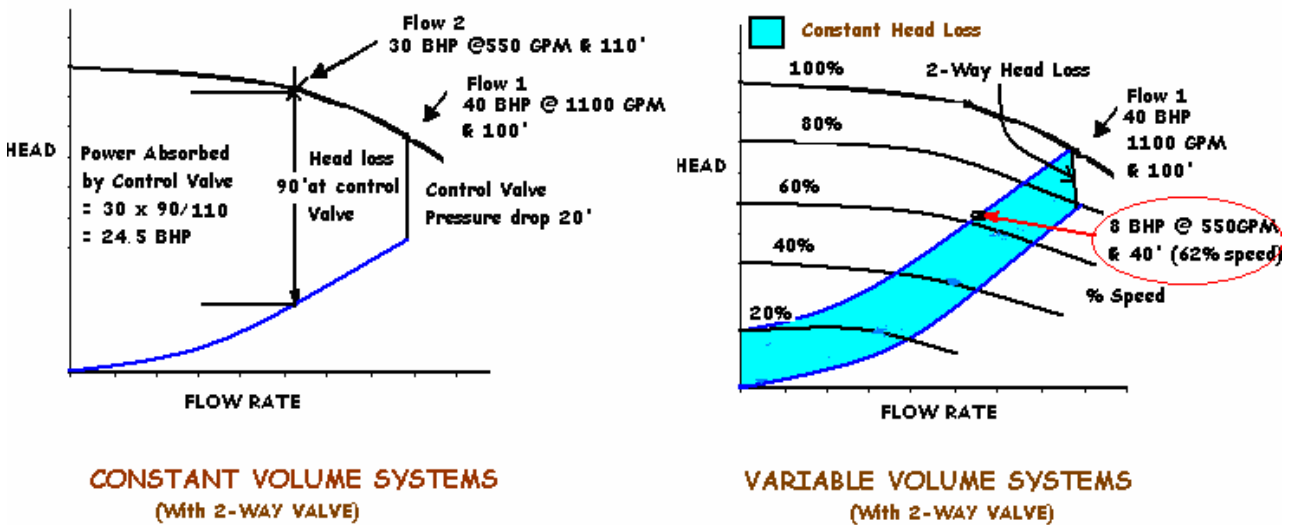

Figure above shows that with variable pumping as the pump speed decreases to achieve 50% flow, pump power requirement shall reduce to about 8 BHP in comparison to 30 BHP as needed for the constant speed pump at this flow condition; an 80% reduction.

BALANCING VALVE LOCATION

Which side should you put your balancing valve – Supply side or Return Side?

Whenever possible, balance valves should be placed on the return side of coils to reduce air and noise problems.

ASHRAE states that "water velocity noise is not caused by water but by free air, sharp pressure drops, turbulence, or a combination of these, which in turn cause cavitation or flashing of water into steam" (1997 ASHRAE Fundamentals Handbook, page 33.4).

Compared with placement on the supply side, balance valves on the return side will reduce the amount of free air in the coil.

At a given temperature, the amount of air in water depends on pressure. If the water pressure is reduced, air is released. A diver experiences this phenomenon if he quickly decreases the pressure on his body by ascending quickly to the surface. A rapid decrease in pressure will cause gases to come out of solution of blood and tissue, causing pain and possible damage. This is known as "the bends."

Balance valves placed on the return side will result in higher water pressures within the coil, which means that more air will remain in solution and out of the coil (see figures below). In each figure, the coil pressure drop is 20 ft.

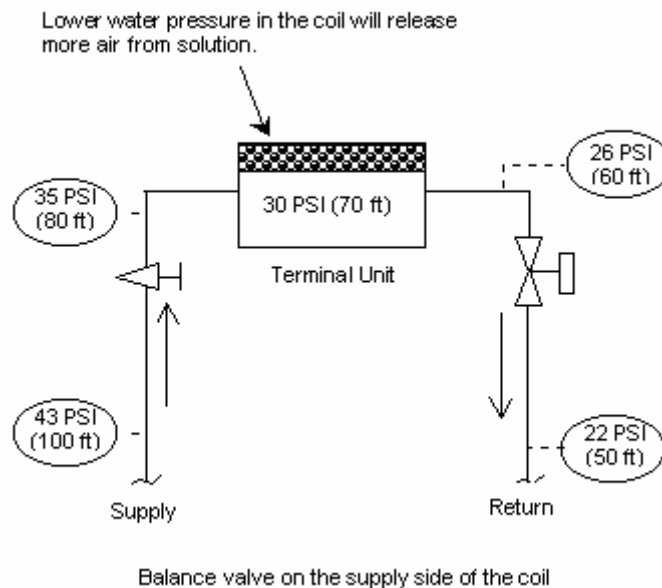

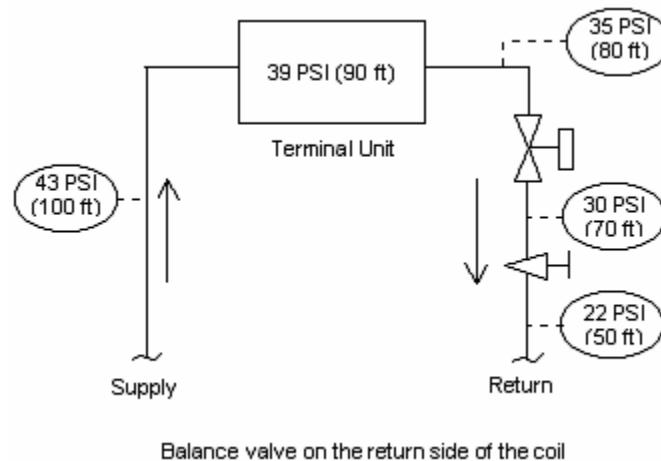

Note that the flow balancing effect of the valve is the same in either case. That is, the overall circuit pressure drop is the same, which will result in the same flow through the coil.

The balancing valves should be carefully evaluated for variable volume systems and should be avoided as it may interfere with the operation of 2-way modulating valve.

ENERGY EFFICIENT MOTORS

The average electric motor will consume its capital cost in energy in less than 2 months, typically a motor, costing \$500 will consume over \$50000 in its lifetime. Therefore a single percentage point increase in efficiency will save lifetime energy cost generally equivalent to the purchase price of the motor. This illustrates the importance of giving close attention to efficiency criteria.

The calculation for the energy cost per annum of any electric motor is:

Hours used per year x kWh tariff x operating point kW ÷ Efficiency at operating point

Example:

Typically for a pumping system: -

Design duty point 80 kW Installed motor rating 90 kW

Operating point 67.5 kW Operating 6000 hrs/yr

Motor efficiency 95.0% Tariff \$ 0.1/kWh

Energy cost = 6000 x \$0.1 x 67.5/ 0.95

= \$ 42631 per year

Using this formula, comparisons can be made between different types of motor. Based on a typical fourteen-year life of an electric motor, lifetime cost savings for high efficiency motors are in the order of 3-4 times the purchase cost.

Efficiency depends not only on motor design, but also on the types and quantity of active materials used. The efficiency can therefore vary considerably from manufacturer to manufacturer.

Manufacturers have focused on the following key factors to improve the efficiency of a motor.

- Electromagnetic design – Making the best use of copper by winding techniques and lamination design
- Magnetic steel – Utilizing a low loss, high permeability steel
- Thermal design – Ensuring optimum fit between stator, frame and laminations.
- Aerodynamics – Using a more efficient cooling system by change of fan and/or fan cover design.
- Manufacturing quality – Improving assembly techniques

By adopting these techniques, manufacturers have made efficiency improvements in the range of 3%, on motors up to 400kW. The percentage gains on the lower kW output motors could be greater than 3%, the gains on the higher kW output motors will not be as great.

There are several international standards for measuring the efficiency of a motor. European (IEC 34) and North American (IEEE 112) standards vary and will inevitably produce differing results.

In comparing any manufacturers' data, the supply input and test method utilized must be common to each set of data.

Often pump and motor are sold as a package. Often, however the buyer can select one of several motors to install with a pump. Motors that are not large enough may have to operate above their rated load, forcing them to run at elevated temperatures, which shortens their operating lives. Motors those are much larger than required not only cost more, but also suffer efficiency loss when the operating load falls beneath about one half of the motors rated load.

Motors used in connection with VFD should have properly insulated windings to handle the harmonics and other power quality issues associated with VFDs. Inverter duty or definite purpose motors will provide this protection.

Soft Starting and Stopping

When an induction motor is started direct on line, it will generate a high level of torque, which will cause a very fast breakaway, and it will then accelerate up to speed in an uncontrolled fashion.

In this case the network has to supply a large inrush current, a very high initial level to establish flux in the motor, followed by a high level, which decreases as the drive accelerates.

The effect on the pump is to place mechanical stresses on the rotating components, followed by stresses in the hydraulic system, which may include a high initial flow rate causing a vacuum to be drawn on the suction side, or surge on the discharge, and possible NPSH problems.

Equally when stopping - the rate of deceleration is totally uncontrolled; this can lead to further mechanical stresses, and surges in the hydraulic circuit. This can lead to requirements for additional inertia added to a pump, generally in the form of a flywheel, or to surge control vessels in the hydraulic system.

The use of electronic starting systems allows smooth acceleration and deceleration of a drive system.

Electronic soft starters will reduce the voltage at the motor terminals in a controlled manner, but are generally short time rated devices, while a frequency converter is usually continuously rated and so can be used to give very controlled rates of change.

The only drawback with either electronic scheme is that generally the equipment must be connected to the network, and therefore problems of uncontrolled deceleration could arise in a power failure.

PUMP SYSTEM DESIGN- GENERAL RECOMMENDATIONS

Efficient pumping system designs begin with a systemic viewpoint. Using larger diameter pipes is only the first step: smaller pumps and motors, larger check and isolation valves; low-pressure-drop components; smaller, less-expensive motor-drive circuits and

electrical components all contribute to energy and cost efficiency. It is also equally important to optimize the piping system's layout, i.e., a "clean" layout is an efficient layout. With this approach, equipment is placed *after* the piping is optimized, which will increase the amount of straight runs and decrease convoluted runs. Added benefits of a clean piping layout include less piping insulation and lower overall cost and time to construct.

The proper design and installation of pump can have significant impact on its long-term performance. When designing new system with centrifugal pumps here are a few things you may want to consider.

Pump System Design/Selection

- ✓ Design systems with lower capacity and total head requirements. Do not assume these requirements are fixed.
- ✓ Do not oversize pumps. Give yourself an additional 5% or 10% you might need it. The Hydraulic Institute recommends using two or more smaller pumps instead of one larger pump, so that excess pump capacity can be turned off. It typically will be less expensive to add pumping capacity later if requirements increase.
- ✓ Install parallel systems for highly variable load, or install a larger pump with speed controls (10%–50% savings).
- ✓ Flow capacity, for example, can be reduced through use of lower velocity in heat exchangers and elimination of open bypass lines. Total head requirements can be reduced by: lowering process static gage, pressure, minimizing elevation rise from suction tank to discharge tank, reducing static elevation change by use of siphons, lowering spray nozzle velocities, lowering friction losses through use of larger pipes and low-loss fittings, and eliminating throttle valves.
- ✓ Note that small differences in efficiency between pumps are not as important as knowing and adjusting to the service conditions. Energy savings may be as high as 20% if pumps are sized based on reasonable system heads and capacity requirements. Savings result from operating at a more efficient point on the pump curve, and in some cases, this also avoids the need to throttle pump capacity or operate at a higher capacity than necessary.

- ✓ Use variable-speed drives to avoid losses from throttle valves and bypass lines, except when the system is designed with high static heads. It is more efficient and results in longer pump life.
- ✓ In such instances, extra concern must be shown when calculating the savings, since the pump affinity laws cannot be used without regard to the change of pump (and motor) efficiency along the system curve. Take care to ensure that the operating point of the pumps remains within the allowable/recommended limits specified by the pump manufacturer.
- ✓ Pumps piped in series must have the same capacity (impeller width and speed).
- ✓ Pumps piped in parallel must have the same head (impeller diameter and speed).
- ✓ Use two or smaller pumps instead of one larger pump so that excess pump capacity can be turned off.
- ✓ If more flow is required, two pumps can be operated in parallel during peak demand periods, with one pump operating by itself during lower demand periods. Energy savings result from running each pump at a more efficient operating point and avoiding the need to throttle a large pump during low demand. This also ensures systems reliability should one pump require servicing. An alternative is to use one variable-speed pump and one constant-speed pump.
- ✓ Do not try to select pumps with excessively low required NPSH (Net Positive Suction Head). Do not falsify real available NPSH, trying to keep a margin up your sleeve. This leads to selection of pumps with excessively high suction specific speeds and high minimum flows.
- ✓ Do not use a mechanical seal when packing is more than adequate for the intended service.
- ✓ For a systems where requirement are quite fixed and do not warrant wide variations, choose a pump that can give you the required flows at the highest efficiency or lowest possible power consumption. Since pumps often operate continuously, the power consumption (watts - not amps), and its effect on your monthly utility bill can be very significant.

Piping Design & Installation

A piping system if improperly designed or poorly installed can promote the formation of air pockets or vortices that may impede flow. Piping that runs into the suction inlet should be very straight since disrupted flow can impair pump efficiency and performance. In addition, the piping should be well aligned with the pump connections. A common tendency during installation is to force connections to fit rather than carefully readjusting the location of the pump or the piping. Force fitting a misaligned connection can distort the pump housing, creating a harmful load condition on the pump shaft and bearings.

Friction Losses

In the fluid system, unnecessary friction can increase energy use. As fluids flow through pumps, pipes and fittings, there is resistance, resulting in a decrease in pumping pressure and velocity, which adversely affects pumping efficiency.

The amount of energy lost due to friction depends on a number of factors. The losses are caused by the following:

- Friction between the fluid and piping walls
- Friction between the adjacent fluids (higher viscosity fluids have higher losses)
- Amount of surface roughness on the interior of the pipes
- Turbulence created when redirecting the fluid, via a bend in the pipe or a restriction, such as a valve, fitting or reducer

The higher the flow rate and the smaller the pipe, the higher the resistance—and the higher the friction and its resultant effects on energy loss. System design is also a major consideration when limiting friction and increasing efficiency. The longer the pipe in which the fluid must travel, the more energy-robbing friction is produced. Also, bends, kinks, sharp turns or anything that changes the flowing fluid's course of motion in the piping create more friction, so they must be minimized.

The Solution

Basically, four possible methods are available to reduce friction losses in a piping system:

- Increase the pipe diameter of the system.

- Minimize the length of the piping within the system.
- Minimize the number of elbows, tees, valves, fittings and other obstructions in the piping system, while simplifying the layout as much as possible. If a corner must be turned, a gentle bend is better than a sharp, 90-degree turn.
- Reduce the surface roughness of the piping in the system.

Remember, installing larger diameter pipe in pumping system results in reduction in friction head. Static head remains unchanged, which is dependent on the elevation.

Some good practices are:

- ✓ Locate the pump as close to the source as possible. It is best to have your main (longest) run of pipe on the discharge side of the pump. The pump is designed to push water, not pull it.
- ✓ There should be at least 10 diameters of pipe between the suction of the pump and the first elbow. This is especially critical in double ended pump designs as the turbulent inlet flow can cause shaft thrusting, and subsequent bearing problems.
- ✓ Keep the suction piping as short as possible, and avoid air traps by ensuring that the pipe can be installed to rise uniformly to the pump suction. For example, try to avoid suction piping that “loops” vertically as it goes to the pump.
- ✓ Try to avoid condenser fouling and pump air problems by including low pressure drop solids and air removal devices in the suction piping. Remember that there are limits to the amount of dynamic suction lift that a centrifugal pump can achieve. A good rule of thumb is to design for a maximum dynamic suction lift of 15 ft.
- ✓ Air trapped in a piping system can make priming a centrifugal pump difficult. Therefore, the installation of the suction line from the water source to the inlet side of the pump should be on a slight incline in order to remove unwanted air pockets.
- ✓ Substituting a globe valve for a gate valve in a piping system is similar to adding another 100 feet (31 meters) of piping to the system. On the discharge side of the pump this will cause the pump to run off of its best efficiency point (BEP) with

a resultant shaft bending. On the suction side of the pump it will probably cause Cavitation.

- ✓ Use eccentric reducers rather than concentric reducers at the pump suction. Concentric reducers will trap air. Be sure the eccentric reducer is not installed up side down.
- ✓ Consider installing unions on a pump to prevent priming problems. However, the location of the union should be between the pump's check valve and the pump, not between the check valve and the water source. Unions may be a source of a vacuum leak, which could cause the pump to lose its prime.
- ✓ When installing unions, alignment and a non-stress fit are critical. If the union is installed between the check valve and the pump, and a vacuum leak occurs, then the pump will likely have poor pump performance, but not a loss of prime. However, if the union is installed between the check valve and the water source and the union fails, loss of prime is inevitable.
- ✓ Locate the pump at an elevation as close to the suction source as possible to minimize suction lift and minimize priming problems.
- ✓ Always have your inlet pipe diameter equal to, or larger than, the discharge line. This helps prevent cavitation.
- ✓ Remember, the size of the pump's suction and discharge ports does not indicate your proper pipe size. Minimize friction losses by using large diameter pipe. Determine the approximate flow rate you want, and the total length of your pipe. Choose a pipe diameter that keeps your friction loss below about five feet per hundred feet of pipe.
- ✓ A good place to look for savings in pump-head design is in the supply and return mains. This is because an increase in pipe size in these mains will improve the system "balance ability."
- ✓ Make sure all your pipe joints are airtight. This is especially important on the suction side. Use Teflon paste (not tape) for sealing threaded joints.
- ✓ Do provide sufficient submergence over intake piping to prevent vortex formation.
- ✓ Do not use suction elbows in a plane parallel to the shaft; place them in the plane perpendicular to the shaft.

- ✓ Do not use the pump casing as an anchor for the piping. If you use expansion joints, supports and anchor them independently of the pump.
- ✓ Do provide adequate flow, pressure and temperature instrumentation for each pump.
- ✓ Pump and driver alignment must be rechecked under normal operating conditions.
- ✓ Use a filtration system that does not require a lot of pressure. It costs money to create pressure. Biological filters work well and require very little pressure.
- ✓ Fittings should be provided to permit the installation of vacuum and pressure gauges on each side of the pump if provision has not already been made in the pump for these gauges.
- ✓ Never allow out-of-pond centrifugal pump and motor unit to become submerged. Use a GFI circuit for protection. If this ever accidentally occurs, shut the unit down, disconnect it, and have a reputable service shop examine the motor before re-using it.
- ✓ Install shut off valves before and after the pump, so you can easily remove it from the line without having to drain your system.
- ✓ Quick-closing valves or nozzles should not be used on the discharge lines.
- ✓ A check valve should be installed in the discharge line as close as possible to the pump when the static discharge head exceeds 25 feet.
- ✓ On installations involving suction lift a good foot valve or line check, located at the beginning of the suction lift or an angle check valve at ground level will help insure flow as soon as pump is started.
- ✓ If it is not possible to provide a flooded suction installation then:
 - Position the pump as low as possible, and as near the source as possible. (A pump one foot above the surface works better than one six feet above the surface.)
 - Install basket strainer on the inlet of the pump or provide some other priming source.
 - Suction piping should slope gently upward to the pump or strainer inlet.

- Install a foot valve, in the inlet line below the water level.
- Always prime the entire inlet line, basket strainer, and pump before turning it on.

Operation

- ✓ Never run a pump dry. This may damage the mechanical seal and impeller. They are designed to pump fluid, not air. Insure the pump is full of water before you turn it on, and that it doesn't out pump the supply. Note: if you have purchased a dry run seal, it can run without water for a limited period of time.
- ✓ Don't use seal if the duty can be met by simple packing.
- ✓ Do not operate pumps below the recommended minimum flow.
- ✓ Do not operate pumps with suction valve closed.
- ✓ Do not run two pumps in parallel when a single pump can carry the reduced system load.
- ✓ Do not stop a pump while it is activating. Re-establish 'normal operation first and then stop' the pump if you have to.
- ✓ A pump handles liquids. Keep air out.
- ✓ Do not run a pump if excessive noise or vibration occurs.
- ✓ Do run spare pumps occasionally to check their availability.
- ✓ Cover the pump and motor unit with a suitable shelter. When protected from rain and dust the motor will last longer. The covering should allow the motor to have suitable air recirculation for proper cooling.
- ✓ If your pump is producing too much flow, you can reduce the flow by partially closing a valve on the discharge line. Never restrict the inlet!!! Always allow a couple gallons per minute to flow to prevent heat build up inside the pump housing.

Maintenance

Maintain pumps and all system components in virtually new condition to avoid efficiency loss. Wear is a significant cause of decreased pump efficiency. Bearings must be properly lubricated and replaced before they fail. Shaft seals also require consistent

maintenance to avoid premature mechanical failures. Most important is the renewal of internal wearing ring clearance and the smoothness of impeller and casing waterways.

- ✓ Run a performance test at reasonable intervals of time, to follow effect of increased internal clearances.
 - ✓ Do not open pumps for inspection unless factual or circumstantial evidence warrants it.
 - ✓ Do not over lubricate grease-lubricated bearings.
 - ✓ Do not tighten stuffing box glands excessively. Let enough leakage flow to cool and lubricate packing.
 - ✓ Do monitor the pressure drop across suction strainers. An excessive pressure drop indicates clogging and may reduce available NPSH to a dangerous degree.
 - ✓ Keep an adequate stock of spare parts.
 - ✓ Except in an emergency, use original equipment manufacturer's replacement spares.
 - ✓ Consider upgrading material for parts that wear or corrode too rapidly. This lengthens interval between overhauls.
 - ✓ Examine and recondition, if necessary, all metal-to-metal fits.
 - ✓ Examine parts for corrosion, erosion or other damage.
 - ✓ Check concentricity of all parts of the rotor before reassembly.
 - ✓ Use new gaskets for complete overhaul.
 - ✓ Wear is a significant cause of decreased pump efficiency. Bearings must be properly lubricated and replaced before they fail. Shaft seals also require consistent maintenance to avoid premature mechanical failures. Most important is the renewal of internal wearing ring clearance and the smoothness of impeller and casing waterways.
 - ✓ Maintain pumps and all system components in virtually new condition to avoid efficiency loss.
-

Course Summary

Pumps are not the biggest consumers of energy, but they're not the smallest either. A little extra effort in the system design and equipment selection can make a worthwhile difference. The complexity associated with selecting a pump often results in a pump that is improperly sized for its application. Selecting a pump that is either too large or too small can reduce system performance. Under sizing a pump may result in inadequate flow, failing to meet system requirements. An oversized pump, while providing sufficient flow, can produce other negative consequences:

- Higher purchase costs for pump and motor assembly
- Higher energy costs, because oversized pumps operate less efficiently and
- Higher maintenance requirements, because as pumps operate further from their BEP they experience greater stress

Ironically, many oversized pumps are purchased with the intent of increasing system reliability. Unfortunately, conservative practices often prioritize initial performance over system life cycle costs. As a result, larger than necessary pumps are specified, resulting in systems that do not operate optimally. Increased awareness of the costs of specifying oversized pumps should discourage this tendency.

In systems that experience wide variations in demand, pumps are sized for the maximum anticipated flow rate and the system efficiency depends on configuring a pump or set of pumps. The most frequent means of varying the pump performance is to have a line which re-circulates flow back to the suction tank. Another method is to have a valve in the discharge line, which reduces the output flow rate when throttled. Either method works well, but there is a penalty to be paid in consumption of extra power for running a system, which is oversized for the normal demand flow rate. A solution to this power waste is to use a variable speed drive (VSD), which yields good payback in the majority of applications even though the capital expenditure is relatively high. The implication of the squared and cubic relationships of head and power absorbed is that relatively small changes in speed give very significant changes. VSDs provide power savings at a cubed rate.

To handle wide variation in flow, multiple pumps are often used in parallel configuration. This arrangement allows pumps to be energized and de-energized to meet system needs. One way to arrange pumps in parallel is to use two or more pumps of the same

type. Alternatively, pumps with different flow rates can be installed in parallel and configured such that the small pump – often referred to as the pony pump operates during normal conditions while the larger pump operates during periods of high demand.

In general, the following should be remembered:

- ✓ Match the pump type to the intended duty
- ✓ Don't oversize the pump
- ✓ Match the driver type to the intended duty
- ✓ Specify motors to be high efficiency
- ✓ Adjustable-speed pump drives provide deep energy savings, but aren't appropriate everywhere.
- ✓ Incorporating primary/secondary and even tertiary piping loops facilitates load matching, increasing energy savings.
- ✓ Match the power transmission equipment to the intended duty economic impacts of pipe sizing and valve selection are important. Bigger pipes and low-loss valves reduce operating costs significantly.
- ✓ Evaluate system effectiveness
- ✓ Monitor and sustain the pump and system to maximize benefit
- ✓ Consider the energy wasted using control valves
- ✓ Install and operate pumping systems on manufacturer's guidelines and established best practices.

Once you finish studying the above course content, you need to take a quiz to obtain the PDH credits.