

---

# Coastal Construction - Constructing the Building

Course No: S04-007

Credit: 4 PDH

---

Gilbert Gedeon, P.E.

---



Continuing Education and Development, Inc.  
9 Greyridge Farm Court  
Stony Point, NY 10980

P: (877) 322-5800

F: (877) 322-4774

[info@cedengineering.com](mailto:info@cedengineering.com)

---

---

# Chapter 13: Constructing the Building

## Table of Contents

	Page
13.1	Introduction ..... 13-1
13.2	Foundation Construction ..... 13-2
13.2.1	Layout ..... 13-2
13.2.2	Soils ..... 13-6
13.2.3	Pile Foundation ..... 13-9
13.2.4	Masonry Foundation Construction ..... 13-15
13.2.5	Concrete Foundation Construction ..... 13-17
13.2.6	Wood Foundation Construction ..... 13-19
13.2.7	Foundation Material Durability ..... 13-20
13.2.8	Field Preservative Treatment ..... 13-25
13.2.9	Substitutions ..... 13-26
13.2.10	The Top Foundation Issues for Builders ..... 13-26
13.2.11	Inspection Points ..... 13-27
13.3	Structural Frame ..... 13-27
13.3.1	Floor Framing ..... 13-31
13.3.2	Wall Framing ..... 13-34
13.3.3	Roof Framing ..... 13-38
13.3.4	The Top Structural Frame Issues for Builders ..... 13-40
13.4	Building Envelope ..... 13-41
13.4.1	Substitution of Building Envelope Materials ..... 13-42
13.4.2	Building Envelope Inspection Points ..... 13-42
13.4.3	The Top Building Envelope Issues for Builders ..... 13-43
13.5	Appurtenant Structures ..... 13-44

13.5.1	Decks .....	13-44
13.5.2	Storage Buildings .....	13-46
13.5.3	Swimming Pools and Hot Tubs .....	13-46
13.5.4	Walkways and Sidewalks .....	13-48
13.6	Utility/Mechanical Equipment .....	13-49
13.6.1	Elevators .....	13-49
13.6.2	Heating, Ventilating, and Cooling (HVAC) Systems ....	13-50
13.6.3	Electrical Systems .....	13-53
13.6.4	Water and Wastewater Systems .....	13-53
13.6.5	Tanks .....	13-54
13.7	References .....	13-55

## Figures

Figure 13-1	Site layout. ....	13-3
Figure 13-2	Typical pile notching process. ....	13-4
Figure 13-3	Overnotched pile. ....	13-4
Figure 13-4	Properly notched pile. ....	13-5
Figure 13-5	Plan view of foundation showing techniques for squaring a building. ....	13-6
Figure 13-6	Damage caused by slope failure. ....	13-8
Figure 13-7	Typical wood-pile foundation. ....	13-9
Figure 13-8	Diagonal wood bracing in a wood-pile foundation. ....	13-12
Figure 13-9	Knee bracing in a wood-pile foundation. ....	13-13
Figure 13-10	Open masonry foundation. ....	13-16
Figure 13-11	Concrete foundation. ....	13-17
Figure 13-12	Concrete house. ....	13-18
Figure 13-13	Wood decay at the base of a post supported by concrete. ....	13-21
Figure 13-14	Minimizing the least dimension of wood contact surfaces. ....	13-22

Figure 13-15	Drip cut minimizes horizontal water movement along the bottom surface of a wood member. ....	13-24
Figure 13-16	Exposure of end grain in stair stringer cuts. ....	13-24
Figure 13-17	Deterioration in a notched stair stringer. ....	13-24
Figure 13-18	Alternative method of installing stair treads. ....	13-25
Figure 13-19	Hurricane Iniki (1992), Hawaii. Connector failure caused by insufficient nailing. ....	13-28
Figure 13-20	Reinforcement of overnotched piles. ....	13-29
Figure 13-21	Beam support at misaligned piles. ....	13-30
Figure 13-22	Proper pile notching for two-member and four-member beams. ....	13-30
Figure 13-23	Metal twist strap ties (circled). ....	13-31
Figure 13-24	Plywood web I-beams used as floor joists with metal brace used to keep the bottoms of the joists from twisting. ....	13-32
Figure 13-25	Acceptable locations for splices in multiple-member girders. ....	13-33
Figure 13-26	Using full-height sheathing improves transfer of shear. ....	13-35
Figure 13-27	Hurricane Andrew (1992), Florida. Roof sheathing found in debris. ....	13-39
Figure 13-28	Sheathing nails (circled) missed roof rafter in new construction. ....	13-39
Figure 13-29	Building damage from Hurricane Opal at Pensacola Beach, Florida. ....	13-45
Figure 13-30	Stair elevation system. ....	13-46
Figure 13-31	Recommendations for orientation of in-ground pools. ....	13-48
Figure 13-32	Cantilever floor framing for air-conditioning/heat pump compressor platform—plan view. ....	13-51
Figure 13-33	Cantilever floor framing for air-conditioning/heat pump compressor platform – elevation view. ....	13-51
Figure 13-34	Wood-brace-supported air-conditioning/heat pump compressor platform – plan view. ....	13-52

Figure 13-35 Wood-brace-supported air-conditioning/heat pump compressor platform – elevation view..... 13-52

Figure 13-36 Anchoring techniques for aboveground tanks. .... 13-55

**Tables**

Table 13.1 Soil Type Definitions Based on USDA Unified Soil Classification System ..... 13-7

Table 13.2 Engineering Properties of Soil Types Classified by USDA ..... 13-7

Table 13.3 Foundation Inspection Points ..... 13-27

Table 13.4 Floor Framing Inspection Points ..... 13-34

Table 13.5 Wall Inspection Points ..... 13-37

Table 13.6 Roof Frame Inspection Points ..... 13-40

Table 13.7 Building Envelope Inspection Points ..... 13-43

**Formulas**

Formula 13.1 Pile Driving Resistance for Drop Hammer Pile Drivers ..... 13-10

# Constructing the Building

## 13.1 Introduction

Construction of residential buildings in coastal zones presents challenges to the builder not usually found in more inland locations. For all coastal residential buildings, these challenges may include the following:

- connection details require additional inspections
- the need for careful surveying to place the building within property line setbacks and above the Design Flood Elevation (DFE)
- the additional care required to ensure that all elements of the building will withstand the large forces associated with high wind speeds and coastal flooding
- the additional care that must be taken in constructing a building envelope that will withstand the intrusion of air and moisture under the effects of high wind speeds
- the difficulty of providing durable exterior construction in a moist, sometimes salt-laden, environment
- the requirement to protect and, usually, place utilities above the DFE

In constructing coastal residential buildings on elevated pile foundations, builders face additional challenges:

- the difficulty of constructing a driven pile foundation to accepted construction plan tolerances
- the difficulty of building on an elevated post-and-beam foundation, compared to building on continuous wall foundations

This chapter discusses construction aspects of the above challenges, as well as other aspects of the coastal construction process. Individual sections cover construction items that will probably require the most care or attention on the part of the builder in order for the design intent to be achieved.

While much of the discussion concerns constructing the building to meet the architect's and engineer's design intent for current and future conditions, it is also important that the building elements be durable. Wood decay and termite infestation, metal corrosion, and concrete and masonry deterioration can



### NOTE

The National Flood Insurance Program (NFIP) regulations state that for buildings in V zones, “a registered professional engineer or architect shall develop or review the structural design, specifications and plans for the construction, and shall certify that the design and methods of construction to be used are in accordance with accepted standards of practice” for meeting the provisions of the NFIP regulations regarding buildings in V zones (see Chapter 6 of this manual).



### NOTE

Sections of this chapter refer to specific requirements of the 2000 *International Building Code* (referred to as the IBC 2000), prepared by the International Code Council (ICC 2000a). The ICC also prepared the 2000 *International Residential Code for One- and Two-Family Dwellings* (ICC 2000b), referred to as the IRC 2000. Designers should refer to pertinent sections of the IRC 2000, in addition to those of the IBC 2000 cited here.

**NOTE**

If there is a conflict between design drawings and standard code practice, the most conservative should apply.

weaken the building significantly so that it is hazardous to occupy under any conditions and more likely to fail in a severe natural hazard event.

Builders may find that the permitting and inspection procedures in coastal areas are more involved than those in inland areas. Not only must all Federal, state, and local Coastal Zone Management and other regulatory requirements be met, the design plans and specifications may need to be sealed by a design professional. Building permit submittals often must include detailed drawings and information for all the elements of the wind-resisting load path, including sheathing material, sheathing nailing, strap and tiedown descriptions, bolted connections, and pile description and placement. The placement of utilities above the DFE, breakaway walls, and flood equalization openings must be clearly shown. Site inspections will likely focus on the approved plans, and building officials may be less tolerant of deviations from these approved construction documents. Several sections of this chapter identify points for possible inspections.

## 13.2 Foundation Construction

### 13.2.1 Layout

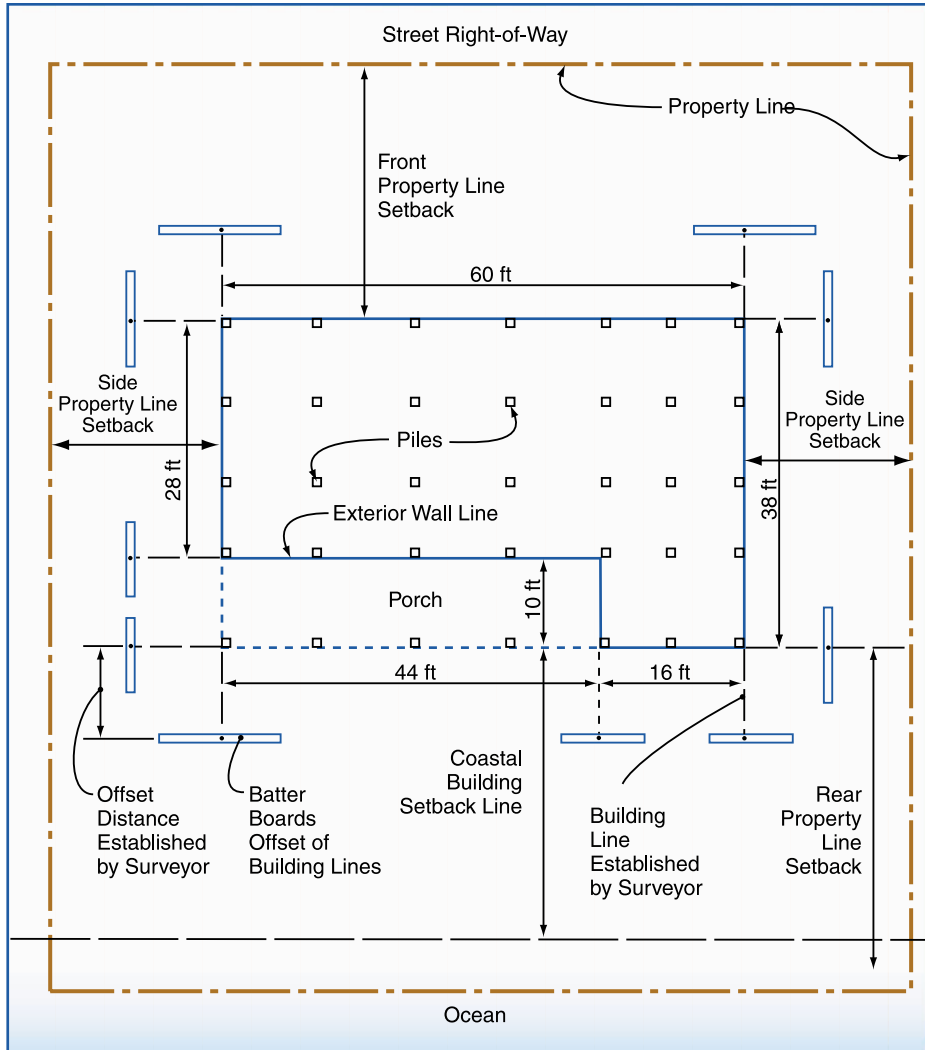
After the permit submittal and approval process is completed, the construction site must be made ready for the foundation construction. Surveying and staking must be done accurately to establish the building setback locations, the DFE, and the house plan and pile locations. Figure 13-1, a site layout illustration that shows pile locations, batter boards, and setbacks, is intended to show the possible constraints a contractor may face in actually laying out a pile-supported structure on a narrow coastal lot. There may be conflicts between what the contractor would like to do to prepare the site and what environmental controls dictate can be done at that site. Leveling of the site, especially altering dunes, and removal of existing vegetation may be restricted. These restrictions may constrict access by pile drivers and other heavy equipment.

In an elevated building with a pile foundation, the layout of the horizontal girders and beams should anticipate the fact that the final plan locations of the tops of the piles will likely not be precise. Irregularities in the piles and the soil will often prevent the piles from being driven perfectly plumb. The use of thick shims or overnotching for alignment at bolted pile-girder connections will often have a significant adverse effect on the connection capacity.

**NOTE**

Foundation design is discussed in detail in Section 12.4.3, in Chapter 12 of this manual.

Figure 13-2 shows the typical process of pile-notching. The use of a chain saw for this process can lead to inaccuracies at this early stage of construction. Figure 13-3 shows a wood pile that is overnotched; Figure 13-4 shows a pile properly notched to support the floor girder, and cut so that there is plenty of wood remaining at the top of the pile.



**Figure 13-1**  
Site layout.

A rule of thumb regarding notching is to notch no more than 50 percent of the pile cross-sectional area. Notching more than this area will require reinforcing the pile with a steel plate (or material of similar strength). Section 13.3 presents additional information concerning the reinforcement of overnotched and misaligned piles.

The primary floor girders spanning between pile or foundation supports should preferably be oriented parallel to the primary flow of potential flood water and wave action. This orientation (normally at right angles to the shoreline) allows the lowest horizontal structural member perpendicular to flow to be the floor joists. Thus, in an extreme flood, the girders would not likely be subjected to the full force of the storm water and debris along their more exposed surfaces.

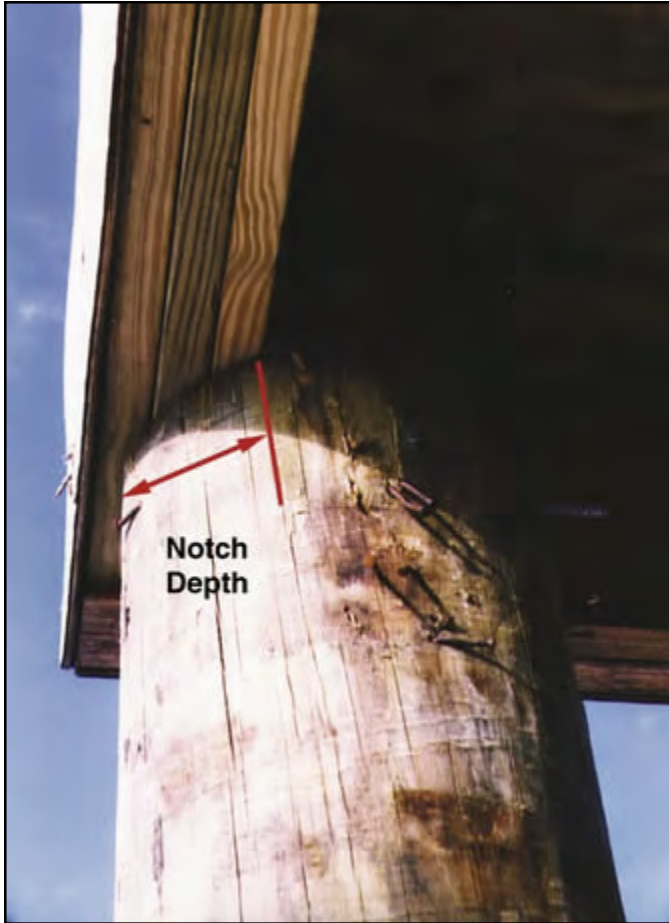


**Figure 13-2**  
Typical pile notching process.  
Photograph by Patty  
McDaniel.



**Figure 13-3**  
Overnotched pile. Also note  
mislocated bolt.

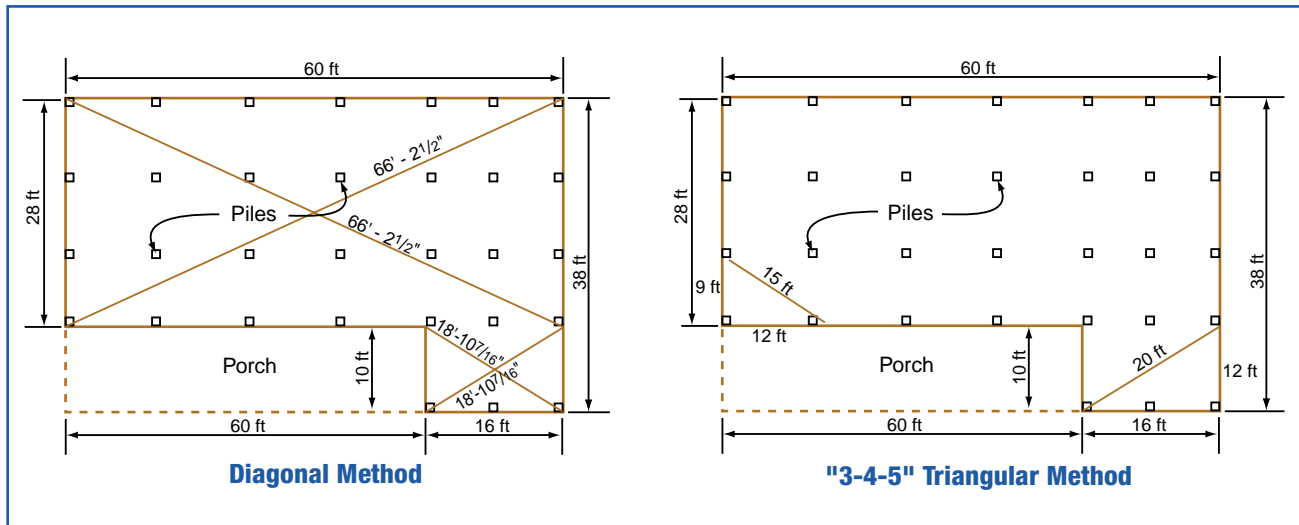


**Figure 13-4**

Properly notched pile. Note that the outer member of this three-member beam is supported by the through-bolt rather than the beam seat.

One of the most important layout steps is to “square” the first-floor framing. The entire structure is built upon the first floor; therefore, it is imperative that the first floor be level and square. The “squaring” process normally involves taking diagonal measurements across the outer corners and shifting either or both sides until the diagonal measurements are the same, at which point the house is square. An alternative is to take the measurements of a “3-4-5” triangle and shift the floor framing until the “3-4-5” triangular measurement is achieved. See Figure 13-5 for an illustration of these squaring methods.

Figure 13-5  
Plan view of foundation showing techniques for squaring a building.



## WARNING

The amount of long-term and storm-induced erosion expected to occur at the site (see Section 7.5, in Chapter 7 of this manual) must be determined before any assumptions about, or analyses of, the soils are made. Only those soils that will remain after erosion can be relied on to support the foundation members.

### 13.2.2 Soils

The soils on any site can vary between solid rock to loose sand. The foundation design will be based on soil assumptions derived from sources that include the following:

- soil borings
- a review of borings from nearby sites
- a test pit dug at or near one of the pilings or foundation corners
- information from the local office of the Natural Resource Conservation Service (formerly Soil Conservation Service) and Soil Surveys published for each county
- test piles

Designs are frequently prepared in which the bearing capacity of the soil is assumed and it is the builder's responsibility to verify that design assumption. In pile-supported structures, where the building support relies upon friction between the pile and soil, two important soil parameters must be known or determined:

- for cohesionless soils, the angle of internal friction
- for cohesive soils, the cohesion value in lb/ft<sup>2</sup>

The United States Department of Agriculture (USDA) has developed the Unified Soil Classification system, which categorizes and describes soil types (see Table 13.1). General engineering guidelines about the properties of these soil types are listed in Table 13.2.

**Table 13.1** Soil Type Definitions Based on USDA Unified Soil Classification System

Soil Type	Symbol	Description
Gravels	GW	Well-graded gravels and gravel mixtures
	GP	Poorly graded gravel-sand-silt mixtures
	GM	Silty gravels, gravel-sand-silt mixtures
	GC	Clayey gravels, gravel-sand-clay mixtures
Sands	SW	Well-graded sands and gravelly sands
	SP	Poorly graded sands and gravelly sands
	SM	Silty sands, poorly graded sand-silt mixtures
	SC	Clayey sands, poorly graded sand-clay mixtures
Fine-Grain Silt and Clays	ML	Inorganic silts and clayey silts
	CL	Inorganic clays of low to medium plasticity
	OL	Organic silts and organic silty clays of low plasticity
	MH	Inorganic silts, micaceous or fine sands or silts, elastic silts
	CH	Inorganic clays of high plasticity, fine clays
	OH	Organic clays of medium to high plasticity

**Table 13.2** Engineering Properties of Soil Types Classified by USDA

Soil Type	Symbol	Bearing Capacity (lb/ft <sup>2</sup> )	Cohesion (lb/ft <sup>2</sup> )	Angle of Internal Friction <sup>o</sup> $\phi$
Gravels	GW	2700 - 3000		38 - 46
	GP	2700 - 3000		38 - 46
	GM	2700 - 3000		38 - 46
	GC	2700 - 3000		38 - 46
Sands	SW – loose	800 - 1600		34 - 42
	SP – loose	800 - 1600		34 - 42
	SM - firm	1600 - 3500		28 - 40
	SC - firm	1600 - 3500		38 - 46
Fine-Grain Silt and Clays	CL - soft	600 - 1200	0 - 250	
	CH - soft	600 - 1200	250 - 500	
	CL – firm	1500 – 2500	500 - 1000	
	CH – firm	1500 – 2500	500 - 1000	
	CL – stiff	3000 – 4500	1000 – 2000	
	CH - stiff	3000 - 4500	2000 - 4000	

**NOTE**

Permafrost conditions (e.g., as in coastal areas of Alaska) are not addressed in this manual. “Permafrost” refers to subsoil that remains permanently frozen.

The soil bearing capacities listed in Table 13.2 are intended to provide a suggested range of values that can be used when other data are not available. However, soils can vary significantly in bearing capacity from one site to the next. **This manual recommends that a geotechnical engineer be consulted when any unusual or unknown soil condition is encountered.**

Slope stability is often difficult to predict unless there is a history of slope failures at or near the site, or unless soil borings taken at the site indicate that failures are possible. An experienced geotechnical engineer can predict from the steepness of the slope, the drainage of the site above the slope, the soil type, and the angle of internal friction of the soil whether slope failure is likely at a particular site. The International Building Code 2000, hereafter referred to as the IBC 2000 (ICC 2000a), provides some guidance on the placement of footings near slopes. Figure 13-6 shows what can happen to buildings placed near the location of a slope failure.

**Figure 13-6**  
Damage caused by slope failure.



### 13.2.3 Pile Foundations

Pile foundations are the most common type of coastal building foundation in V zones and should be used in coastal A zones where flood depths exceed about 4 feet (see Figure 13-7). The most common type of pile foundation is the elevated wood pile foundation, in which the tops of the piles extend above grade to about the level of the DFE. Horizontal framing girders connected to the tops of the piles form a platform on which the house is built. This section concentrates on the construction of an elevated wood pile foundation.



#### NOTE

See Chapter 12 for a discussion of pile capacities compared to the installation method.

**Figure 13-7**  
Typical wood-pile foundation.

Precautions must be taken in the handling and storage of pressure-preservative-treated round or square wood piles. They should not be dragged along the ground or dropped. They should be stored well-supported on skids so that there is air space beneath the piles and they are not in standing water. Additional direction and precautions for pile handling, storage, and construction are found in Section 13.2.6 of this manual and in Section M4-91 of the American Wood-Preservers' Association (AWPA) Standards (AWPA 1994).

A major consideration in the effectiveness of pile foundations is the method for inserting the piles into the ground, which can determine the pile load capacity. The best method is to use a pile driver, which uses leads to hold the pile in position while a single- or double-acting diesel- or air-powered hammer drives the pile into the ground.

The pile driver method, while cost-effective for a development with a number of houses being constructed at one time, can be expensive for a single building. The drop hammer method is a lower-cost alternative to the pile driver. A drop hammer consists of a heavy weight that is raised by a cable attached to a power-driven winch and then dropped onto the end of the pile.

It is common practice to estimate the ultimate capacity of a single pile on the basis of the driving resistance. Several formulas are available for making such estimates. However, the results are not always reliable and may over-predict or under-predict the capacity, so the formulas should be used with caution. One method for testing the recommended capacity developed from a formula is to load test at least one pile at each location of known soil variation.

One formula for determining pile capacity is shown as Formula 13.1, which is for drop hammer pile drivers. Formulas for other pile driver configurations are provided in *Foundation and Earth Structures Design*, U.S. Department of the Navy Manual 7.2 (USDN 1982).



Pile Driving Resistance  
for Drop Hammer Pile  
Drivers

### Formula 13.1 Pile Driving Resistance for Drop Hammer Piledrivers

$$Q_{all} = 2WH / (S + 1)$$

where:  $Q_{all}$  = allowable pile capacity in lb  
 $W$  = weight of the striking parts of the hammer in lb  
 $H$  = effective height of the fall in ft  
 $S$  = average net penetration, given as in per blow for the last 6 in of driving

The advantage of driving piles, compared to using the other methods discussed below, is that the driving operation forces the soil outward around the pile, densifying the soil and causing increased friction along the sides of the pile, which provides greater pile load resistance. A disadvantage of pile driving, particularly with light equipment, is that it allows the piles “to wander” away from their intended locations. The resulting variation in the final locations of the pile tops can complicate subsequent construction of floor beams and bracing. The problem is worsened by piles with considerable warp, nonuniform soil conditions, and material buried below the surface of the ground such as logs, gravel bars, and abandoned foundations. It is prudent to inquire about subsurface conditions at the site of a proposed structure before committing to the type of pile or the installation method. A thorough investigation of site conditions can help prevent costly installation errors.

The soils investigation should include determinations of the following:

- the type of foundations that have been installed in the area in the past
- the type of soil that might be expected, from past soil borings and soil surveys
- whether the proposed site has been used for any other purpose, which would indicate whether there are any buried materials on the site
- how the site may have been used in the past, from a search of land records for past ownership

A less desirable but frequently used method of inserting piles into sandy soil is “jetting.” Jetting involves forcing a high-pressure stream of water through a pipe advanced along the side of the pile. The water blows a hole in the sand into which the pile is continuously pushed or dropped until the required depth is reached. Unfortunately, jetting loosens the soil around the pile and the soil below the tip, resulting in a lower load capacity.

Holes for piles may be excavated by an auger if the soil is sufficiently clayey or silty. In addition, some sands may contain enough clay or silt to permit augering. This method can be used by itself or in conjunction with pile driving. If the hole is full-sized, the pile is dropped in and the void backfilled. Alternatively, an undersized hole can be excavated and a pile driven into it. When the soil conditions are appropriate, the hole will stay open long enough to drop or drive in a pile. In general, piles dropped or driven into augered holes may not have as much capacity as those driven without augering.

If precast concrete piles or steel piles are used, only a regular pile driver with leads and a single- or double-acting hammer should be used. For any pile driving, the building jurisdiction or the engineer-of-record will probably require that a driving log be kept for each pile. The log will show the number of inches per blow as the driving progresses—a factor used in determining the pile capacity, as shown in Formula 13.1. As noted in Section 12.4.3, the two primary determinants of pile capacity are the depth of embedment in the soil and the soil properties.

### 13.2.3.1 Diagonal Bracing of Piles

The building design may include diagonal bracing of the piles in one or both plan directions. Figure 13-8 illustrates diagonal wood bracing. Diagonal bracing strengthens and stiffens the pile foundation at the cost of greater exposure to wave and debris impact. For most pile spacings and heights, diagonal bracing is designed as a tension-only brace. This means that the brace is too slender to be stable in resisting a compressive force. In a tension-only bolted brace connection, there must be an end distance of 7 bolt



diameters in the brace (as illustrated in Figure 12-69, in Chapter 12) and a side distance of 4 bolt diameters in the pile. These clearances may be difficult to achieve if two adjacent braces end on the same side of a pile.

**Figure 13-8**  
Diagonal wood bracing in a  
wood-pile foundation.



With tension-only braces, the design intent can be met only when all of the following conditions are met:

- The horizontal floor beams or girders just above the diagonals must serve as stiff, strong, and stable compression struts that span between the pile tops. These members allow forces to the piles that are not diagonally braced in the direction of the force to be transmitted to a pile that is braced in that direction.
- Solid connections, usually achieved with bolts, must be provided that transmit forces from the brace to the pile or floor system
- Bracing members must have sufficient strength to resist failure in tension throughout their life. This life will be shortened if the connections or the bracing members corrode, split, twist, bend, or otherwise change in such a way that their structural integrity is compromised.

The placement of the lower bolted connection of the diagonal to the pile requires some judgment. If the connection is placed too high above grade, the pile length below the connection is unbraced and the overall bracing is less strong and stiff. If the connection is placed too close to grade, the bolt hole is more likely to be flooded or infested with termites. Because the bolt hole passes through the untreated part of the pile, flooding and subsequent decay or termite infestation will weaken the pile at a vulnerable location. The bolt hole should be treated with preservative as discussed in Section 13.2.8 of this manual and in Section M4-91 of the AWP Standards (AWPA 1994).

### 13.2.3.2 Knee Bracing of Piles

Knee braces can be effective in supporting the pile against the lateral forces of wind and water. Figure 13-9 illustrates knee bracing. Knee bracing increases the strength and stiffness of an elevated pile foundation by restraining rotation at the top of the pile and reducing the pile bending length. Knee bracing is not as stiff or as strong as diagonal bracing. Knee braces have an advantage over diagonal braces in that they present less obstruction to waves and debris. Knee braces are shorter than diagonal braces and are usually designed for both tension and compression loads.



**Figure 13-9**  
Knee bracing in a  
wood-pile foundation.

The entire load path into and through the knee brace must be designed with sufficient capacity. The girder or beam to which the knee brace is connected must have the bending strength to resist the axial force in the knee brace. The connections at each end of the knee brace must have sufficient capacity in both tension and compression.

### 13.2.3.3 Grade Beams in Pile Foundations

The pile foundation design may or may not include grade beams. When used, grade beams tie the piles together, usually in both horizontal directions. Grade beams are usually made of wood or reinforced concrete. Their exposure to ground contact and possible wave forces requires highly durable construction. Wood grade beams must be of treated wood and be field treated where cuts and bores are made. For concrete grade beams, the concrete mix design, cover thickness, and curing must optimize durability. In addition, in areas subject to erosion or scour, grade beams must be designed to be self-supporting. Durability of concrete and wood construction is discussed in Section 13.2.7.

In V zones, grade beams must be used only for lateral support of the piles. If a floor is poured so that it is attached to or is monolithic with the grade beams, the bottom of the grade beam becomes the bottom of lowest horizontal structural member, which, as noted in Chapter 6, Section 6.4.3.3, must be at or above the Base Flood Elevation in order for the structure to be in compliance with the NFIP regulations.

If grade beams are used with wood piles, it is important that the connection of the grade beam to the pile does not encourage water retention. The maximum bending moment in the piles occurs at the grade beams. Decay caused by water retention at that critical point in the piles would likely induce failure under high-wind or wave forces.

### 13.2.3.4 Wood-Pile-to-Wood-Girder Connections

Piles are often notched to provide a bearing surface for a girder. The notching should not remove more than 50 percent of the pile cross section. Section 12.5.9 describes the load calculation that must be performed at this connection to resist failure in shear. The designer can state just how much bearing is needed for sufficient bearing strength and acceptable eccentricity. The girder must be truly bearing on the surface to be effective. If the bolts are not placed low in the girder, it can shrink away from the bearing and the load will be carried in the bolts. Where the side and bottom of a girder are in contact with a notched pile, the wood of the pile at the notch is mostly untreated because the pressure preservative does not fully penetrate the wood. The surfaces of the pile exposed by notching should be treated with a field preservative.

The pile-to-girder connection may be subjected to large uplift forces in strong winds. The bolted connection must withstand these forces. The bottom bolt must be at least 4 bolt diameters from the bottom of the girder. The top bolt must be at least 7 bolt diameters from the top of the pile. The bolts should not be too widely spaced vertically across a sawn wood deep girder, as shrinkage will cause the girder to split between the bolts. A glue-laminated or parallel strand girder will be drier at installation and much less susceptible to this

problem. Bolted connections should always be installed with washers on both the head and threaded ends of the bolt.

Vertical lag bolt, spike, or nail connections into the top of a wood pile should be avoided. Such connections have no building-code-allowed capacity in withdrawal and a reduced capacity in shear. In addition, the penetration invites water intrusion and subsequent decay that would further weaken the connection. For connections made with spikes driven into the side grain of a member, the spikes should be driven into drilled guide holes so that the wood will not be split.

Exposed wood should be assumed to have a moisture content greater than 19 percent in coastal areas. There is evidence that fasteners embedded in treated wood or naturally durable wood with a moisture content of more than 19 percent are prone to corrosion, because of the treatment chemicals and the natural wood extractive. The IBC 2000 (ICC 2000a) requires that fasteners for pressure-preservative-treated wood be of hot-dipped galvanized steel, stainless steel, silicon bronze, or copper. The California Redwood Association recommends the use of hot-dip galvanized nails in redwood.

### 13.2.4 Masonry Foundation Construction

The combination of high winds and moist (sometimes salt-laden) air can have a damaging effect on masonry construction by forcing moisture into the smallest of cracks or openings in the masonry joints. The entry of moisture into reinforced masonry construction can lead to corrosion of the reinforcement and subsequent cracking and spalling of the masonry. Moisture resistance is highly influenced by the quality of the materials and the quality of the masonry construction at the site. Masonry material selection is discussed in Section 12.6, in Chapter 12 of this manual.

The quality of masonry construction depends on many considerations. Masonry units and packaged mortar and grout materials should be stored off the ground and covered. Mortar and grouts must be carefully batched and mixed. As the masonry units are placed, head and bed joints must be well mortared and tooled. Masonry work in progress must be well protected. Concave joints and V-joints provide the best moisture resistance.

Moisture penetration or retention must be carefully controlled where masonry construction adjoins other materials. As in any construction in the coastal building envelope, flashing at masonry must be continuous, durable, and of sufficient height and extent to impede the penetration of expected wind-driven precipitation. Because most residential buildings with masonry foundations have other materials (e.g., wood, concrete, steel, vinyl) attached to the foundation, allowance must be made for shrinkage of materials as they dry out



#### NOTE

For more information about protecting metal connectors from corrosion, refer to FEMA NFIP Technical Bulletin 8, *Corrosion Protection for Metal Connectors in Coastal Areas*, in Appendix H.



#### WARNING

Open masonry foundations in earthquake hazard areas require special reinforcement detailing and pier proportions to meet the requirement for increased ductility.



## WARNING

Figure 13-10 shows an open masonry foundation with only two rows of piers. It is unlikely that this foundation system could resist overturning caused by the forces described in Chapter 11.

and for differential movement between the materials. Expansion and contraction joints must be placed so that the materials can easily move against each other.

Masonry is used for piers, columns, and foundation walls. As explained in Chapter 6, the NFIP regulations require open foundations (e.g., piles, piers, posts, and columns) for buildings constructed in V zones. Buildings in A zones may be constructed on any foundation system. **However, because of the history of observed damage in coastal A zones, and the magnitude of the flood and wind forces that can occur in these areas, this manual recommends that only open foundation systems be constructed in coastal A zones.** Figure 13-10 shows an open masonry foundation.

**Figure 13-10**  
Open masonry foundation.



Reinforced masonry has much more strength and ductility for resisting large wind, water, and earthquake forces than does unreinforced masonry. **This manual also recommends that permanent masonry construction in and near coastal flood hazard areas (both A zones and V zones) be fully or partially reinforced and grouted solid regardless of the purpose of the construction and the design loads. Grout should be in conformance with**

**the requirements of the IBC 2000 (ICC 2000a).** Knockouts should be placed at the bottom of fully grouted cells to ensure that the grout completely fills the cells from top to bottom.

For concrete masonry units, choosing Type I “moisture controlled” units and keeping them dry in transit and on the job will minimize shrinkage cracking. Usually, for optimum crack control, Type S mortar should be used for belowgrade applications and Type N mortar used for above-grade applications. The IBC 2000 specifies grout proportions by volume for masonry construction.

### 13.2.5 Concrete Foundation Construction

Concrete foundation or superstructure elements in coastal construction will almost always require steel reinforcement. Figure 13-11 shows a concrete foundation, and Figure 13-12 shows a house being constructed with concrete. Completed cast-in-place exterior concrete elements should provide 1-1/2 inch or more of concrete cover over the reinforcing bars. This thickness of cover concrete serves to protect the reinforcing bars from corrosion. An epoxy coating is often used to protect the bars from corrosion. The bars are also protected by the natural alkalinity of the concrete. However, if salt water penetrates the cover concrete and reaches the reinforcing steel, the concrete alkalinity is reduced by the salt chloride and the steel can corrode if it is not otherwise protected. As the corrosion forms, it expands and cracks the concrete, allowing the additional entry of water and further corrosion. Eventually, the corrosion of the reinforcement and the cracking of the concrete weakens the concrete structural element, making it less able to resist loads caused by natural hazards.



**Figure 13-11**  
Concrete foundation.



#### NOTE

In areas not subject to earthquake hazards, breakaway walls below elevated buildings may be of unreinforced, ungrouted masonry construction.



#### NOTE

Section 7.7 of the ACI Building Code Requirements for Structural Concrete, ACI 318-95 (ACI 1995), specifies minimum amounts of concrete cover for various construction applications.

**Figure 13-12**  
Concrete house.



During placement, concrete will normally require vibration to eliminate air pockets and voids in the finished surface. The vibration must be sufficient to eliminate the air, but not separate the concrete or water from the mix.

To ensure durability and long life, it is especially important in coastal, salt-water-affected locations that concrete construction be carried out carefully in a fashion that promotes durability. Appendix J, in Volume III of this manual, describes the IBC 2000 requirements for more durable concrete mixes with lower water-cement ratios and higher compressive strengths (5,000 psi) to be used in a salt water environment. The IBC 2000 also requires that additional cover thickness be provided. Proper placement, consolidation, and curing is also essential for durable concrete. The concrete mix water-cement ratio required by the IBC 2000 or by the design should not be exceeded by the addition of water at the site.

It is likely that concrete will have to be pumped at many sites because of access limitations or elevation differences between the top of the forms and the concrete mix truck chute. Pumping concrete will require some minor changes in the mix so that the concrete will flow smoothly through the pump and hoses. Plasticizers should be used to make the mix pumpable; do not use water to improve the flow of the mix. Concrete suitable for pumping generally must have a slump of at least 2 inches and a maximum aggregate size of 33-40 percent of the pump pipeline diameter. Pumping will also increase the temperature of the concrete, thus changing the curing time and characteristics of the concrete (depending on the outdoor temperature).

Freeze protection may be needed, particularly for columns and slabs, if pouring is done in cold temperatures. Concrete placed in cold weather takes longer to cure, and the uncured concrete may freeze, which will adversely

affect its final strength. Methods of preventing concrete from freezing during curing include the following:

- heating adjacent soil before pouring on-grade concrete
- warming the mix ingredients before batching
- warming the concrete with heaters after pouring (avoid overheating)
- placing insulating blankets over and around the forms after pouring
- selecting a cement mix that will shorten curing time (e.g., hi-early)

Like masonry, concrete is used for piers, columns, and walls. However, the recommendation made in Section 13.2.4 of this manual regarding open foundations in coastal A zones applies to concrete foundations as well. In addition, because the environmental impact of salt-laden air and moisture make the damage potential significant for concrete, **this manual recommends that all concrete construction in and near coastal flood hazard areas (both V zones and A zones) be constructed with the more durable 5,000-psi minimum compressive strength concrete regardless of the purpose of the construction and the design loads.**



### 13.2.6 Wood Foundation Construction

All of the wood used in the foundation piles, girders, beams, and braces must be pressure-preservative-treated wood or, when allowed, naturally decay-resistant wood. Section 12.6 (in Chapter 12) and Appendix J discuss the selection of materials for these wood elements. Piles must be treated with waterborne arsenicals, creosote, or both. Girders and braces may be treated with waterborne arsenicals, pentachlorophenol, or creosote. Certain precautions apply to working with any of these treated wood products, and additional precautions apply for pentachlorophenol- and creosote-treated wood. Additional information is available from Consumer Information Sheets where the products are sold.

When working with all treated wood, avoid frequent or prolonged inhalation of the sawdust. When sawing and boring, wear goggles and a dust mask. Only treated wood that is visibly clean and free of surface residue should be used for patios, decks, and walkways. Before eating or drinking, wash all exposed skin areas thoroughly. If preservatives or sawdust accumulate on clothes, wash the clothes (separately from other household clothing) before wearing them again. Dispose of the cuttings by ordinary trash collection or burial. The cuttings should not be burned in open fires or in stoves, fireplaces, or residential boilers because toxic chemicals may be produced as part of the smoke and ashes. The cuttings may be burned only in commercial or industrial incinerators or boilers in accordance with state and Federal regulations.



Avoid frequent or prolonged skin contact with pentachlorophenol or creosote-treated wood; when handling it, wear long-sleeved shirts and long pants and use gloves impervious to the chemicals (e.g., vinyl-coated gloves).

Pentachlorophenol-pressure-treated wood should not be used in residential interiors except for laminated beams or for building components that are in ground contact and are subject to decay or insect infestation and where two coats of an appropriate sealer are applied. Sealers may be applied at the installation site. Urethane, shellac, latex epoxy enamel, and varnish are acceptable sealers.

Creosote-treated wood should not be used in residential interiors. Coal tar pitch and coal tar pitch emulsion are effective sealers for outdoor creosote-treated wood-block flooring. Urethane, epoxy, and shellac are acceptable sealers for all creosote-treated wood.

Wood foundations are being constructed in some parts of the country as part of a basement or crawlspace. These foundation elements have walls constructed with pressure-preservative-treated plywood and footings constructed with wide pressure-preservative-treated wood boards such as 2x10's or 2x12's. Because the NFIP regulations allow continuous foundation walls (with the required openings) in coastal A zones, continuous wood foundations might seem to be acceptable in these areas. However, because of the potential forces from waves less than 3 feet high (as discussed in Chapters 11 and 12), a wood foundation supported on a wood footing is not recommended in coastal A zones.



### 13.2.7 Foundation Material Durability

Ideally, all of the pile-and-beam foundation framing of a coastal building would be protected from rain by the overhead structure, even though all of the exposed materials should be resistant to decay and corrosion. In practice, the overhead structure includes both enclosed spaces (such as the main house) and outside decks. The spaces between the floor boards on an outside deck allow water to pass through and fall on the framing below. A worst case for potential rain and moisture penetration exists when less permeable decks collect water and channel it to fall as a stream onto framing below. In addition, wind driven rain and ocean spray will penetrate into many small spaces; protection of the wood in these spaces is important to long-term durability of the structure.

The durability of the exposed wood frame will be improved if it is detailed to shed water during wetting and to dry readily afterward. Decay will occur in those wetted locations where the moisture content of the exposed untreated interior core of treated wood elements remains above the fiber saturation point—about 30 percent. The moisture content of seasoned (S-DRY) 2x wood

when it arrives at the job site can be as high as 19 percent, but this moisture content is quickly reduced as the wood dries in the finished building. (The moisture content of the large members (i.e., greater than 3x) will be much more than 19 percent when they arrive at the job site, and it will take months to drop below 19 percent.)

The potential for deterioration is greatest at end grain surfaces. Water is most easily absorbed along the grain, allowing it to penetrate deep into the member where it does not readily dry. Figure 13-13 illustrates deterioration in the end of a post installed on a concrete base. This is a typical place for wood deterioration to occur. Even when the end grain is more exposed to drying, the absorptive nature of the end grain creates an exaggerated shrink/swell cycling, resulting in checks and splits, which in turn allow increased water penetration.



**Figure 13-13**  
Wood decay at the base of a post supported by concrete.

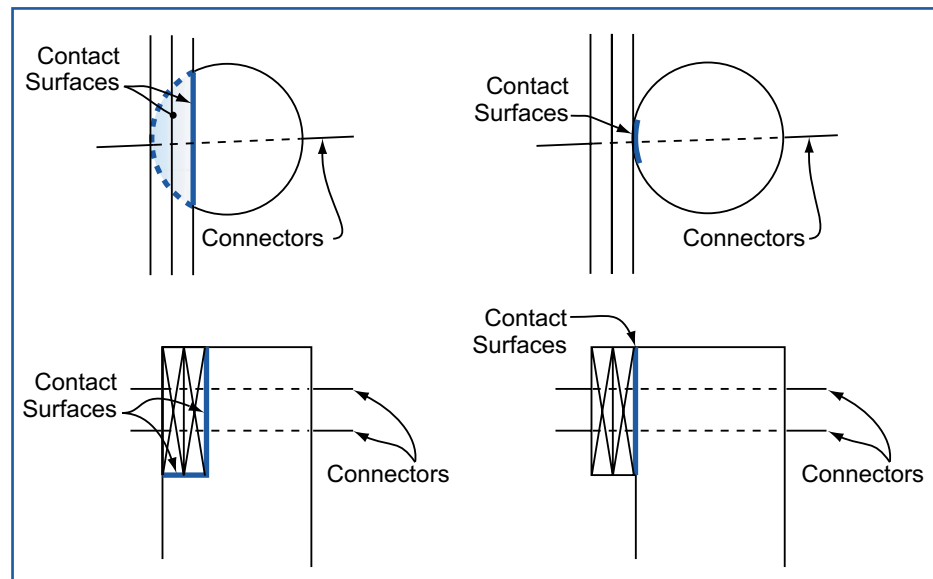
Exposed pile tops present the vulnerable horizontal end grain cut to the weather. Cutting the exposed top of a pile at a slant will not prevent decay, and may even channel water into checks. Water will enter checks and splits in the top and side surfaces of beams and girders. It can then penetrate into the untreated core and cause decay. These checks and splits occur naturally in large sawn timbers as the wood dries and shrinks over time. They are less common in glue-laminated timbers and built-up sections. It is generally, but not universally, agreed that caulking the checks and splits is unwise because caulking is likely to promote water retention more than keep water out. The best deterrent is to try to keep the water from reaching the checks and splits.

Framing construction that readily collects and retains moisture, such as pile tops, pile-beam connections, and horizontal girder and beam top surfaces, can be covered with flashing or plywood. However, there should always be an air gap between the protected wood and the flashing so that water vapor passing

out of the wood is not condensed at the wood surface. For example, a close-fitting cap of sheet metal on a pile top can cause water vapor coming out of the pile top to condense and cause decay. The cap can also funnel water into the end grain penetrations of the vertical fasteners.

When two flat wood surfaces are in contact in a connection, the contact surface will tend to retain any water directed to it. The wider the connection's least dimension, the longer the water will be retained, and the higher the likelihood of decay. Treated wood in this contact surface will be more resistant to decay, but only at an uncut surface. Make the least dimension of the contact surface as small as possible. When the contact surfaces are for structural bearing, provide only as much bearing surface as needed, considering both perpendicular-to-grain and parallel-to-grain bearing design stresses. For example, deck boards on 2x joists have a smaller contact surface least dimension than deck boards on 4x joists. A beam bolted alongside an unnotched round wood pile has a small least dimension of the contact surface. Figure 13-14 illustrates this least dimension concept.

**Figure 13-14**  
Minimizing the least dimension of wood contact surfaces.

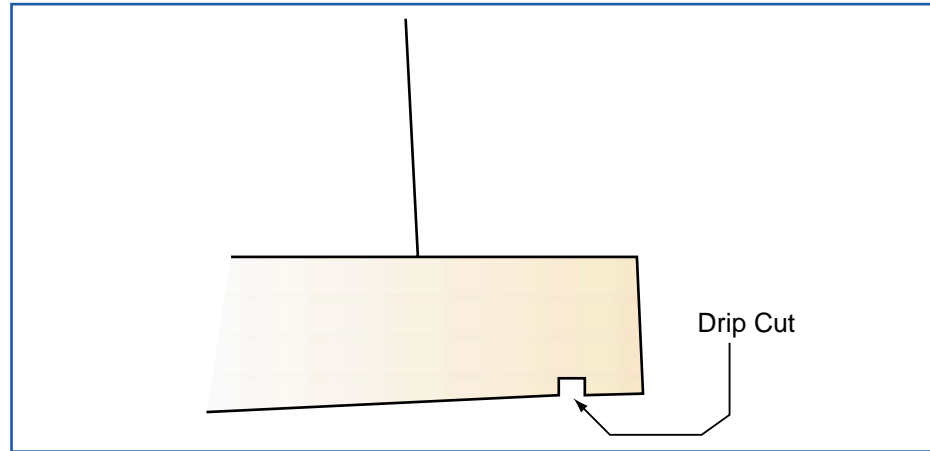


Poor durability performance has been observed in exposed “sistered” members. Where sistered members must be used in exposed conditions, they should be of ground-contact-rated treated wood and the top surface should be covered with a self-adhering modified bitumen (“peel and stick”) flashing membrane. This material is available in rolls as narrow as 3 inches wide. These membranes seal around nail penetrations to keep water out. In contrast, sheet-metal flashings over sistered members, when penetrated by nails, can channel water into the space between the members.

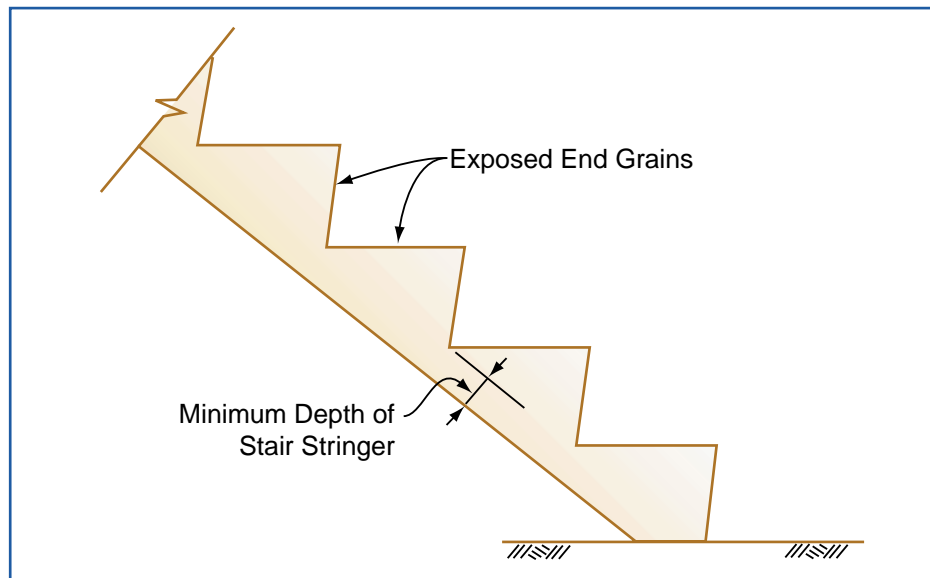
Other methods of improving exposed structural frame durability include the following:

- Use drip cuts to avoid horizontal water movement along the bottom surface of a member. Figure 13-15 shows this type of cut.
- Avoid assemblies that form “buckets” and retain water adjacent to wood.
- Avoid designs that result in ledges below a vertical or sloped surface. Ledges collect water quite readily, and the resulting ponding due to rain or condensation alternating with solar radiation will cause shrink-swell cycling, resulting in checks, which allow increased water penetration.
- To the extent possible, minimize the number of vertical holes in exposed horizontal surfaces from nails, lags, and bolts.
- Where possible, avoid the use of stair stringers that are notched for each stair. Notching exposes the end grain, which is then covered by the stair. As a result the stair will tend to retain moisture at the notch, right where the bending stress is greatest at the minimum depth section. Figure 13-16 illustrates this stair stringer exposure. Figure 13-17 shows the type of deterioration that can result.
- An alternative stair stringer installation is shown in Figure 13-18 where the stair treads are either nailed onto a cleat, or the stringer is routed out so the tread fits into the routed-out area. Even these alternatives allow water retention at end grain surfaces; therefore these surfaces should be field-treated with wood preservative.
- Caulk joints at wood connections to keep water out. Caulk only the top joints in the connection. Recaulk after the wood has shrunk (which can take up to a year for larger members).
- When structurally possible, consider using spacers or shims to separate contact surfaces. A space of about 1/16 inch will discourage water retention by capillary action, but can easily fill with dirt and debris. A 1/4-inch–1/2-inch space is sufficient to allow water and debris to clear from the interface. This spacing has structural limitations; a bolted connection with an unsupported shim will have much less shear capacity than an unspaced connection, because of increased bolt bending and unfavorable bearing stress distribution in the wood.

**Figure 13-15**  
Drip cut minimizes horizontal water movement along the bottom surface of a wood member.

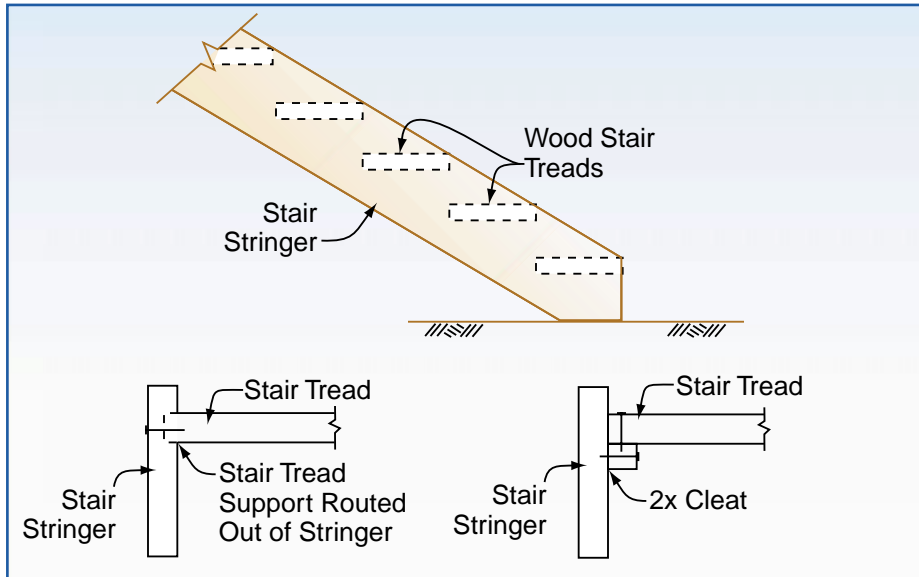


**Figure 13-16**  
Exposure of end grain in stair stringer cuts.



**Figure 13-17**  
Deterioration in a notched stair stringer.





**Figure 13-18**  
Alternative method of  
installing stair treads.

### 13.2.8 Field Preservative Treatment

Field cuts and bores of pressure-preservative-treated piles, timbers, and lumber are inevitable in coastal construction. Unfortunately, these cuts expose the inner untreated part of the wood member to possible decay and infestation. Although field preservative treatments are much less effective than pressure-preservative treatment, the decay and infestation potential can be minimized with treatment of the cuts and bolt holes with field-applied preservative. The AWWA standard *Care of Pressure-Treated Wood Products* (AWPA 1991) describes field treatment procedures and field cutting restrictions for poles, piles, and sawn lumber.

Field application of preservatives should always be done in accordance with instructions on the label. The most thorough application is by dip soaking for at least 3 minutes. When this is impractical, treatment may be done by thorough brushing or spraying. End grain is much more absorptive to field-applied preservatives than side grain. Bored holes should be poured full of *preservative*. If the hole passes through a check, then brushing of the hole will be necessary, because the preservative would otherwise run into the check instead of remaining in and saturating the hole.

The preservatives commonly used in pressure treating wood (waterborne arsenicals, pentachlorophenol, and creosote) are not acceptable for field application. Copper naphthenate is the most widely used field-applied preservative. Its deep green color may be objectionable, but wood treated with it can be painted with alkyd paints in dark colors after extended drying. Zinc naphthenate is less effective than copper naphthenate, especially in preventing insect infestation. It is clear and therefore can be used where the color of copper naphthenate is objectionable. It should not be painted with latex paints.

Tributyltin oxide (TBTO) is available, but should not be used in or near marine environments, because the leachates are toxic to aquatic organisms. Sodium borate is also available, but it does not readily penetrate dry wood, and it rapidly leaches out of wood when water is present; therefore, it is not recommended.



### NOTE

When substitutions are proposed, the designer's approval should be obtained before the substitution is made. The ramifications of the change must be evaluated, including the effects on the building components, constructability, and long-term durability. Code and regulatory ramifications must also be considered.

### 13.2.9 Substitutions

During construction, a contractor may find that materials called for in the construction plans or specifications are not available or that the delivery time for those materials will be too long and will delay the completion of the building. These conflicts will require that decisions be made about substituting one type of construction material for another. Because of the high natural hazard forces imposed on a building near the coast, and the effects of the severe year-round environment in coastal areas, some substitutions must be made only after approval by a design professional and, if necessary, the local building official.

### 13.2.10 The Top Foundation Issues for Builders

1. Piles, piers, or columns must be properly aligned.
2. The piles, piers, or columns must be driven or placed at the proper elevation to resist failure and must extend below the expected depth of scour and erosion.
3. Foundation materials must be flood damage-resistant (pressure treated wood, masonry, concrete).
4. Provide adequate support at the top of the foundation element to properly attach the floor framing system. Do not notch a wood foundation element more than 50 percent of its cross-sectional area.
5. Breakaway walls are intended to fail; do not overnail these walls to the foundations; do not install utilities or other obstructions behind these walls; do not finish inside these walls.
6. Where foundation elements are masonry or concrete (except slabs-on-grade), place the proper size of reinforcing, the proper number of steel bars, and provide the proper concrete cover over the steel.
7. Exposed steel in the foundation will corrode; plan for it by installing hot-dipped galvanized or stainless steel.
8. Areas of pressure-treated wood that have been cut or drilled will retain water and will decay; treat these cut areas in the field.

### 13.2.11 Inspection Points

There are many construction details in the foundation that, if not completed properly, can cause failure during a severe natural hazard event or cause premature failure because of deterioration caused by the harsh coastal environment. Improperly constructed foundations are frequently covered up, so any deficiency in the load-carrying or distributing capacity of one member will not easily be detected until failure occurs. It is therefore very important to inspect the foundation while construction is in progress to ensure that the design is completed as intended. Table 13.3 suggests critical inspection points for the foundation.

Inspection Point	Reason
1. Pile-to-girder connection	Ensure that pile is not overnotched, that it is field-treated, and that bolts are properly installed with washers and proper end and edge distance
2. Joist-to-girder connection	Verify presence of positive connection with properly nailed, corrosion-resistant connector
3. Joist blocking	Ensure that the bottom of the joist is prevented from bending/buckling
4. Sheathing nailing – number, spacing, depth	Sheathing must act as shear diaphragm
5. Material storage – protection from elements prior to installation	Ensure that the wood does not absorb too much moisture prior to installation – exposure promotes checks and splits in wood, warp and separation in plywood
6. Joist and beam material – excessive crown or lateral warping, large splits	Install new floors level and eliminate need to repair large splits in new material

**Table 13.3**  
Foundation Inspection Points



### WARNING

It is important to note that the connections described in this manual are designed to “hold” the building together in a “design event.” Builders who have not experienced such an event may underestimate the importance of installing connectors according to manufacturers’ recommendations. It is extremely important that connectors be installed properly.

## 13.3 Structural Frame

One of the most critical aspects of building in a coastal area is the method of connecting the structural members. A substantial difference usually exists between connections acceptable in inland construction and those required to withstand the natural hazard forces and environmental conditions in coastal areas. Construction in non-coastal, non-seismic areas usually must support only vertical dead and live loads and modest wind loads. In most coastal areas, large forces are applied by wind, velocity flooding, wave impact, and floating debris. The calculated forces along the complete load path usually require that the builder provide considerable lateral and uplift capacity in and between the roof, walls, floors, girders, and piles. Consequently, builders should be sure to use the specified connectors or approved substitutes.

Connectors that look alike may not have the same capacity, and a connector designed for gravity loads may have little uplift resistance.



The nails required for the connection hardware may not be regularly found on the job site. Full-diameter 8d to 20d short nails are commonly specified for specific hurricane/seismic connection hardware. To develop their full strength, these connections require that all of the holes in the hardware be nailed with the proper nails. In the aftermath of recent hurricanes, failed connector straps and other hardware were often found to have been attached with **too few nails, nails of insufficient diameter, or the wrong type of nail**. Figure 13-19 shows a connector that failed because of insufficient nailing.

**Figure 13-19**  
Hurricane Iniki (1992),  
Hawaii. Connector failure  
caused by insufficient  
nailing.



### WARNING

Proper nail selection and installation are critical. Contractors should not substitute different nails or nailing patterns without approval from the designer.



### NOTE

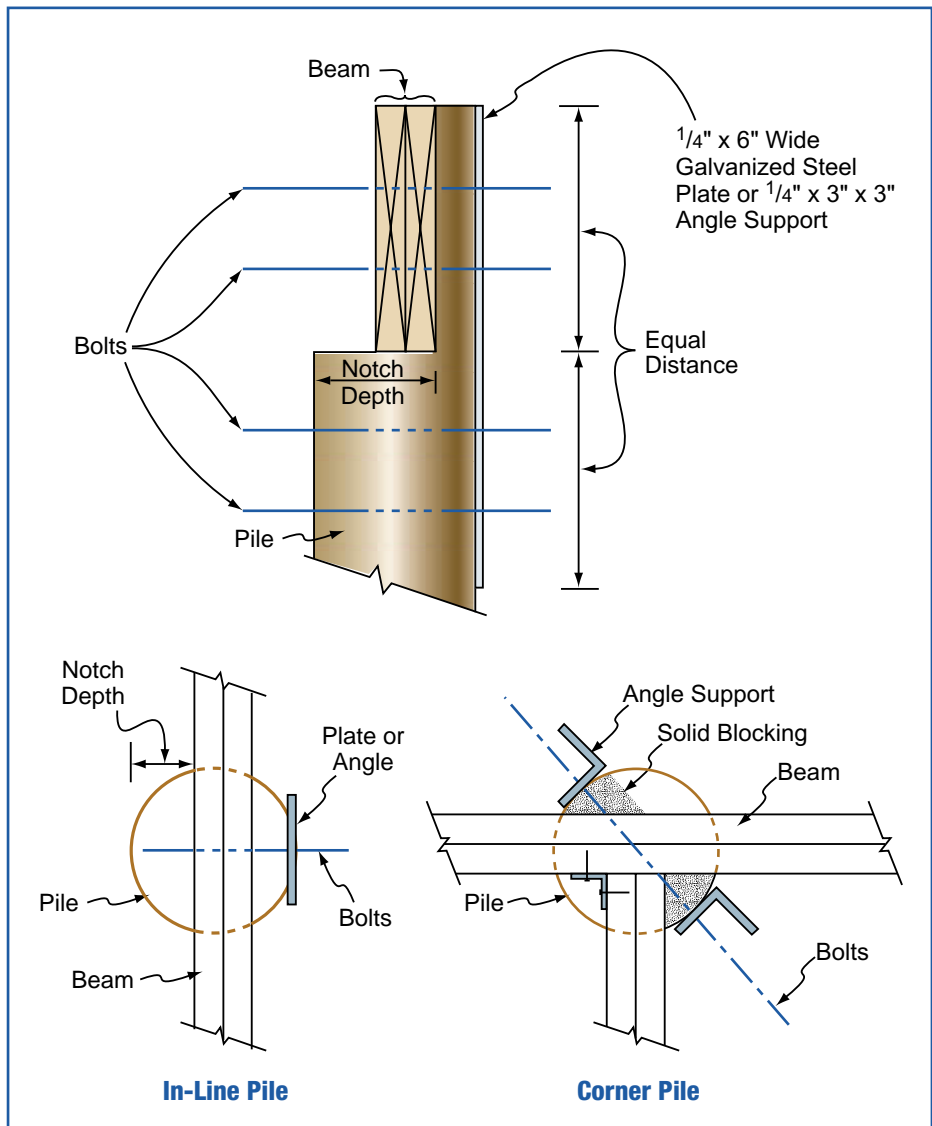
Additional information about pneumatic nail guns can be obtained from the International Staple, Nail and Tool Association, 512 West Burlington Ave., Suite 203, LaGrange, IL 60525-2245. A report prepared by National Evaluation Service, Inc., titled *Power-Driven Staples and Nails for Use in All Types of Building Construction* (NES 1997), presents information about the performance of pneumatic nail guns and includes prescriptive nailing schedules.

As mentioned previously, connection hardware must be corrosion-resistant. If galvanized connectors are used, additional care must be taken during nailing. When a hammer strikes the connector and the nail during installation, some of the galvanizing protection is knocked off. One way to avoid this problem is to use corrosion-resistant connectors that do not depend on a galvanized coating, such as stainless steel or wood (see Section 12.6.6, in Chapter 12 of this manual). Stainless steel nails should only be used with stainless steel connectors. An alternative to hand-nailing is to use one of the pneumatic hammers now available that “shoot” nails into connector holes.

All connections between members in a wood-frame building are made with nails, bolts, screws, or a similar fastener. Each of these fasteners is installed by hand. The predominant method of installing nails is by pneumatic nail gun. Many nail guns use nails commonly referred to as “sinkers.” Sinkers are slightly smaller in diameter and thus have lower withdrawal and shear capacities than those of the same size common nail. Nail penetration is governed by air pressure for pneumatic nailers, and this is an **important quality control issue** for builders. Many prescriptive codes have nailing schedules for various building elements such as shearwalls and diaphragms.

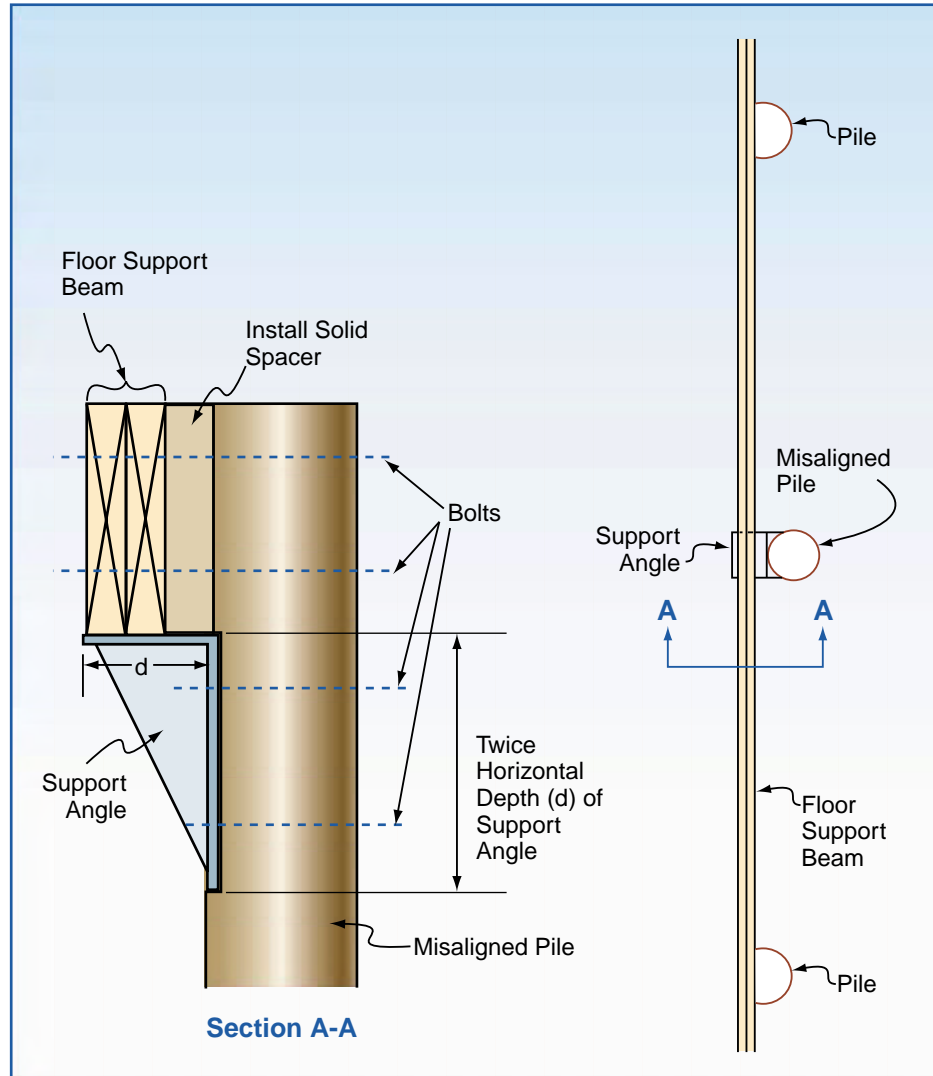
Toenailing should not be used to make a structural connection. Toenailing reduces the withdrawal capacity of the nails and frequently splits the wood, reducing the capacity even further.

Pile alignment and notching are critical not only to successful floor construction, but also to the structural adequacy during a natural hazard event. Construction problems related to these issues are also inevitable, so solutions to pile misalignment and overnotching must be developed. Figure 13-20 illustrates a method of reinforcing an overnotched pile, including one that is placed on a corner. The most appropriate solution to pile misalignment is to re-drive a pile in the correct location. An alternative is illustrated in Figure 13-21, which shows a method of supporting a beam at a pile that has been driven “outside the layout” of the pile foundation. Figure 13-22 illustrates proper pile notching for both two-member and four-member beams.

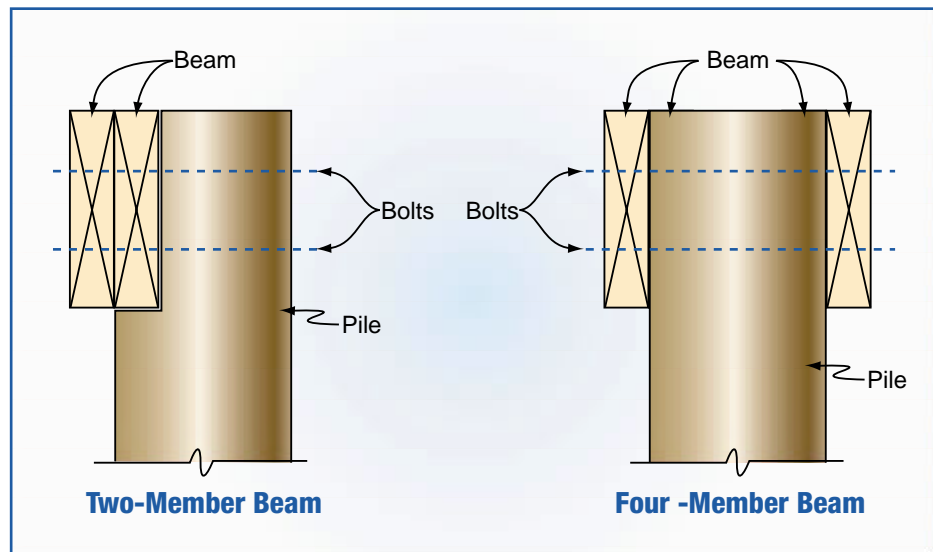


**Figure 13-20**  
Reinforcement of overnotched piles.

**Figure 13-21**  
Beam support at misaligned piles.



**Figure 13-22**  
Proper pile notching for two-member and four-member beams.



After the “square” foundation has been built, the primary layout concerns regarding how the building will perform under loads are confined to other building elements being properly located so that load transfer paths are complete.

### 13.3.1 Floor Framing

The connection between wood floor joists and the supporting beams and girders is usually a bearing connection for gravity forces with a twist strap tie for uplift forces. Figure 13-23 shows a twist tie connection. This connection is subjected to large uplift forces from high winds. In addition, the undersides of elevated structures, where these connectors are located, are particularly vulnerable to salt spray; the exposed surfaces are not washed by rain, and they stay damp longer because of their sheltered location. Consequently, the twist straps and the nails used to secure them must be hot-dipped galvanized or stainless steel. One way to reduce the corrosion potential for metal connectors located under the building is to cover the connectors with a plywood bottom attached to the undersides of the floor joists. (The bottom half of the joist-to-girder twist straps will still be exposed, however.) This covering will help keep insulation in the floor joist space as well as protect the metal connectors.

Because the undersides of V-zone buildings are exposed, the first floor is more vulnerable to uplift wind and wave forces, as well as to the lateral forces of moving water, wave impact, and floating debris. These loads cause compressive and lateral forces in the normally unbraced lower flange of the joist. Solid blocking or 1x3 cross-bridging at 8-foot centers is recommended for at least the first floor joists unless substantial sheathing (at least 1/2 inch thick) has been well-nailed to the bottom of these joists. Figure 13-23 also shows solid blocking between floor joists.



#### NOTE

See FEMA NFIP Technical Bulletin 8, *Corrosion Protection for Metal Connectors in Coastal Areas*, in Appendix H.

**Figure 13-23**  
Metal twist strap ties (circled). Also, note solid blocking between floor joists.

Floor framing materials other than 2x sawn lumber are becoming popular in many parts of the country. These materials include wood floor trusses and wood I-beams. Depending on the shape of the joist and the manufacturer, the proper installation of these materials may require some additional steps. For instance, some wood I-beams require solid blocking at the end of the joist where it is supported so that the plywood web does not crush. Figure 13-24 illustrates the use of plywood web I-beams as joists. As shown in the figure, the bottom flanges of the joists are braced with a small metal strip that helps keep the flange from twisting. Solid wood blocking is a corrosion-resistant alternative to the metal braces.

**Figure 13-24**  
Plywood web I-beams used as floor joists with metal brace used to keep the bottoms of the joists from twisting. Also note glue-laminated beam.



Floor surfaces in high-wind, flood, or seismic hazard areas are required to act as a diaphragm, as discussed in Chapter 12. For the builder, this means that the floor joists and sheathing are an important structural component. Therefore, the following installation features may require added attention:

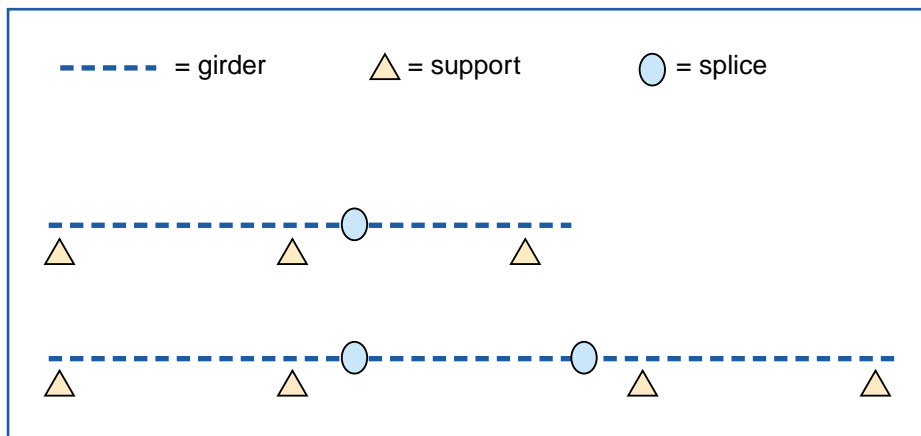
- Joints in the sheathing should fully bear on top of a joist, not a scabbed-on board used as floor support.
- Nailing must be done in accordance with a shear diaphragm plan.
- Construction adhesive is important for preventing “squeaky” floors, but the adhesive must not be relied upon for shear resistance in the floor.

Joints in the sheathing across the joists must be fully blocked with a full-joist-height block. (Horizontal floor diaphragms with lower shear capacities can be unblocked if tongue-and-groove sheathing is used.)

### 13.3.1.1 Horizontal Beams and Girders

As discussed in Appendix J, girders and beams can be solid sawn timbers, glue-laminated timbers (see Figure 13-24), or built-up sections. The girders span between the piles and support the beams and joists. The piles are usually notched to receive the girders. To meet the design intent, girders, beams, and joists must be square and level, girders must be secured to the piles, and beams and joists must be secured to the girders.

The layout process involves careful surveying, notching, sawing, and boring. The bottom of the notch provides the bearing surface for downward vertical loads. The bolted connection between the girder and the vertical notch surface provides capacity for uplift loads and stability. Girder splices are made as required at these connections. **Splices in multiple-member girders may be made away from the pile, but must be engineered so that the splices occur at points of zero bending moment.** This concept is illustrated in Figure 13-25.



**Figure 13-25**  
Acceptable locations for splices in multiple-member girders.

### 13.3.1.2 Substitution of Floor Framing Materials

The considerations discussed in Section 13.2.9 for substitution of foundation materials also apply to substitutions of floor framing materials.

### 13.3.1.3 Floor Framing Inspection Points

As a guide for floor framing inspections, Table 13.4 suggests critical inspection points.

**Table 13.4**  
Floor Framing Inspection  
Points

Inspection Point	Reason
1. Pile-to-girder connection	Ensure that pile is not overnotched, that it is field-treated, and that bolts are properly installed with washers and proper end and edge distance
2. Joist-to-girder connection	Verify presence of positive connection with properly nailed, corrosion-resistant connector
3. Joist blocking	Ensure that the bottom of the joist is prevented from bending/buckling
4. Sheathing nailing – number, spacing, depth	Sheathing must act as shear diaphragm
5. Material storage – protection from elements prior to installation	Ensure that the wood does not absorb too much moisture prior to installation – exposure promotes checks and splits in wood, warp and separation in plywood
6. Joist and beam material – excessive crown or lateral warping, large splits	Install new floors level and eliminate need to repair large splits in new material

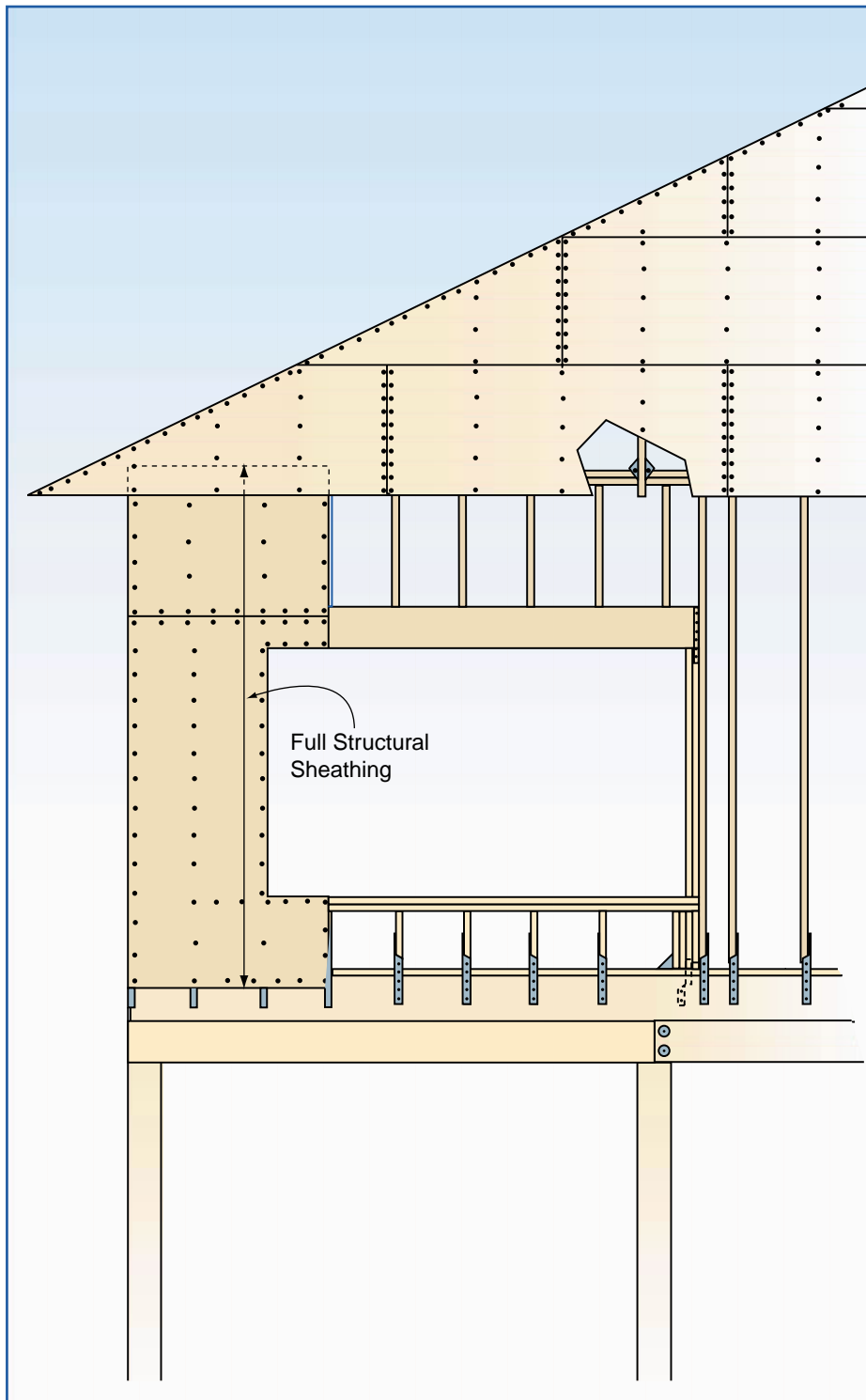
### 13.3.2 Wall Framing

The exterior walls and designated interior shear walls are an important part of the building's vertical and lateral force-resisting system. All exterior walls must withstand in-plane (i.e., parallel to the wall surface), gravity, and wind uplift tensile forces, and out-of-plane (i.e., normal or perpendicular to the wall surface) wind forces. Designated exterior and interior shear walls must withstand shear and overturning forces transferred through the walls to and from the adjacent roof and floor diaphragms and framing.

The framing of the walls must be of the specified material and must be fastened in accordance with the design drawings and standard code practice. Exterior wall and designated shear wall sheathing panels must be of the specified material and must be fastened with accurately placed nails whose size, spacing, and durability are in accordance with the design. Horizontal sheathing joints in shear walls must be solidly blocked. Shear transfer can be better accomplished if the sheathing extends the full height from the bottom of the floor joist to the top plate (see Figure 13-26), but sheathing this long is frequently not available.

The design drawings may show tiedown connections between large shearwall vertical posts and main girders. Especially in larger, taller buildings, these connections must resist thousands of pounds of overturning forces during high winds. See Section 12.4.2 for an example of the magnitude of these forces. The connections must be accomplished with careful layout, boring, and assembly. Shear transfer nailing at the top

plates and sills must be in accordance with the design. Proper nailing and attachment of the framing material around openings is very important. Section 12.4.2 also highlights the difficulty of transferring large shear loads when there are large openings in the shearwall.



**Figure 13-26**  
Using full-height sheathing  
improves transfer of shear.



It is very important that shearwall sheathing (e.g., plywood, OSB) with an exterior exposure be finished appropriately, with pigmented finishes such as paint (which last longer than unpigmented finishes) or semitransparent penetrating stains. It is also important that these finishes be properly maintained. Salt crystal buildup in surface checks in siding can cause damage to the siding. This damage is typically worse in siding that is sheltered from precipitation, because the salt crystals are made larger from salt spray but never washed off with fresh rainwater.

To meet the design intent, walls:

- must be plumb and square to each other and to the floor,
- must be lined up over solid support such as a beam, floor joists, or a perimeter band joist,
- must not have any more openings than designated by the plans,
- must not have openings located in places other than designated on the plans,
- must consist of material expected to resist corrosion and deterioration, and
- must be properly attached to the floors above and below the wall, including holddown brackets required to transfer overturning forces.

In addition, all portions of walls designed as shearwalls must be covered with sheathing nailed in accordance with either the plans or a specified prescriptive standard.

### **13.3.2.1 Interior Steel Frames**

In coastal buildings with large openings or cathedral ceilings, the design may include steel moment-resisting frames for wind and/or seismic lateral forces. These frames are necessary when even double-sheathed plywood walls have insufficient capacity. Figure 12-49, in Chapter 12, shows a steel moment frame installed in the wall of a coastal residential building.

The fabrication of steel moment frames will usually be done by a steel specialty subcontractor, who will first prepare a set of shop drawings from the design drawings. The contractor and designer should both check the accuracy of the shop drawings. Most frames will have to be transported in sections and assembled on site with field bolting and/or welding. The building code or designer may require special inspection or shop certification for the shop and field frame welding. If the frame is not exposed, a finish of shop primer will be adequate. Exposed parts of the frame will require hot-dip galvanizing or some other finish suitable for exterior exposure.

Alignment of the frame in the building will be critical. It is also important that the connections that transfer forces to the frame be properly accomplished so that the frame can effectively brace the structure. These steel-to-wood connections are usually made with bolts, threaded rod welded to the steel for connecting to the wood, or with powder-actuated fasteners “shot” into the steel. The ability of these powder-actuated devices to transfer the shear and tension forces must be verified (and certified) by the supplier.

### 13.3.2.2 Substitution of Wall Framing Materials

The considerations discussed in Section 13.2.9 for substitution of foundation materials also apply to substitutions of wall framing materials.

### 13.3.2.3 Wall Framing Inspection Points

As a guide for wall framing inspections, Table 13.5 suggests critical inspection points.

Inspection Point	Reason
1. Wall framing attachment to floors	Ensure that nails used are of sufficient size, type, and number
2. Size and location of openings	Critical to performance of shear wall
3. Wall stud blocking	Ensure that there is support for edges of sheathing material
4. Sheathing nailing – number, spacing, depth of nails	Sheathing must act as shear diaphragm
5. Material storage – protection from elements prior to installation	Ensure that the wood does not absorb too much moisture prior to installation (Exposure promotes checks and splits in wood, warp and separation in plywood.)
6. Stud material – excessive crown (crook) or lateral warping (bow)	Maintain plumb walls and eliminate eccentricities in vertical loading
7. Header support over openings	Ensure that vertical and lateral loads will be transferred along the continuous load path

**Table 13.5**  
Wall Inspection Points

### 13.3.3 Roof Framing

Proper roof construction is very important in high-wind and earthquake hazard areas. Reviews of wind damage to coastal buildings reveal that most damage starts with the failure of roof elements. The structural integrity of the roof depends on a complete load path, including the resistance to uplift of porch and roof overhangs, gable end overhangs, roof sheathing nailing, roof framing nailing and strapping, roof member-to-wall strapping, and gable end-wall bracing.

All of this construction must be done with the specified wood materials, straps, and nails. The appropriate nails must be used in all of the holes in the straps so that the straps will develop their full strength. Sheathing nails must be of the specified length, diameter, and head, and the sheathing must be nailed at the correct spacing. In addition, sheathing nails must penetrate the underlying roof framing members and **must not be overdriven**, which frequently occurs when pneumatic nail guns are used. When prefabricated roof trusses are used, handling precautions must be observed, and the trusses must be laterally braced as specified by the designer or manufacturer.

---

## IMPORTANT

The most common roof structure failure is the uplift failure of porch, eave, and gable end overhangs. The next most common is roof sheathing “peeling” away from the framing. The nailing of the sheathing at the leading edge of the roof, the gable edge, and the joints at the hip rafter or ridge are all very important, as is securing the roof framing to prevent uplift. This failure point is also the most likely place that progressive failure of the entire structure could begin.

---

Field investigations indicate failure of houses with wood-framed roofs occurs first at the roof, often at improper fastening between the roof sheathing and building frame. Figure 13-27 shows an example of what happened to plywood roof sheathing during Hurricane Andrew when fasteners had not been properly embedded into the top chord of the roof truss. This potential failure mode persists in new housing; Figure 13-28 shows nails that missed the roof rafters on a house being constructed in 1998.

**Figure 13-27**

Hurricane Andrew (1992), Florida. Roof sheathing found in debris. Staples were off-line and therefore not connected to top chord of supporting truss. Note light area on the underside of sheathing (highlighted) where top chord of truss was in contact with sheathing.

**Figure 13-28**

Sheathing nails (circled) missed roof rafter in new construction.

To meet the design intent, roofs must meet the following requirements:

- Roof trusses and rafters must be properly attached to the walls.
- Roof sheathing must be nailed according to either the construction plans or a specified prescriptive standard.
- Roofs must consist of materials expected to resist corrosion and deterioration, particularly the connectors.

### 13.3.3.1 Substitution of Roof Framing Materials

The considerations discussed in Section 13.2.9 for substitution of foundation materials also apply to substitutions of roof framing materials.

### 13.3.3.2 Roof Frame Inspection Points

As a guide for roof framing inspections, Table 13.6 suggests critical inspection points.

**Table 13.6**  
Roof Frame Inspection Points

Inspection Point	Reason
1. Roof framing attachment to walls	Ensure that sufficient number, size, and type of nails is used in the proper connector
2. Size and location of openings	Critical to performance of roof as a diaphragm
3. "H" clips or roof frame blocking	Ensure that there is support for edges of the sheathing material
4. Sheathing nailing – number, spacing, depth of nails	Sheathing must act as shear diaphragm and resist uplift
5. Material storage – protection from elements prior to installation	Ensure that the wood does not absorb too much moisture prior to installation (Exposure promotes checks and splits in wood, warp and separation in plywood.)
6. Rafter or ceiling joist material – excessive crown or lateral warping	Maintain level ceiling
7. Gable-end bracing	Ensure that bracing conforms to design requirements and specifications

### 13.3.4 The Top Structural Frame Issues for Builders

1. Connections between structural elements (roofs to walls, etc.) must be made so that the full natural hazard forces are transferred along a continuous load path.
2. Carefully nail components so that the nails are fully embedded.
3. Comply with manufacturers recommendations on hardware use and load ratings.
4. Use only material rated and specified for the expected use and environmental conditions.
5. The weakest connections will fail first; the concept of continuous load path must be considered for every connection in the structure. It will be important to pay particular attention to these connections.
6. Exposed steel in the structural frame will corrode, even in places such as the attic space. Plan for it by installing hot-dipped galvanized or stainless steel hardware and nails.
7. Compliance with suggested nailing schedules for roof, wall, and floor sheathing is very important.



#### **WARNING**

Do not substitute nails, fasteners, or connectors without approval of the designer.

## 13.4 Building Envelope

The building envelope comprises the roof covering, exterior wall covering, and exterior doors and windows. The floor is also considered a part of the envelope for buildings elevated on open foundations. The keys to successful building envelope construction include the following:

- A suitable design must be provided that is sufficiently specified and detailed to allow the contractor to understand the design intent and to give the contractor adequate and clear guidance.

Lack of sufficient and clear design guidance regarding the building envelope is common. In this situation, the contractor should seek additional guidance from the designer or be responsible for providing design services in addition to constructing the building.

- The building must be constructed as intended by the designer (i.e., the contractor must follow the drawings and specifications).

Examples include installing flashings, building paper, or air infiltration barriers so that water is shed at laps; using the specified type and size of fasteners and spacing them as specified; eliminating dissimilar metal contact; using materials that are compatible with one another; installing components in a manner that accommodates thermal movements so that buckling or jacking out of fasteners is avoided; applying finishes to adequately cleaned, dried, and prepared substrates; installing backer rods or bond breaker tape at sealant joints; and tooling sealant joints.

- For products/systems specified by performance criteria, the contractor must exercise care in selecting those products/systems and in integrating them into the building envelope.

For example, if the designer specifies a window by requiring that it be capable of resisting a specified wind pressure, the contractor should ensure that the type of window that is being considered can resist the pressure when tested in accordance with the specified test (or a suitable test if a test method is not specified). Furthermore, the contractor needs to ensure that the manufacturer, designer, or other qualified entity provides guidance on how to attach the window frame to the wall so that the frame will resist the design pressures.

- When the selection of accessory items is left to the discretion of the contractor, without prescriptive or performance guidance, the contractor must be aware of and consider special conditions at the site (e.g., termites, unusually severe corrosion, high earthquake or wind loads) that should influence the selection of the accessory items.

For example, instead of using screws in plastic sleeves to anchor components to a concrete or masonry wall, a contractor can use metal

expansion sleeves or steel spikes intended for anchoring to concrete, which should provide a stronger and more reliable connection. Or, the use of plastic shims at metal doors may be appropriate to avoid termite attack.

- Proposed substitutions of materials must be thoroughly evaluated and must be approved by the designer (see Section 13.2.9).

The building envelope must be installed in a manner that will not compromise the building's structural integrity. For example, during construction, if a window larger than originally intended is to be installed because of delivery problems or other reasons, the contractor should obtain the designer's approval prior to installation. The larger window may unacceptably reduce the shear capacity of the wall, or different header or framing connection details may be necessary. Likewise, if a door is to be located in a different position, the designer should evaluate the change to determine whether it adversely affects the structure.

- Adequate quality control (i.e., inspection by the contractor's personnel) and adequate quality assurance (i.e., inspection by third parties such as the building official, the designer, or a test lab) must be provided.

The amount of quality control/quality assurance will depend on the magnitude of the natural hazards being designed for, complexities of the building design, and the type of products/systems being used. For example, installation of windows that are very tall and wide and make up the majority of a wall deserves more inspection than isolated, relatively small windows. Inspection of roof coverings and windows is generally more critical than inspection of most wall coverings, because of the general susceptibility of roofing and glazing to wind and the resulting damage from water infiltration that commonly occurs when these elements fail.

### **13.4.1 Substitution of Building Envelope Materials**

The considerations discussed in Section 13.2.9 for substitution of foundation materials also apply to substitutions of envelope materials.

### **13.4.2 Building Envelope Inspection Points**

As a guide for building envelope inspections, Table 13.7 suggests critical inspection points.

Inspection Point	Reason
1. Siding attachment to wall framing	Ensure there are sufficient number, type, and spacing of nails
2. Attachment of windows and doors to the wall framing	Ensure there are sufficient number, type, and spacing of either nails or screws
3. Flashings around wall and roof openings, roof perimeters, and at changes in building shape	Prevent water penetration into building envelope
4. Roof covering attachment to sheathing, including special connection details	Minimize potential for wind blowoff (In high-seismic-load areas, attention to attachment of heavy roof coverings, such as tile, is needed to avoid displacement of the covering.)
5. Attachments of vents and fans at roofs and walls	Reduce chance that vents or fans will blow off and allow wind-driven rain into the building

**Table 13.7**  
Building Envelope Inspection Points

### 13.4.3 The Top Building Envelope Issues for Builders

1. Many manufacturers do not rate their products in a way such that it is easy to determine if the product will really be adequate for the coastal environment and the expected loads. Require suppliers to provide information about product reliability in this environment.
2. Wind-driven rain will find a way into the house if there is a path left open. Sealing openings and shedding water will play a significant part in building a successful coastal home.
3. Window and door products are particularly vulnerable to wind-driven rain leakage and air infiltration. These products should be tested and rated for the expected coastal conditions.
4. Use the current high-wind techniques of extra roof surface sealing or attachment at the eaves and gable end edges.
5. Coastal buildings do require more maintenance than inland structures. This maintenance requirement needs to be considered in the selection of materials and the care with which they are installed.





## WARNING

Cantilever decks should not be placed over bulkheads or retaining walls where wave runoff on the vertical structure could damage the deck.

## 13.5 Appurtenant Structures

### 13.5.1 Decks

Decks often form a significant area of the elevated building platform. They are usually of 2x material, spaced to allow water drainage. The material choices, discussed in detail in Appendix J, include pressure-preservative-treated wood, naturally durable wood, and wood-plastic composites. The deck boards should be placed with a 1/8-inch–1/4-inch spacing to allow for drainage and possible expansion when wetted. This gap is especially needed at the end grain. Many builders fasten deck boards with screws or ring-shank nails to minimize nail pops.

The question of whether to place flat-grained deck boards heart side up (rings concave up) or bark side up (rings concave down) has been a subject of continued debate for years. Both orientations have advantages and disadvantages. Wood will naturally shrink to be concave on the bark side. Treated southern pine lumber from small trees will tend to have more treatment on the bark (sapwood) side. Shakes (cracks along the growth rings) tend to form on the heart side. So a deck board with the heart side up will more likely dry with a convex top surface that sheds water, but it will be prone to having shakes on the top surface. With the bark side up, the board will more likely dry with a concave top surface that holds water, but the exposed surface will be the treated sapwood that will resist the retained water. For minimum warp, select the more costly vertical-grained lumber over flat-grained lumber. Choose dried wood over green, or use green wood with less tendency to warp. Green heart redwood and cedar are less prone to warp than green Douglas fir.

Wood railings around decks must be carefully designed for both strength and durability. The IBC 2000 (ICC 2000a) requires that handrails resist a horizontal distributed load of 20 lb/ft and a nonconcurrent point load of 200 lb. The designer and builder must achieve this capacity in the wood railing construction and the associated connections while considering stress reductions required by the code for wet use and ripped lumber. The completed railing construction should not retain water in its connections that will lead to decay. Open railing systems are preferable to solid railings because of the increased wind load induced on solid railings. Also, open railings below the DFE allow for improved flow-through of flood waters. The local building code will specify the maximum allowable size of the openings between the railings.

Post-storm investigations of building damage have provided substantial evidence that decks and other exterior structures create a significant amount of debris when they break apart under the forces of wind and water. It is important that the construction methods and materials used in the installation of these exterior structures meet the same requirements as those established

for the primary building, because the failure modes are the same and the load mechanisms are the same. Indeed, sometimes the loads on appurtenant structures are even higher because of their exposure. In considering the potential loads on decks, the builder should keep in mind that many decks become screened-in porches with roofs and thus, in the event of high winds, experience even greater loads. Decks can be built to withstand severe events, as shown by Figure 13-29, a photograph of a deck that survived when the building did not.

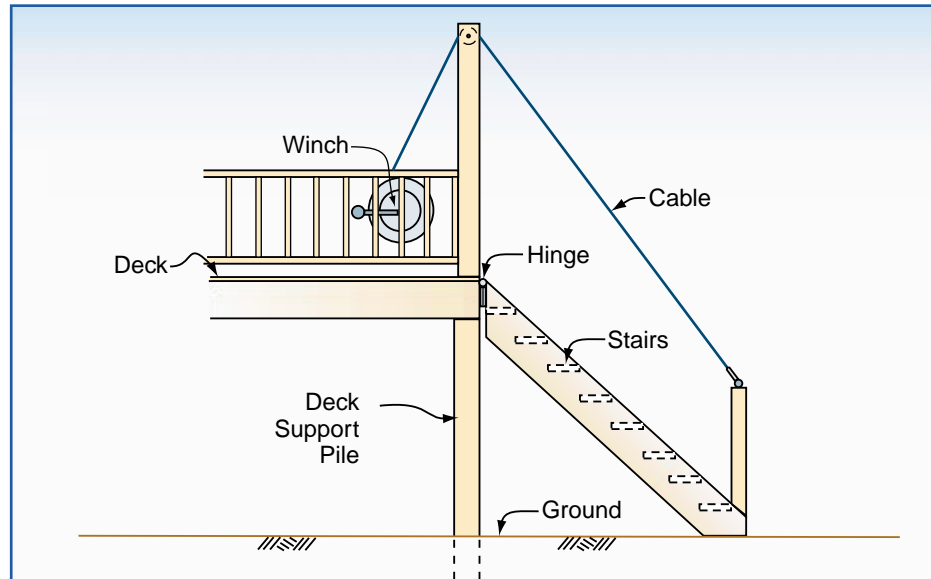


**Figure 13-29**  
Building damage from Hurricane Opal at Pensacola Beach, Florida. The deck, which was constructed to State of Florida Coastal Construction Control Line (CCCL) design requirements, survived; the building, which was not constructed to CCCL requirements, did not survive. See Appendix G for a discussion of the Florida CCCL.

Stairs leading from decks are frequently a source of storm-created debris. Stairs should have open risers and should be supported on posts or piles embedded below the expected depth of storm-induced scour if they are expected to survive a severe storm. Debris from stairs is minimized when the stairs are located on the landward side of the building rather than the seaward side.

An alternative is to connect the stairs to the deck in such a way that the stairs can be removed or elevated above the expected flood depth. Frequently, such a design involves the use of winches and cables so that the stairs can be elevated by a person on the deck level. In order for the stair section to be lifted, the stair/deck connection must be hinged. Figure 13-30 illustrates this stair elevation technique. Note that this system cannot be used for stairs that provide the only means of egress and access for the building.

**Figure 13-30**  
Stair elevation system. Note that this system cannot be used for stairs that provide the only means of egress and access for the building.



### 13.5.2 Storage Buildings

Storage buildings and any other building installed away from the primary building should be anchored so that they will not be susceptible to overturning or sliding into another building and causing collateral damage. Storage buildings will be exposed to similar loads as the main structure and can fail in the same way. The most significant problem is that the storage building can become debris and cause more severe damage and loss to adjacent buildings.

An effective way to reduce damage from the failure of storage buildings and other small buildings is to not install these buildings in coastal areas. If the building is considered sacrificial, it should be pointed out to the homeowner and neighbors that the sacrifice may cause significant damage to either the primary or adjacent structures.

### 13.5.3 Swimming Pools and Hot Tubs

Pools and hot tubs are normally made of one of the following:

- reinforced concrete
- fiberglass
- reinforced masonry

For one-piece units, such as those made of fiberglass, the installer will frequently use a crane to set the pool, so the building site will need to be accessible for this large piece of equipment. Locations for pumps, piping, a

heater (if there is one), fuel supply, and other associated equipment must be found so that the following requirements are met:

- The equipment must be located in the proper place to supply the pool with water.
- The equipment must be elevated to or above the DFE so that the potential for flood damage is minimized.
- The equipment must be set so that wind, or seismic, and water forces (including inundation by salt water or sediment) will not displace or damage it. Unless specifically designed, most mechanical equipment is not intended to be inundated with salt water. Equipment installed in the corrosive coastal environment will normally require corrosion-resistant piping (usually PVC), stainless steel pump impellers, cast iron pump bodies, and totally enclosed electrical components.

The design considerations for one-piece pools are covered in Section 12.9.4 in Chapter 12. The builder, however, must be able to execute the design intent, which includes the following:

- A one-piece pool must be able to resist flood forces with minimal damage, whether the pool is full or empty. This means that an in-ground pool must resist failure from buoyancy as well as wall fracture.
- The pool equipment must be easily returned to service after a severe event. A flexible connection between the pump and piping may help achieve this objective so the equipment can move under forces from the severe event. This coupling will also reduce stress on the pipe from vibration.
- Pool accessories (e.g., cleaning nets, lane dividers) can become airborne debris and should have a secure storage location.

The design intent for concrete pools includes the following:

- Elevation of an in-ground pool should be such that scour will not permit the pool to fail from either normal internal loads of the filled pool or from exterior loads imposed by the flood forces.
- The pool should be located as far landward as possible and should be oriented in such a way that flood forces are minimized. This includes placing the pool with the narrowest dimension facing the direction of flow, orienting the pool so there is little to no angle of attack from flood water, and installing a pool with rounded instead of square corners. All of these design choices will reduce the amount of scour around the pool and thereby improve the chances the pool will survive the storm. These concepts are illustrated in Figure 13-31.



### NOTE

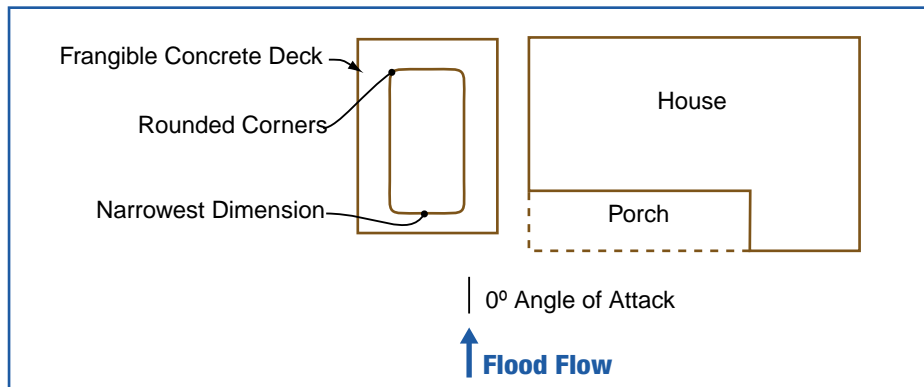
Two articles concerning swimming pool design standards in V zones are included in Appendix L. The articles—*Scour Impact of Coastal Swimming Pools on Beach Systems* and *Conceptual Breakaway Swimming Pool Design for Coastal Areas*—report the results of studies funded by FEMA.



### CROSS-REFERENCE

See Section 12.9.4, in Chapter 12, for design guidance and regulatory requirements regarding swimming pools.

**Figure 13-31**  
Recommendations for  
orientation of in-ground pools.



- A concrete pool “deck” should be frangible, so that flood forces will create concrete fragments that will help reduce scour. The concrete deck should be installed with no reinforcing and should have contraction joints placed at 4-foot squares to “encourage” failure. See Figure 12-121, in Chapter 12, for details on constructing a frangible concrete pad.
- Pools should not be installed on fill in or near a V zone. Otherwise, a pool failure may result from scour of the fill material

### 13.5.4 Walkways and Sidewalks

Walkways and sidewalks built adjacent to a coastal building will normally require permits from the local building official, and local regulations will usually require that these structures be shown on the plans. Walkways built over a dune or on, around, or over an erosion control structure will probably require a building permit from the state agency responsible for dune and beach protection, regardless of whether the walkway is for private or public beach access.

Walkways and sidewalks are usually built of concrete or wood. Concrete will normally be restricted to “flat” work or sidewalks, parking pads, and similar features. As recommended in other sections of this manual, this concrete should be installed with no reinforcing steel and it should have contraction joints at 4-foot squares so that it can be easily broken into 4-foot x 4-foot sections when subjected to flood forces.

Wood walkway members in ground contact should be ground-contact-rated pressure-preservative-treated wood. Wood walkway members not in ground contact should be aboveground-rated (or better) pressure-preservative-treated wood or naturally decay-resistant wood. The environmental conditions at or near the coast will be particularly hard on such walkways: salt air, rain, sun, and sand will work to alternately dry out, wet, and abrade

the wood. Wood walkways at grade level should be anchored with posts buried several feet in the ground to prevent uplift from wind. During a severe flood event, scour may occur at the edges of the walkway and cause an uplift failure, so the posts should be buried a minimum of 8 feet below the expected level of scour (see Appendix I).

There are several state-initiated guidance documents on walkway/walkover construction. Appendix I includes a construction guidance document from the State of Florida, Bureau of Beaches and Coastal Systems, *Beach/Dune Walkover Guidelines* (January 1998) and a document from Florida Sea Grant titled *Beach Dune Walkover Structures* (December 1983).

## 13.6 Utility/Mechanical Equipment

This section presents guidance concerning the installation of elevators, building utility systems (heating, ventilating, and cooling [HVAC], electrical, water, and wastewater), and storage tanks. For detailed information about the design and construction of utility systems for buildings in flood hazard areas, refer to *Protecting Building Utilities From Flood Damage – Principles and Practices for the Design and Construction of Flood Resistant Building Utility Systems*, FEMA 348 (FEMA 1999).

### 13.6.1 Elevators

Elevators are becoming commonplace in many coastal homes. Normally, these elevators have only a one- to four-person capacity, and they almost always require installation in an area that will at least be partially below the DFE. To minimize flood damage to the elevator and its parts, the builder should look for locations above the DFE to mount elevator equipment (e.g., electrical controls, hydraulic pumps).

Normally, for fire safety reasons, elevators are equipped with a default device that sends the cab to the lowest floor when there is a power outage (which will always occur during a major storm). For the protection of the elevator equipment and the occupants, this manual recommends that a float switch be installed that activates when inundated by flood water and sends the elevator cab to a floor above the DFE. For additional information, see FEMA NFIP Technical Bulletin 4, *Elevator Installation for Buildings Located in Special Flood Hazard Areas*, in Appendix H.



#### NOTE

For additional information about the proper design and construction of utility system components for buildings in flood hazard areas, refer to *Protecting Building Utilities From Flood Damage – Principles and Practices for the Design and Construction of Flood Resistant Building Utility Systems*, FEMA 348 (FEMA 1999).

### 13.6.2 Heating, Ventilating, and Cooling (HVAC) Systems

HVAC systems include a number of components that must be installed so that they are protected from damage during a severe wind, flood, or seismic event. These components include the following:

- outdoor condensers
- air-handling units
- ductwork for supply and return air
- electrical components for power to the air-handlers and controls
- fuel storage (if not electric)

If the HVAC components inside the building are all installed above the DFE, many potential losses will be avoided. The single most expensive component often lost during a severe event is the outdoor condenser. The reason is that the condenser is usually placed in a position that, while perhaps minimizing expense for the HVAC system, leaves it exposed to the wind and water forces that accompany a severe storm.

To minimize damage to the outdoor condenser, do the following:

- Mount it on the side of the building that will be least affected by flood velocity flow and waves.
- Mount it above the DFE.
- Secure it so that it cannot move, vibrate, or be blown off its support.
- Protect it from damage by airborne debris.

There are several ways to support an outdoor condenser with a connection to the floor framing. These include the following:

- cantilever floor framing (see Figures 13-32 and 13-33; this method requires careful detailing to prevent water penetration into the building floor and wall systems)
- pile-supported
- wood-brace-supported (see Figures 13-34 and 13-35)
- rooftop mount

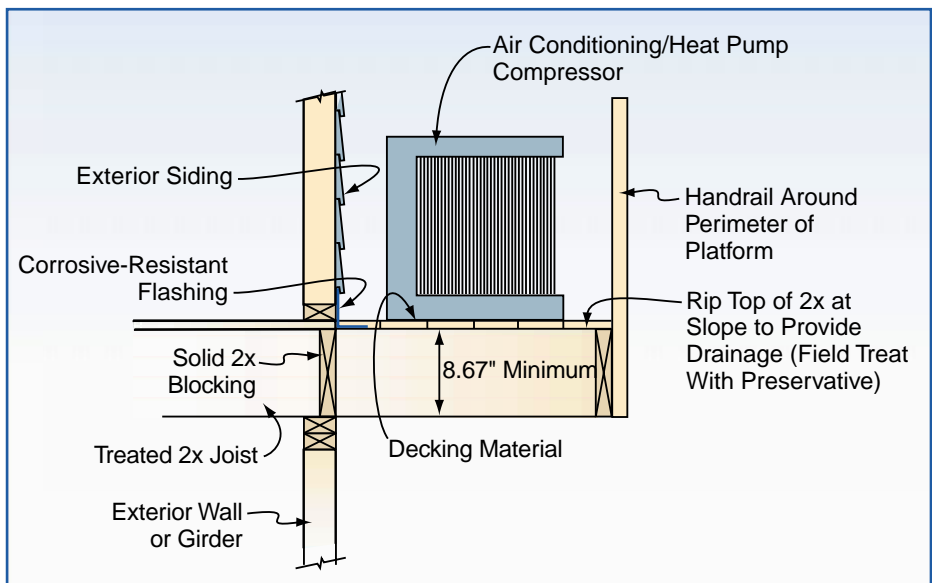
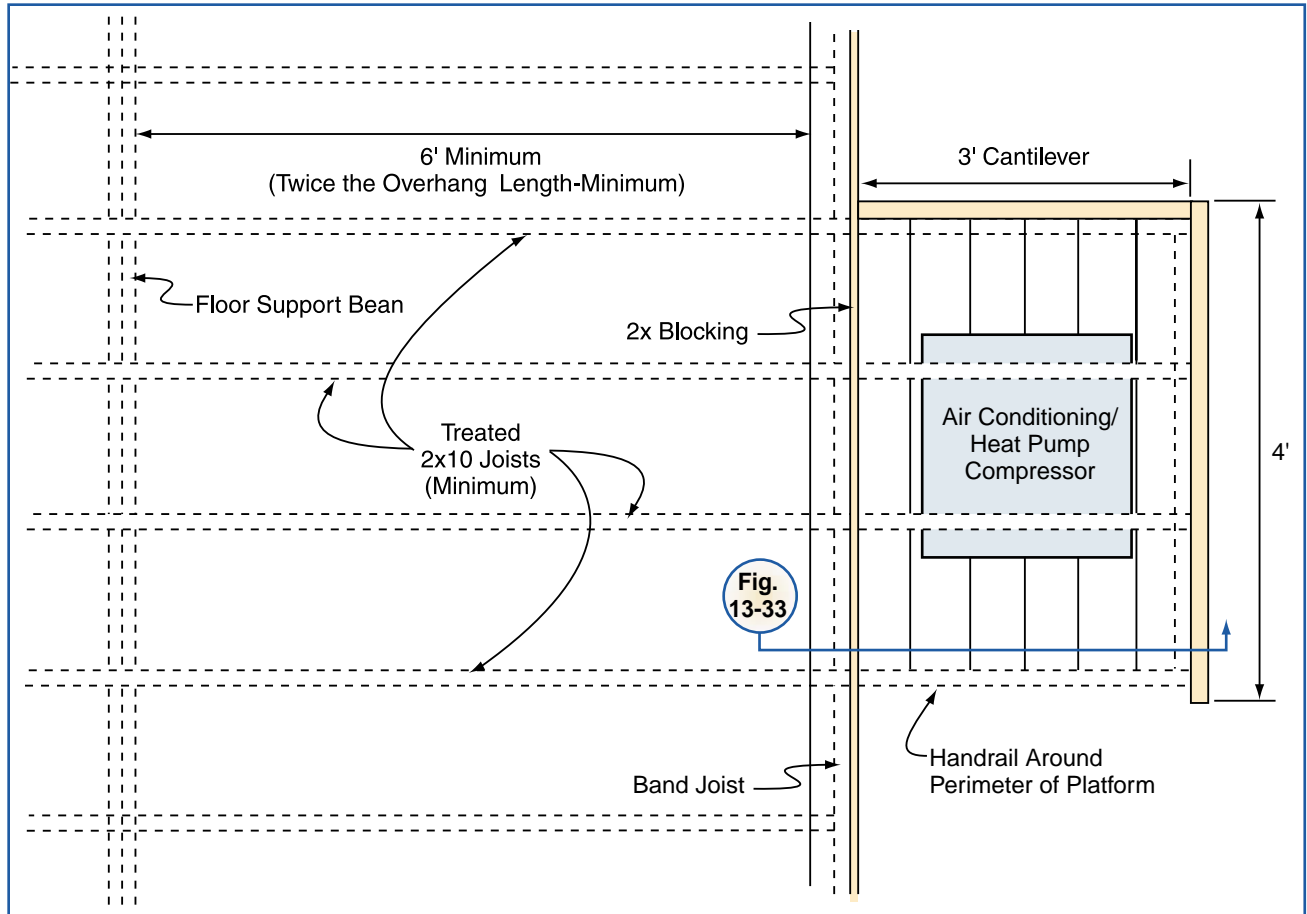


#### **COST CONSIDERATION**

HVAC equipment that is not elevated above the DFE will probably need to be repaired or replaced after a flood.

**Figure 13-32**

Cantilever floor framing for air-conditioning/heat pump compressor platform – plan view.

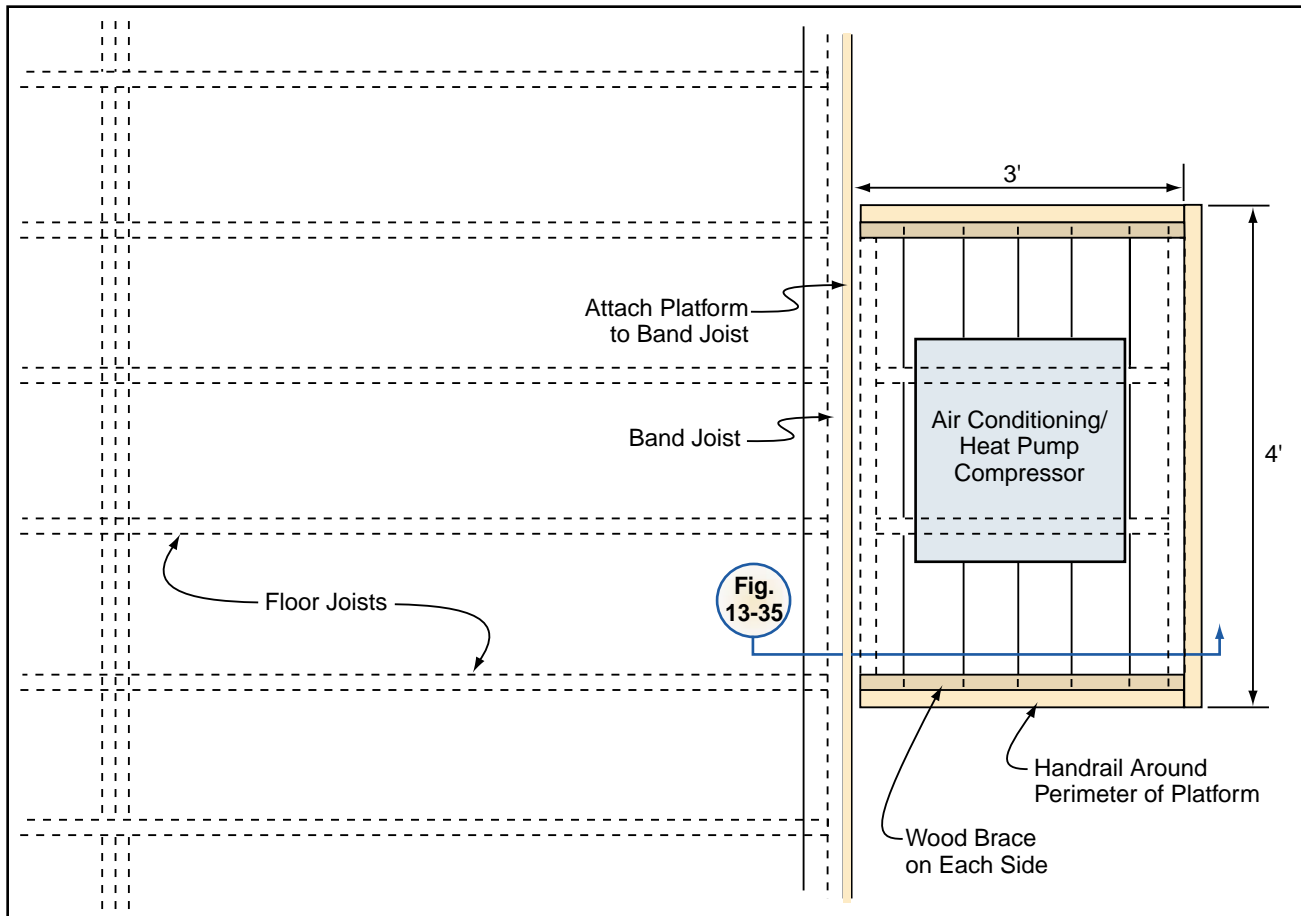


**Figure 13-33**

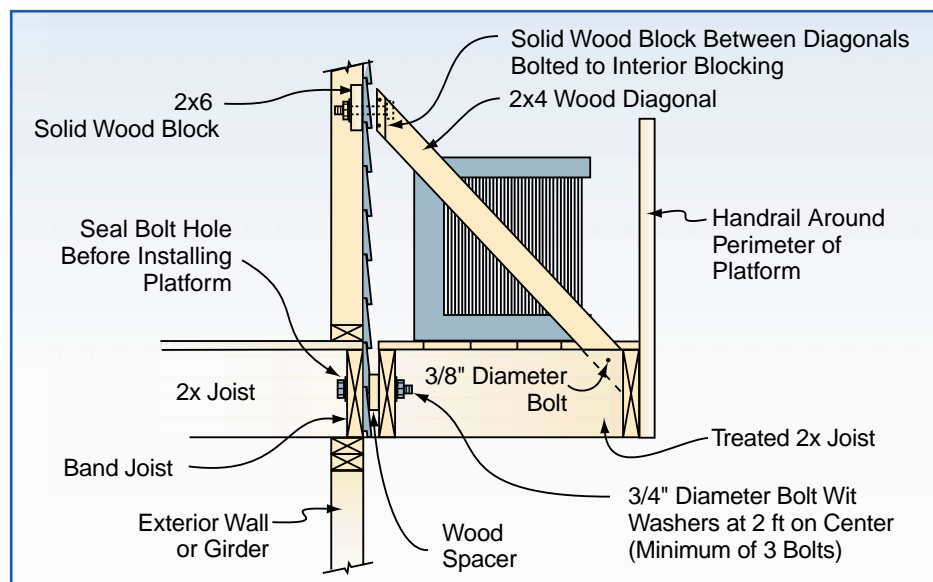
Cantilever floor framing for air-conditioning/heat pump compressor platform – elevation view.



**Figure 13-34**  
Wood-brace-supported air-conditioning/heat pump compressor platform – plan view.



**Figure 13-35**  
Wood-brace-supported air-conditioning/heat pump compressor platform – elevation view.



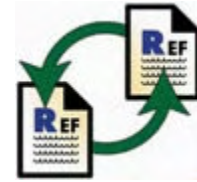
### 13.6.3 Electrical Systems

Installation of electrical components in coastal environments must consider the following:

- Any outlet, switch, or fixture below the DFE should be assumed to be at risk of damage and shorting out when inundated with water. For example, outlets installed below the DFE should be ground fault protected and equipped with moisture-resistant covers.
- Ferrous exterior fixtures and switches will corrode in the salt-laden environment.
- Any opening that wires are run through will leak water unless tightly sealed. Use drip loops to minimize water entry.
- Wires, conduits, and other system components should be installed on the landward side of piles or foundation elements, out of the path of flood forces.
- Many electrical companies will require that the electric meter be placed so that it can be read by utility company employees from the ground.
- Electrical components must not be attached to or penetrate breakaway walls.
- Electrical panels must be at or above the DFE.
- Electrical service below the DFE must be the minimum required for life safety.

### 13.6.4 Water and Wastewater Systems

The builder should install water and waste water risers and runs in such a way that flood and wind damage to them will be minimized. This means that risers should be installed behind piles or other foundation elements to protect them from flood forces and the impact of debris. Risers should not be installed on breakaway walls, because the lines will be damaged when the breakaway wall fails. Pipe runs that are parallel to the floor joists should be installed as high as possible between the joists. Pipe runs that are perpendicular to the floor joists should also be installed as high as possible. This may be accomplished by notching the joists and attaching ceiling sheathing. Such notching should be kept to a minimum, however, so that joists are not significantly weakened. An alternative is to install wood spacers on the bottom of the joists to provide sufficient room for pipe runs before installing a ceiling.



### CROSS-REFERENCE

Detailed information about the installation and protection of electrical system components is provided in *Protecting Building Utilities From Flood Damage – Principles and Practices for the Design and Construction of Flood Resistant Building Utility Systems*, FEMA 348 (FEMA 1999).



### WARNING

Utility system components must not be connected to breakaway walls under elevated buildings in coastal flood hazard areas. The resistance provided by electrical and plumbing lines and other utility system components can prevent the walls from breaking away as intended under flood forces.

**WARNING**

**Do not anchor tanks to break-away walls under elevated buildings.**

### 13.6.5 Tanks

Small tanks used for fuel, such as propane tanks, should be elevated above the DFE; if a tank is detached from its location during a severe flood event, it can become a windborne or waterborne missile. In addition to being elevated, small tanks also need to be strapped or otherwise secured to the building so that they will not be detached by high winds or a seismic event. Any strapping used should be corrosion-resistant. This technique can be altered to accommodate an exterior location. Builders should keep in mind that the strapping must resist forces from all four plan directions.

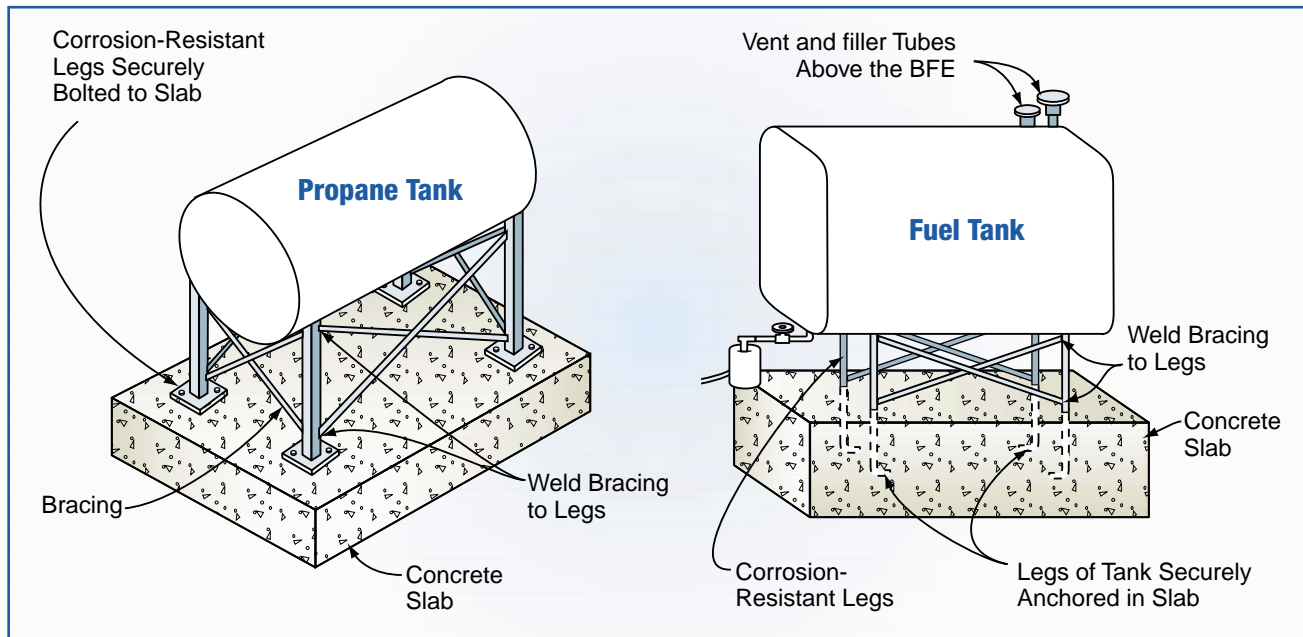
Larger tanks will normally be buried belowgrade or supported by and attached to a foundation. In a Special Flood Hazard Area, erosion and scour can expose the tank; the tank can fill with sediment/soil and salt water; or buoyancy forces on the tank can be sufficient to lift the tank out of the ground. Larger tanks may be used for septic tanks or for the storage of propane or fuel oil.

This manual recommends the following for minimizing damage to belowgrade tanks:

- Orient the tank so that scour is minimized. Do this by
  - orienting the tank with the narrowest dimension of the tank perpendicular to the flood flow,
  - orienting the tank so there is no angle of attack of the flood water, and
  - locating the tank so that flow diverted or channeled by nearby structures is not directed toward the tank.
- Secure the tank so that buoyancy forces will not lift the tank out of the ground. Do this by anchoring the tank to a concrete pad heavy enough to keep the tank in the ground.

Aboveground tanks can be anchored in at least two ways (see Figure 13-36). In addition, the tank must be located such that scour does not undermine the slab foundation, and the openings of fill lines and overflows must be above the DFE so that flood water will not enter the tank.

**Figure 13-36**  
Anchoring techniques for aboveground tanks.



## 13.7 References

American Concrete Institute. 1988. *Cold Weather Concreting*. ACI 306R-13. Detroit, MI.

American Concrete Institute. 1995. *Building Code Requirements for Structural Concrete*. ACI 318-95. Detroit, MI.

American Concrete Institute. 1996. *Placing Concrete by Pumping Methods*. 304.2R Detroit, MI.

American Institute of Timber Construction. 1984. *Typical Construction Details*. AITC 104-84. Englewood, CO.

American Institute of Timber Construction. 1986. *In-Service Inspection, Maintenance and Repair of Glued Laminated Timbers Subject to Decay Conditions*. AITC Technical Note 13.

American Society of Civil Engineers. 1982. *Evaluation, Maintenance and Upgrading of Wood Structures: A Guide and Commentary*. New York, NY.

American Society of Civil Engineers. 1998. *Minimum Design Loads for Buildings and Other Structures*. ASCE Standard ASCE 7-98.

American Society for Testing and Materials. 1988. *Standard Recommended Practices for Increasing Durability of Building Constructions Against Water-Induced Damage*. Standard E 241-77. Philadelphia, PA.

American Wood Preservers' Association. 1991. *Care of Pressure-Treated Wood Products*. AWPA Standard M4-91. Woodstock, MD.

American Wood Preservers' Association. 1994. *Standards*. Woodstock, MD.

Basham, K. 1995. "Cold Weather Concreting." *Journal of Light Construction*. January.

Bruce, Quarles, Shelly, et. al. 1997. *Wood Performance in Service, Workshop Notes*, Richmond, CA.

California Redwood Association. *Redwood File*. Novato, CA.

Chapdelaine, H. 1993. "Building Porches That Last." *Journal of Light Construction*. June.

*Coastal Living Magazine*. 1998. "Good Decisions: Decked Out." January.

Dost, W. 1986. *Performance of Wood Construction Materials, Kapalua Bay Villas*. WBRC report 35.04.20.

Dost, W. A. 1990. *Wood: Detailing for Performance*. Mill Valley, CA: GRDA Publications.

Federal Emergency Management Agency. 1999. *Protecting Building Utilities From Flood Damage – Principles and Practices for the Design and Construction of Flood Resistant Building Utility Systems*. First Edition. FEMA 348. November.

Forest Products Research Society. 1988. *Wood Protection Techniques and the Use of Treated Wood in Construction*. Madison, WI.

Forest Products Society. 1996. *Selection and Use of Preservative-Treated Wood*. Madison, WI.

Graham and Womack. 1972. *Wood-Metal Corrosion, An Annotated Survey*. Research Bulletin 21. Oregon State University College of Forestry, Forest Research Laboratory. Corvallis OR.

Hamilton, P. 1994. "On the Beach: Coastal Construction." *Journal of Light Construction*. April.

- Hamilton, P. 1997. "Installing a Steel Moment Frame." *Journal of Light Construction*. March.
- Highley, S. *Controlling Decay in Waterfront Structures*. Forest Products Laboratory. 1989.
- International Code Council. 2000a. *International Building Code*. Final Draft. Birmingham, AL. July.
- International Code Council. 2000b. *International Residential Code for One- and Two-Family Dwellings*. Birmingham, AL.
- McDonald, Falk, Williams and Winandy. 1996. *Wood Decks, Materials, Construction and Finishing*. Forest Products Society.
- Meyer, R. W.; Kellogg, R. M. 1982. *Structural Use of Wood in Adverse Environments*. New York: Van Nostrand Reinhold.
- Morrell, Helsing, Graham. *Marine Wood Maintenance Manual*. Research Bulletin 48. Oregon State University College of Forestry, Forest Research Laboratory. Corvallis, OR.
- National Evaluation Service, Inc. 1997. *Power-Driven Staples and Nails for Use in All Types of Building Construction*. National Evaluation Report NER-272. Reissued September 1.
- Nnaji, Soronnadi, et al. 1996. "Scour Impact of Coastal Swimming Pools on Beach Systems." *Journal of Coastal Research*. Winter. Ft. Lauderdale, FL.
- Schein, E. 1968. *The Influence of Design on Exposed Wood in Buildings in the Puget Sound Area*. USDA Pacific NW Forest and Range Experiment Station. Portland, OR.
- Simpson Strong-Tie Co., Inc. 1997. *Simpson Wood Construction Connectors*.
- State of Florida, Bureau of Beaches and Coastal Systems. 1998. *Beach/Dune Walkover Guidelines*. January.
- University of Florida Sea Grant Institute. 1983. *Beach Dune Walkover Structures*. December.
- U.S. Department of the Navy. 1982. *Foundation and Earth Structures Design*. Manual 7.2. Alexandria, VA. May.
- Yazdani, Nur, et al. 1997. "Conceptual Breakaway Swimming Pool Design for Coastal Areas." *Journal of Coastal Research*. Winter. Ft. Lauderdale, FL.